

motive

NEO-WiFi

Technical Manual



motive

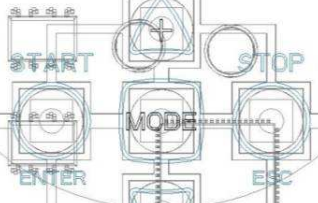

M16

M16

M20

M20

POWER MOTOR ALARM

READY

NEO-WiFi tutorial

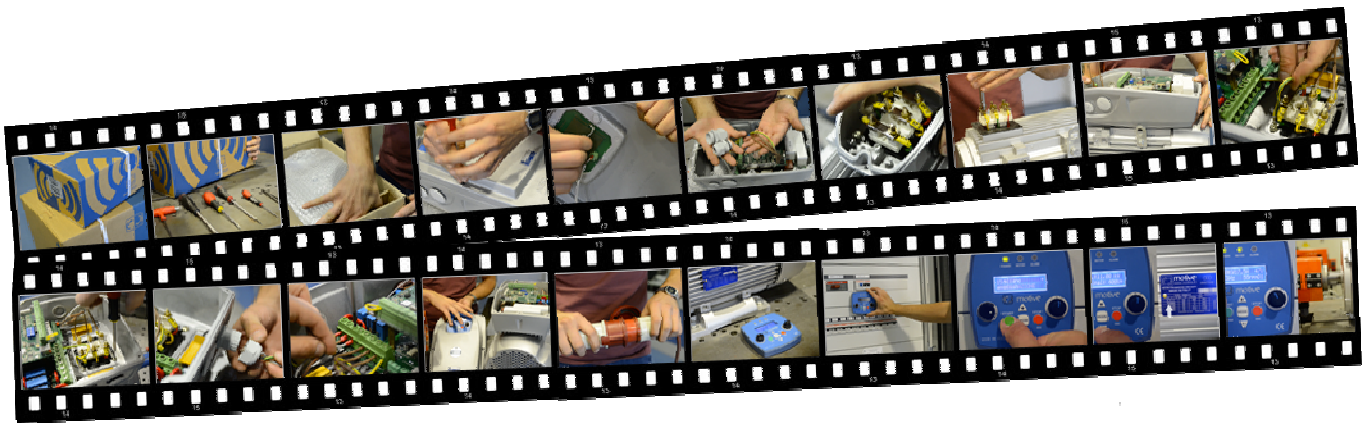

https://www.youtube.com/watch?v=hUXJ47P_Qxo&feature=youtu.be

CONTENTS:

1. INTRODUCTION
 - Examples
2. WORKING CONDITIONS
 - NEO-WiFi EMC = Secure operation
3. MOTORS THAT CAN BE CONNECTED
4. MECHANICAL ASSEMBLY
 - 4a. Dimensions
 - 4b. Motor mounting
 - 4b.1. Forced ventilation
 - 4b.2. Cooling of NEO-WiFi-11 + 11kW motor
 - 4b.3. Brake motors release lever
 - 4c. Wall mounting NEO-Wall (option)
 - 4d. Keypad
 - 4d.1. Keypad batteries
 - 4d.2. BLOCK – induction power charger for table or wall mounting
5. ELECTRICAL ASSEMBLY
 - 5a. Warnings
 - 5b. Electrical connection of NEO-WiFi
 - 5b.1. Protection and safety devices
 - 5b.1.1. Dimensioning of protection and safety devices
 - 5b.2. Connection to the motor
 - 5b.3. Diagrams
 - 5c. The 87Hz technique
 - 5d. Connection of the external devices
 - 5d.1. Examples
 - 5d.2. Bluetooth module mounting (optional code BLUE)
 - 5d.3. 3PH Power switch mounting (optional)
6. PROGRAMMING
 - 6a. First installation
 - 6a.1. Adjustment of the Keypad-Inverter communication
 - 6b. Keypad buttons
 - 6c. Keypad leds
 - 6d. Functions menu
 - 6e. Advanced functions menu
 - 6f. Use
 - 6g. Alarms
 - Compatibility table chart SW versions between Inverter and Keypad
 - 6h. MODBUS
7. MOTIVE MOTOR MANAGER
 - 7a. Download and Installation
 - 7b. USB-RS485 Converter connection settings
 - 7c. Main functions
 - 7d. Reading and writing parameters
 - Modbus Variables table chart
8. WARNINGS AND RISKS
 - DECLARATION OF CONFORMITY



1. INTRODUCTION

The purpose of an integrated motor-inverter is to save time and reduce costs in supplementary material (wires and racks mainly), study, installation, programming and testing of the motor + inverter system, as well as the dangers due to errors associated with these operations. However, before NEO-WiFi, there were factors that limited the availability of motor-inverters: the degree of protection that was needed (motors can be installed out in the open, while inverters could not) and the fact that the motor-inverter, and therefore its keypad, remain removed from whoever is commanding it (imagine, for example, a ventilator that is on a roof). Motive has solved both problems with NEO-WiFi, patented, easy to use, IP65 (III. 2), with removable control panel, removable wireless, powered by induction (III. 1) when placed in its housing on the motor or by lithium rechargeable batteries (III.14). While possessing the most advanced features of the other inverters, NEO-WiFi, thanks to its innovative solutions, is designed as a competitive and user-friendly turnkey integrated system, with all parts, motor, inverter and control designed for outdoor use, and with standard remote control. The manufacturers of



pumps, fans, and other machines can thus offer a finished “plug-in” product, without delegating risky and costly installations to their customers. Their customers need only to insert the plug, wherever it is installed, and decide if they want to bring the keypad with them.

This manual is intended to provide all the necessary information for connecting, programming and using **NEO-WiFi** Three-phase inverter for industrial use. NEO-WiFi is specifically designed for operating industrial motors, with the goal of guaranteeing perfect speed control, significant energy savings and a greater use of inverters.

Examples

Adjusting the flow/pressure/force of a pump, a hydraulic power unit, an oil-hydraulic actuator, a compressor, an extraction fan, a ventilator, etc is normally done through shutters or valves. If we have a choke device of this kind, it means we have chosen not to use a variable speed drive (inverter). In this case, the disadvantages are numerous: inability to program ramping up or stopping; nor to synchronize multiple devices; fewer opportunities for interaction with other machines and controls (such as a pressure transducer), less access to controls, more noise, greater peak currents; shorter life of the motor and of the mechanical parts of the system; and above all the absence of energy savings. It is like controlling the speed of a car just by using the brake.

An inverter also simplifies the installation because a system with direct or star-delta type starting often involves the use of suitably oversized power contactors to counter the high electric arcing caused by the overcurrent normally associated with these starting systems. In addition, protection systems for the motor via circuit breakers should always be provided. So: shutter/valve + cabinet + knife switch + motor control relay + motor overload protection automatic switch could be saved with a variable speed drive. Let's add that in certain applications, just the cost of the choke (think for example of the proportional valve of a hydraulic power unit) exceeds that of an inverter.

So why not just use inverters? Essentially for the ease of assembly (assumed) with respect to an electronic device to be wired up and programmed, the reduced size, the degree of protection from dust and liquids and the ease of use, the difficulty of integrating in the system the inverter with its cabinet, the accessibility of the controls. Sometimes also the cost of the inverter can be considerable, especially when it is added to that of a cabinet and cables.

With NEO-WiFi these reasons are no longer valid. There remain only the advantages of the inverter. In fact:

- NEO-WiFi is a motor-inverter and as such cancels the need for cables and cabinets, the study, the installation, the wiring, and the testing of the motor+inverter system, as well as the risks associated with possible errors.
- Not requiring cables and cabinets, and being an integral part of the motor, it does not take up space
- Programming is easier than using the TV remote control
- The keypad of the NEO-WiFi is removable, can operate remotely over wireless and can be placed up to 20 meters away. No wiring, no cables. It does not need wiring because it is supplied by induction when placed in its housing on the motor or in the "BLOCK" device, or fed by rechargeable lithium batteries. Imagine for instance the advantage of installing a ceiling fan with this drive and controlling it from wherever you want without any installation cost
- Even a child knows how to use a device with a red button, a green one, a left-zero-right switch and a control knob
- NEO-WiFi is IP65. Its keypad is IP67

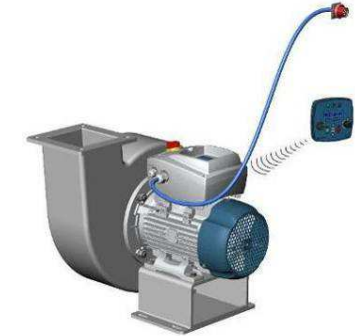
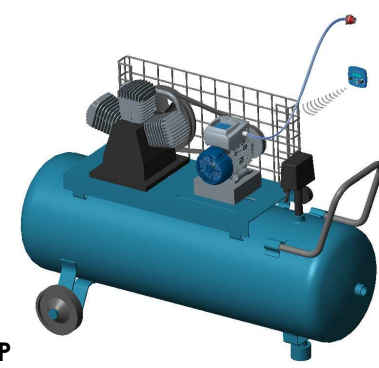
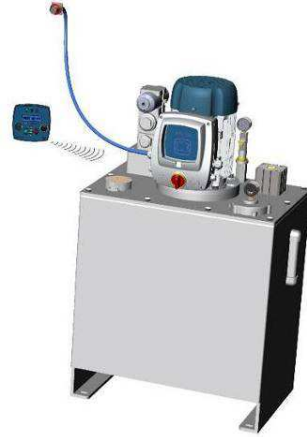
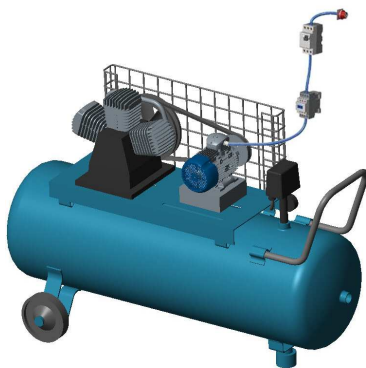

NEO-OLEO

NEO-OLEO

NEO-COMP

NEO-VENT

2. WORKING CONDITIONS

III. 2



Feature	Symbol	U.o.M.	NEO-WiFi-3kW	NEO-WiFi-4kW	NEO-WiFi-5.5kW	NEO-WiFi-11kW	NEO-WiFi-22kW	
Inverter protection degree*	IP		IP65					
Inverter supply voltage	V_{1n}	V	3x 200-460					
Inverter supply frequency	f_{1n}	Hz	50-60					
Maximum output voltage of the inverter	V_2	V	= $V_{1n} \cdot 5\%$					
Inverter output frequency	f_2	Hz	200% f_{1n} [f_2 100Hz if f_{1n} 50Hz]					
Rated input current to the inverter	I_{1n}	A	7.5	11	15	23	47	
Rated output current from the inverter (to the motor)	I_{2n}	A	7.0	10	14	22	45	
Maximum continuous current output from the inverter	I_2	A	$I_{2n} + 5\%$					
Maximum Starting torque / Rated torque ratio	C_s/C_n	Nm	150% 3kW	150% 4kW	150% 5.5kW	160% 11kW	150% 22kW	
Maximum Starting current (kept for 3 seconds)	I_{2max}	A	10.5	15	21	35	67	
Storage temperature	T_{stock}	°C	-20 ÷ +60					
Environmental operating temperature	T_{amb}	°C	-20 ÷ +40 (-20 only with inverter powered and pre-heating function active)					
Maximum relative humidity		% (40°C)	50					
Maximum WiFi keypad-inverter communication distance out in the open		mt	20					
Power losses (% motor speed ; % load torque)	(50 ; 25)	%	4.1 (IE2)	3.8 (IE2)	3.4 (IE2)	2.5 (IE2)	2.0 (IE2)	
	(50 ; 50)	%	4.6 (IE2)	4.2 (IE2)	3.8 (IE2)	2.9 (IE2)	2.4 (IE2)	
	(50 ; 100)	%	5.6 (IE2)	5.3 (IE2)	4.9 (IE2)	4.2 (IE2)	3.8 (IE2)	
	(90 ; 50)	%	4.9 (IE2)	4.6 (IE2)	4.2 (IE2)	3.2 (IE2)	2.8 (IE2)	
	(90 ; 100)	%	6.7 (IE2)	6.4 (IE2)	6.0 (IE2)	5.4 (IE2)	5.0 (IE2)	
Stand-by losses		W	4	4	4	6	10	

Tab. 1: operating conditions

Further characteristics	NEO-WiFi-3kW	NEO-WiFi-4kW	NEO-WiFi-5.5kW	NEO-WiFi-11kW	NEO-WiFi-22kW
Motor control	V/F	V/F	V/F	vectorial	vectorial
Synchronous motors control	NO	NO	NO	optional	optional
Programmer with built-in clock and battery (to make it possible to plan starts and stops)	NO	NO	NO	YES	YES
EMC for INDUSTRIAL ENVIRONMENT (ref. EN 50081-2, para 5)	YES	YES	YES	YES Class A – Cat C2	YES Class A – Cat C2
EMC for DOMESTIC, COMMERCIAL AND LIGHT INDUSTRIAL ENVIRONMENT (ref. EN 50081-1, para 5)	YES Class A – Cat C1	YES Class A – Cat C1	YES Class A – Cat C1	optional	optional
3PH Power Switch	optional cod.INTEM3X32A	optional cod.INTEM3X32A	optional cod.INTEM3X32A	optional cod.INTEM3X32A	optional cod.INTEM3X63A
 Communication Protocol (from July 2014)	MODBUS RS485	MODBUS RS485	MODBUS RS485	MODBUS RS485	MODBUS RS485
Internal braking resistances	YES	YES	YES	YES	YES

For different environmental conditions contact our Support Service

*The IP65 degree refers to both the inverter case and to the removable keypad, whether it is placed in the inverter case or whether inverter and keypad are distant from each other. This is possible thanks to:

- adoption of an induction powered system (III. 1) instead of "male-female" connectors,
- shapes of the cases of the 2 items
- special sealing gaskets on the keypad (III. 3) and on the inverter case (III. 4)



III. 3



III. 4

NEO-WiFi EMC = Secure operation



Have you ever had a sporadic and inexplicable malfunction of electrical/ electronic devices? For example, an automatic gate, a computer, a PLC, a circuit breaker ... If you didn't find the fault, it was probably due to the electromagnetic compatibility of the device (not sufficiently immune to electrical/electromagnetic interference received from the power line or radiated in the air) or to that of other equipment that showed no malfunction but was disturbing your device. Electromagnetic compatibility is a requirement prescribed by law and by the need to guarantee the operation of all electrical/electronic equipment, on the basis of which it must in practice:

- limit below precise thresholds emissions of electrical and electromagnetic interference which can affect the operation of other devices, whether the interference is radiated through the air or conducted in the power line or in the earth return circuits;
- be immune to a series of conducted and radiated interference that may be present in the environment in which it is intended to operate.

It is important therefore not only to protect the operation of the inverter (variable speed drive), but also to protect all the other devices from it. Electromagnetic compatibility is therefore the result of coexistence without reciprocal interference of devices in the same environment.

In an industrial environment, the immunity level must be higher compared to the others, but on the other hand, in a residential, commercial or light industrial environment, it is necessary to limit potential interference emissions more than in the industrial environment. So the regulations define these two environments:

DOMESTIC, COMMERCIAL AND LIGHT INDUSTRIAL ENVIRONMENT (ref. EN 50081-1, para 5)

This concerns residential, commercial and light industrial locations, both internal and external.

Locations with a power supply from 50 to 1000V provided direct from the public network are considered residential, commercial or light industrial locations.



INDUSTRIAL ENVIRONMENT (ref. EN 50081-2, para 5)

Industrial environments are characterized by the existence of one or more of the following conditions:

- presence of industrial, scientific or medical equipment
- inductive and capacitive loads are frequently switched
- currents and associated magnetic fields are high



The part of the first definition that we have underlined contradicts a recurrent belief: in fact, not every location that is often considered an "industrial environment" is only that for the EMC regulations. Indeed, the vast majority of companies also fall within the definition of light industry and their facilities and equipment must therefore satisfy the legal requirements of both environments.

Nevertheless, most of the three-phase inverters circulating on the market are declared in conformity with the regulations which relate only to the industrial environment and, at times, they place limitations even on this.

Having said this, and wanting to talk about the EMC advantages of NEO-WiFi, we cite the two main ones:

1. **maximum distance between inverter and motor**

In a normal motor/inverter installation it is necessary to minimize the parasitic capacitance of the system and for this (but not with NEO-WiFi), the cables connecting motor and inverter should be short and of shielded type, or unshielded but inserted in a duct or metal tube connected to earth. This also because the cables connecting motor and inverter also radiate radio waves. It is not uncommon for inverter manufacturers, in their declaration of conformity, to specify for the sake of correctness the maximum length of the cable connecting motor and inverter and this statement may be considered valid.

With an inverter motor this problem does not exist, because motor and inverter are a single unit. If, however, we were unable to control the inverter motor in its position (under a conveyor belt, in the narrow space in which a hydraulic control unit was installed, on an industrial fan attached to a ceiling, etc.), with a normal inverter motor we would still have to have a control device connected via cable to the inverter. This problem does not exist with NEO-WiFi, whose detachable keypad is connected to the inverter via authorized and tested radio frequencies.

2. **the installation of additional anti-interference filters**

To make a compatible inverter, the manufacturer will have to allow for additional costs, such as the insertion of components, shielding and filters. To offer a price apparently more attractive, a frequent trick is to not incorporate in the inverter everything you need and to resolve the problem by requiring you in the instruction manual to buy anti-interference filters separately and install them. A careless buyer may then fool themselves that they have saved, only to find out later, on reading the manual, that if he/she wants to comply with applicable laws and avoid problems operating the inverter or other devices in the same environment, he/she will have to incur additional costs for materials and installation.

Another recurrent story is installing inverters suitable only for industrial environments, even if the company has power supplied directly from the mains, putting at risk the operation of other devices. This leaves the problem to the end user to understand why an automatic gate, a computer, a PLC, a protective circuit breaker or other electronic devices in the same environment will begin to have problems of malfunction which will not be confirmed and resolved by the suppliers of the inverter.

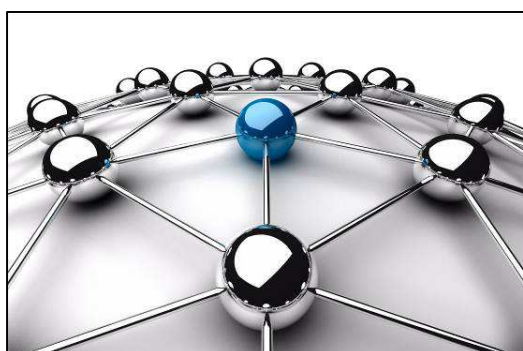

NEO-WiFi was designed as a plug-and-play inverter motor, to avoid the costs of additional materials and labour to the buyer. It had to take into account, viewing the situation seriously, the fact of having been designed for its intended environment, without the need for additional material and installation costs.

Very unusually, therefore, in the NEO-WiFi-3 project, Motive has been careful to make it compatible not only with the industrial environment, with high immunity, but also to keep its emissions below the most restrictive thresholds prescribed for the home, commercial and light industrial environment, without the need to install additional external filters.

NEO-WiFi-11kW, however, because of its greater power, is the standard suitable for installation in industrial environments but requires the installation of an optional

external anti-interference filter to make it suitable for the domestic, commercial and light industrial environment too.

3. MOTORS THAT CAN BE CONNECTED

Tab. RP: Power range of motors that can be connected*

Motor kW	0,13	0,18	0,25	0,37	0,55	0,75	1,1	1,5	1,9	2,2	3	4	5,5	7,5	9,2	11	15	18,5	22
NEO-WiFi-3	■	■	■	■	■	■	■	■	■	■	SV								
NEO-WiFi-4									■	■	■	■							
NEO-WiFi-5.5										■	■	■	■						
NEO-WiFi-11											■	■	■	■	SV	SV+F			
NEO-WiFi-22																■	■	■	■

SV= applicable power only with forced ventilation (chap. 4a)



F= needed also 2 internal fans (chap. 4a)

* Inverters should not be divided by power kW (they are classified by power only for practicality and by habit), but by steady current output A. Current A is inversely proportional to voltage V.



The power that can be applied is dependent not only on the electronic characteristics of NEO-WiFi, but also on the dissipative capacity of its case. It is therefore not allowable to use the electronic board in cases that are different from the original one by removing the electronic board and mounting it in another case. This transferral would also compromise its electrical insulation and safety of the device with resulting inapplicability of the warranty

Tab. RD: Size range of IEC motors that can be connected

Motor IEC Type	63	71	80	90S	90L	100	112	132S	132M	160	180	200
NEO-WiFi-3	X	X	X	X			*X	*X	*X			
NEO-WiFi-4				X	X	X				X		
NEO-WiFi-5.5				X	X	X				X		
NEO-WiFi-11				X	X	X				X		
NEO-WiFi-22												X

*. after removing the plastic knockout as shown in chap.4
 X. required mechanical adapter, chapter 4

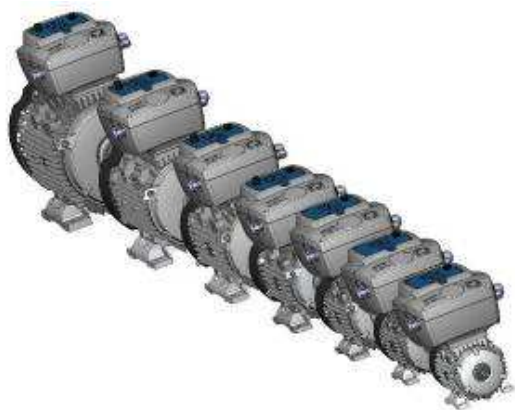

Why connect motors size 112 and 132 to a NEO-WiFi-3kW or motors size 160 to a NEO-WiFi-11kW? Because motors with more than 4 poles can be of a greater size (for example, 112M-6 2.2kW, 132S-6 3kW, 132S-8 2.2 kW and 132M-8 3kW).

It is important that the motor is suitable to be powered by Variable Speed Drive VSD. A fundamental requirement is that it has reinforced insulation between the phase windings. Others, are the limited current absorption and low temperature rise, since the current is the limit of an inverter and the motor temperature will heat the inverter. The Delphi series of motive motors, as a standard feature, can be powered by an inverter and are designed to fit with motive VSD.

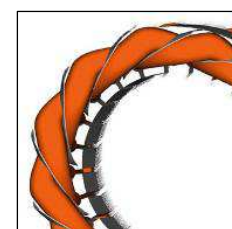

4. MECHANICAL ASSEMBLY

4a. Dimensions

NEO-WiFi-3 and keypad



NEO-WiFi-4 - NEO-WiFi-5.5 - NEO-WiFi-11

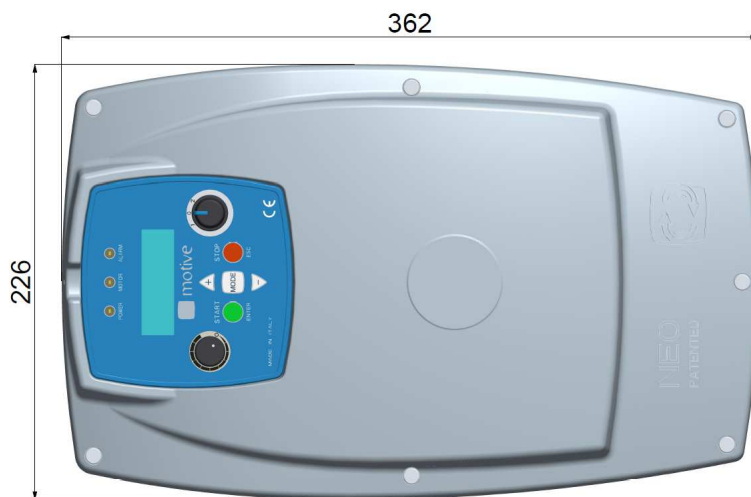

NEO-WiFi-22

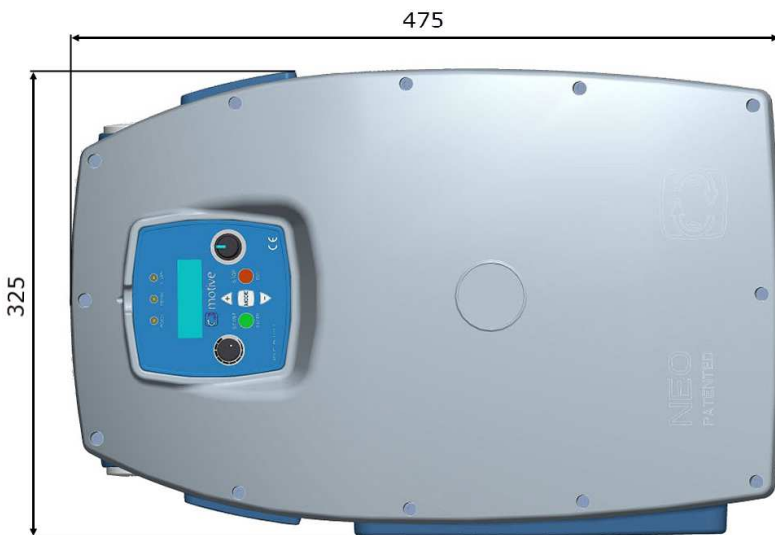
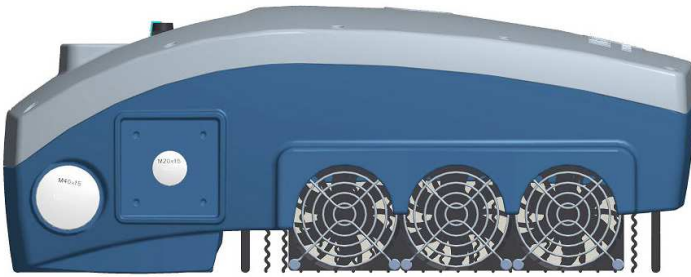

Dimensions NEO-WiFi + motor

Motor IEC Type	NEO-WiFi-3			NEO-WiFi-4 NEO-WiFi-5.5 NEO-WiFi-11			NEO-WiFi-22		
	AD1	AD2	L	AD1	AD2	L	AD1	AD2	L
63	188	202	264						
71	195	208	278						
80	211	224	288						
90S	215	228	=	242		431			
90L	196	209	=	242		431			
100L	210	223	=	251		438			
112	233	246	=	261		447			
132S	252	265	=	274		475			
132M	252	265	=	274		=			
160M				342		=	335		640
160L							335		=
180M							350		=
180L							350		=

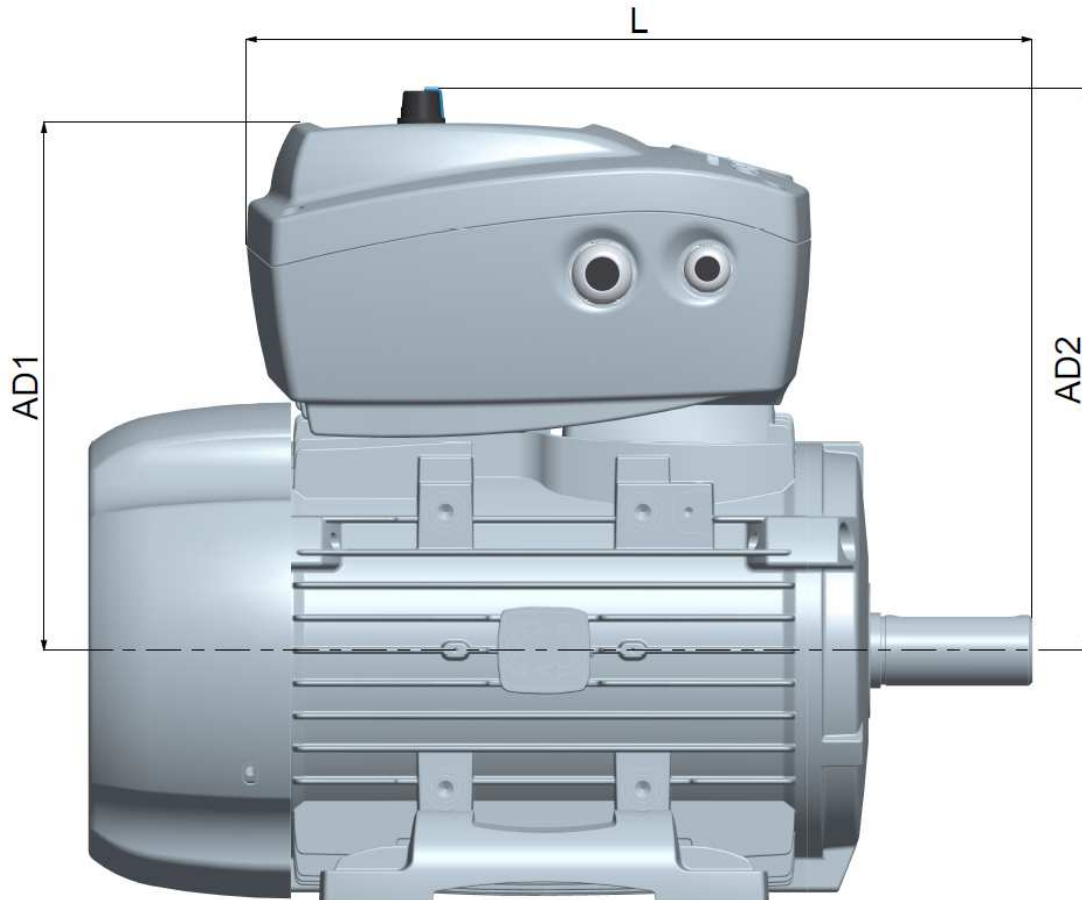

4b. Motor mounting

The mechanical fastening with slots (Ill. 5) allows the NEO-WiFi case to be fixed onto a wide range of Delphi series motive motors from size 71 to size 160 (Table. RD)

Ill.5

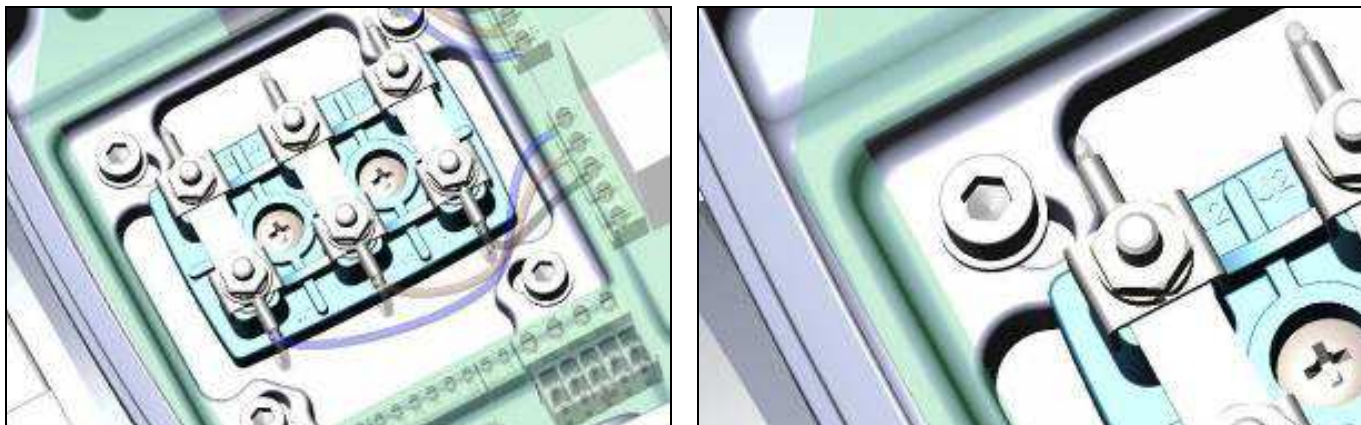

The plastic knockouts allow the NEO-WiFi-3kW to broaden its field of use to engines with greater sizes (Table RD), as shown in the following image.



Plastic knockout removal procedure

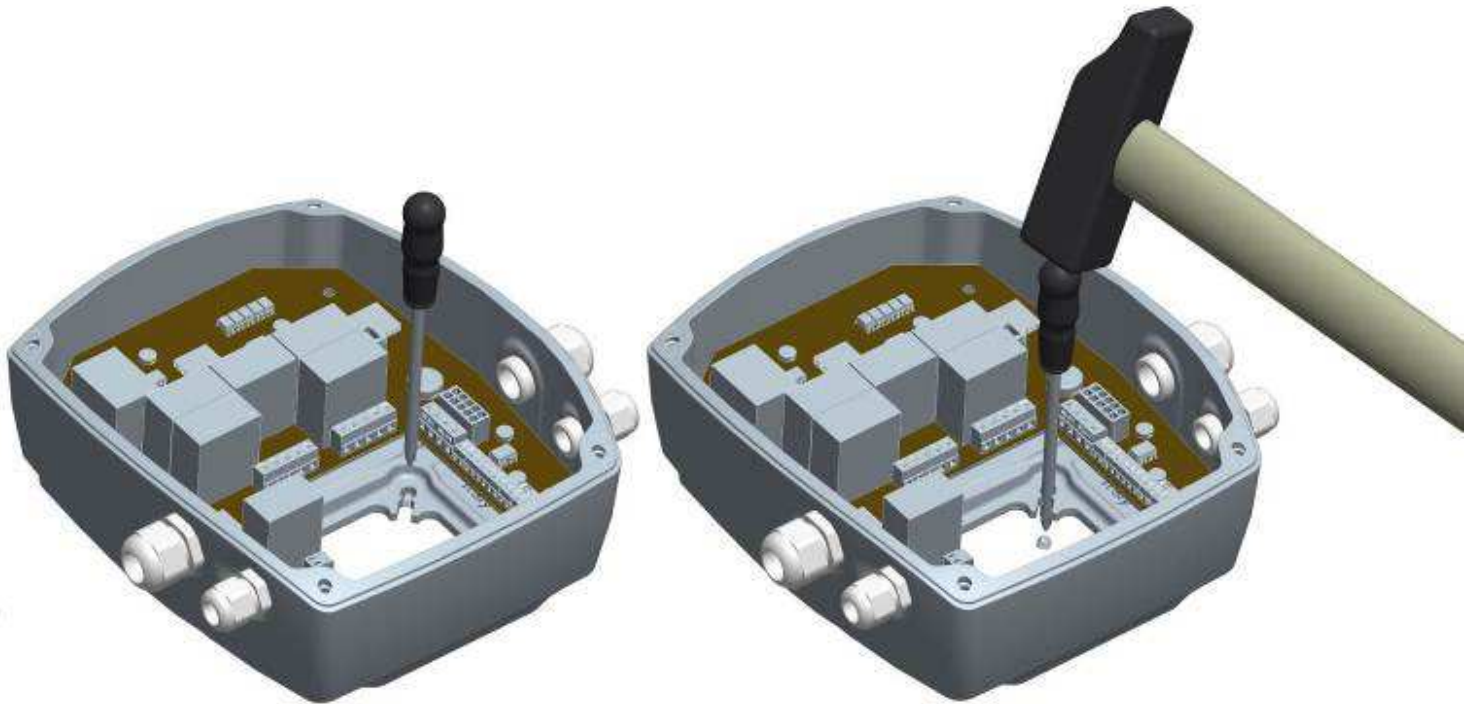

Be careful not to disperse metal or wire ends inside the housing of the inverter, that can create dangerous short-circuits.



For the connection between NEO-WiFi-3kw and the motors marked with X in the “Tab. RD”, specific mechanical adapters are needed. See the following images.

NEO-WiFi-3

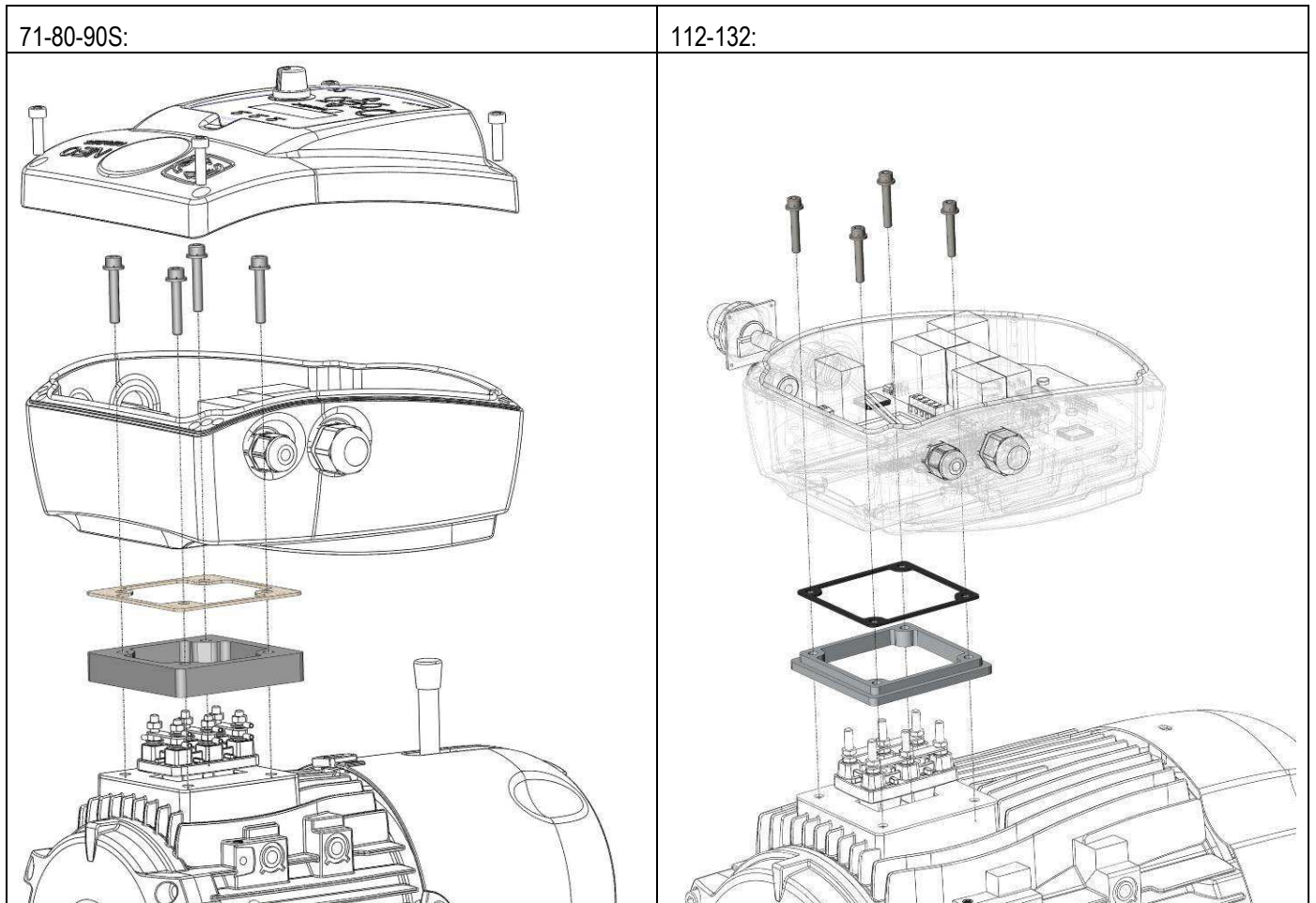

NEO-WiFi-4 - NEO-WiFi-5.5 - NEO-WiFi-11

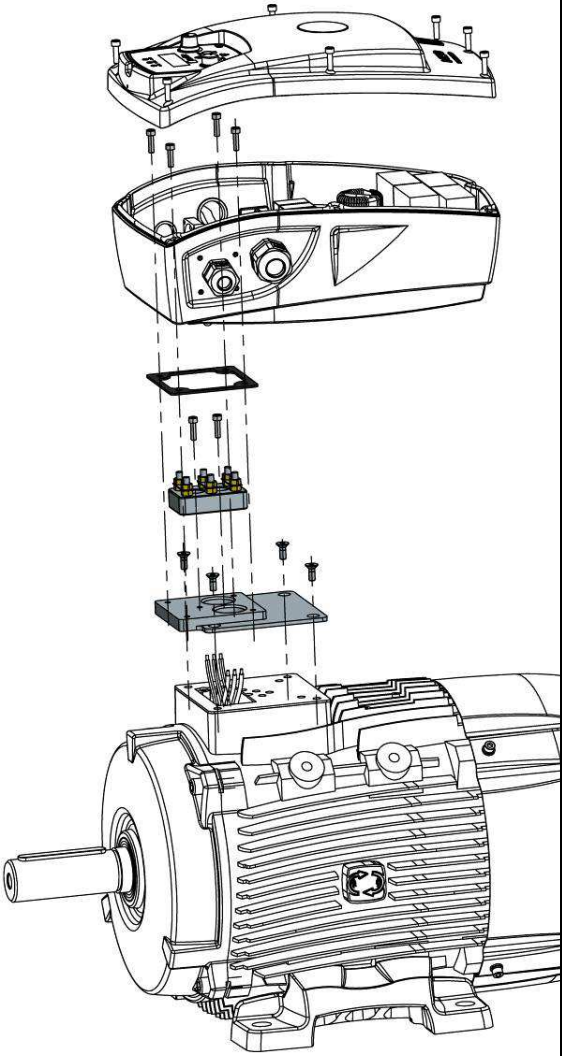
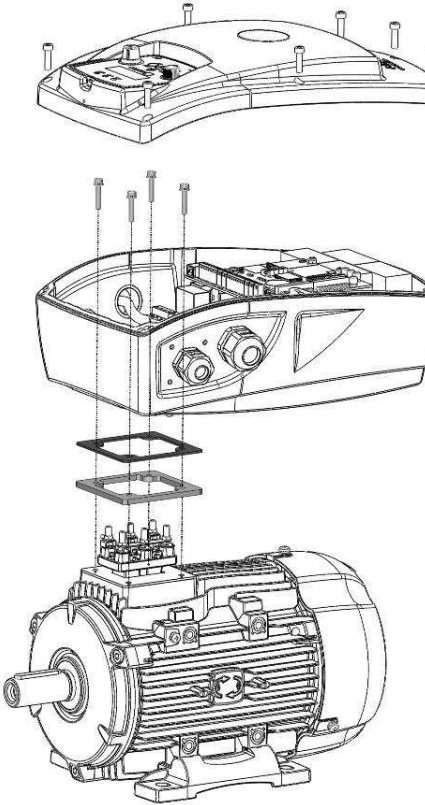
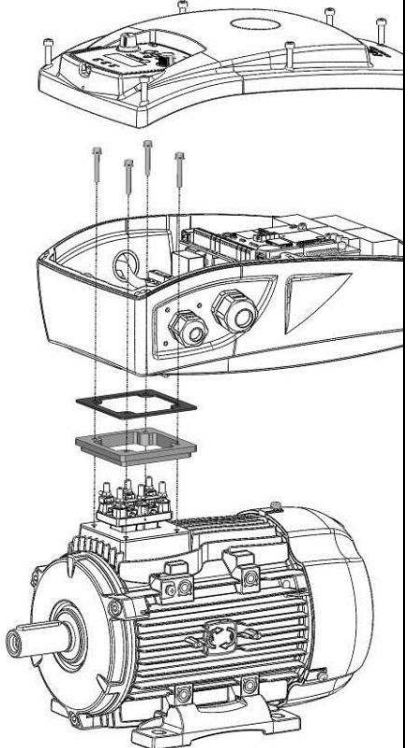
160M*	100L	90S/90L
		

* NEO-WiFi-4 - NEO-WiFi-5.5 - NEO-WiFi-11 + motor IEC 160M

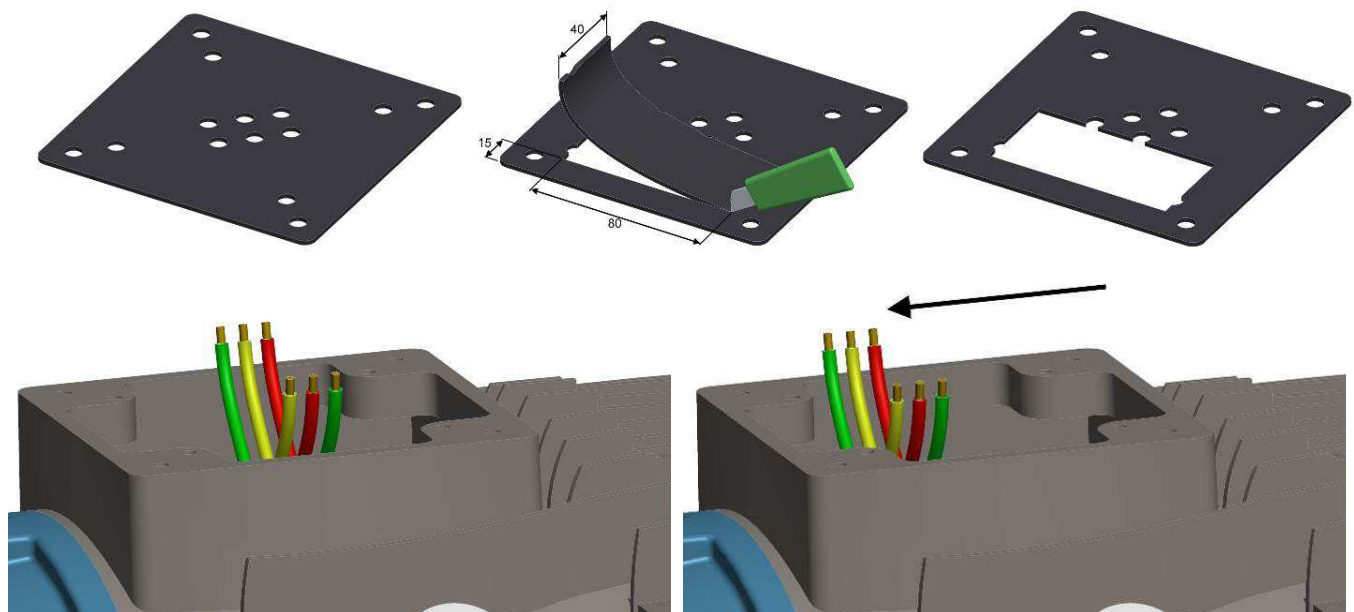
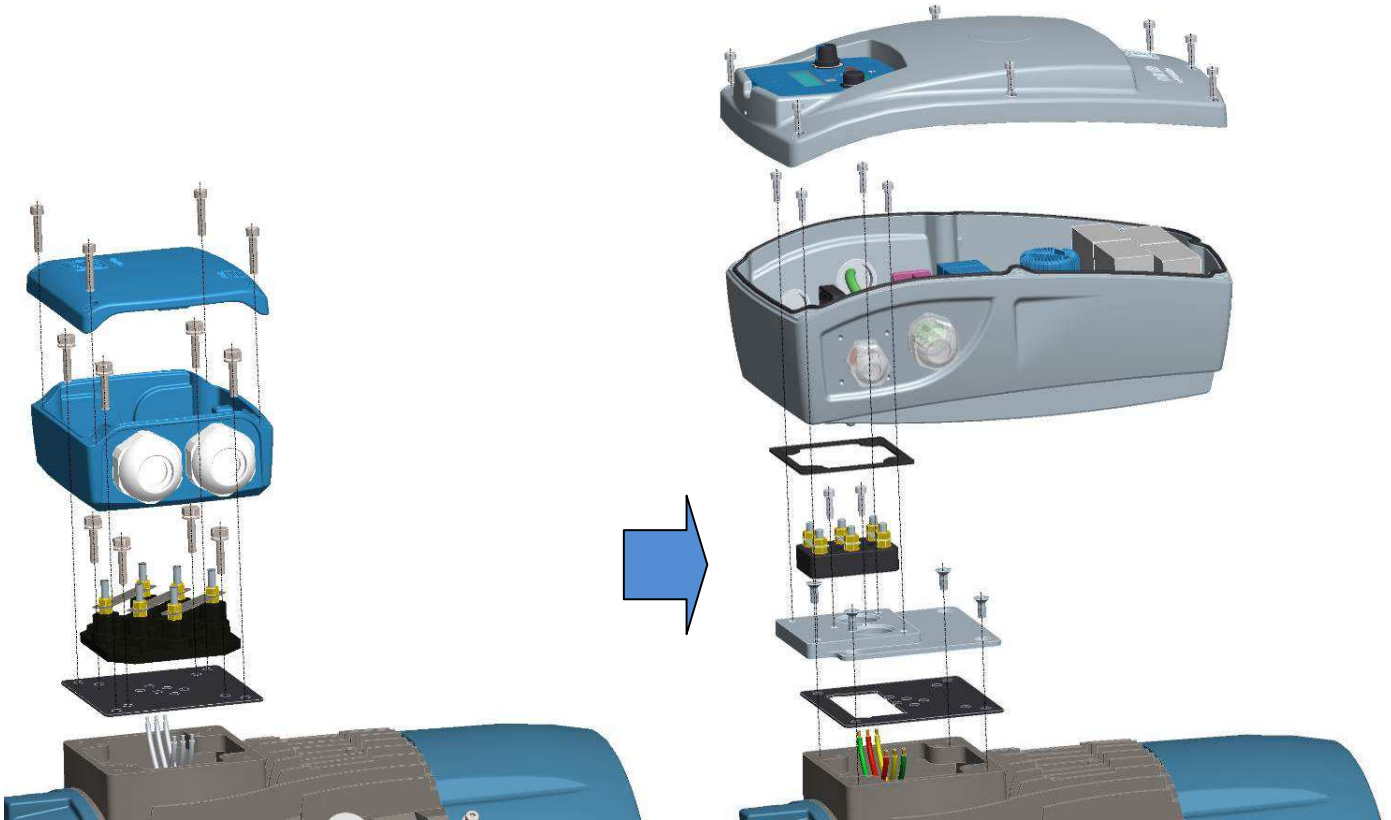

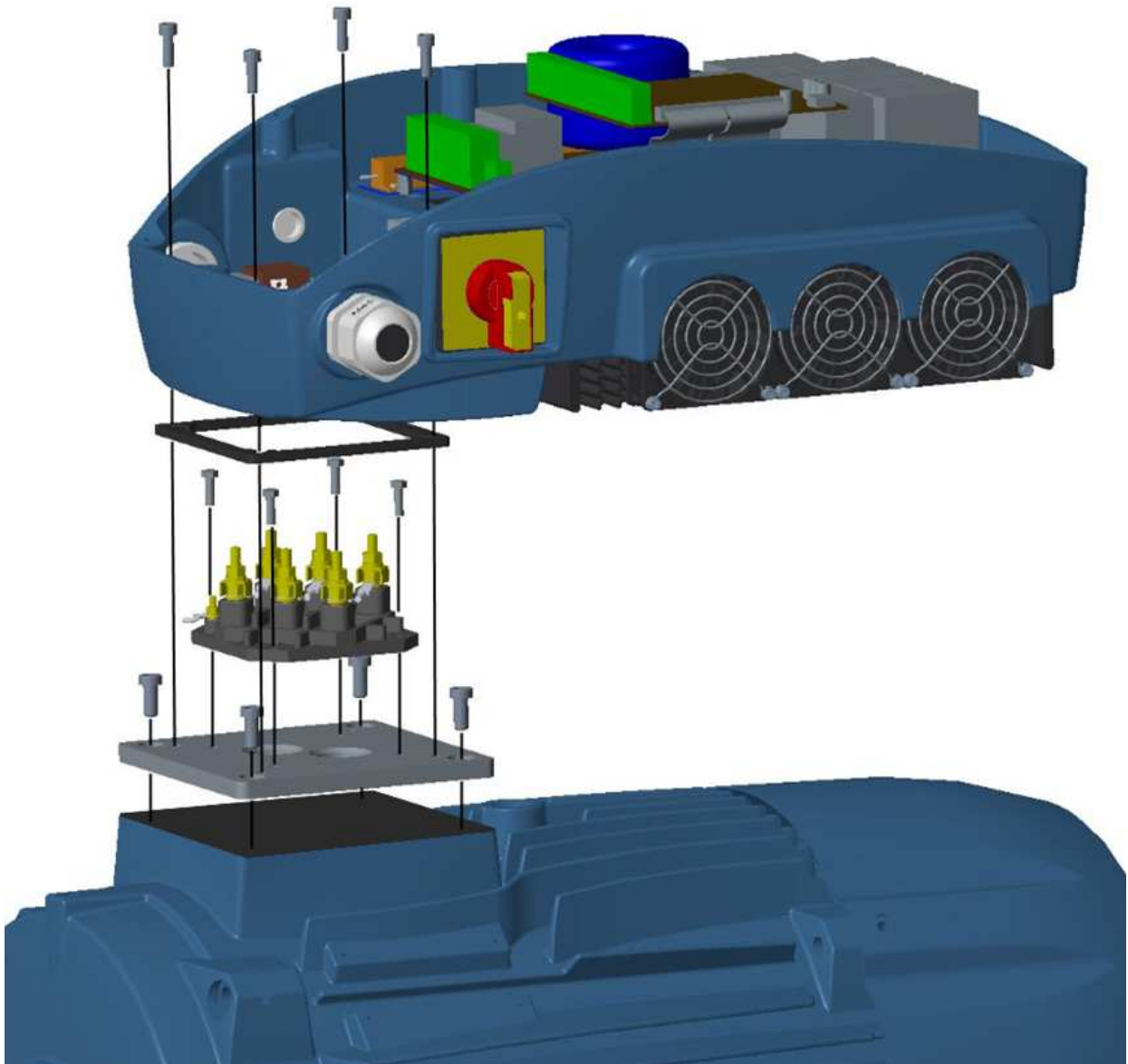

Do not lift or transport the motor connected to the inverter by gripping the inverter box.

4b.1. Forced ventilation

Do not lift or carry the motor connected to the inverter by holding the housing of the inverter.

If the inverter is used at frequencies lower than 50Hz, it becomes necessary to use motors with forced ventilation:



In some motor sizes (e.g. IEC80) there may be mechanical interference between the terminal box cover of the forced ventilation and the NEO-WiFi case. In these cases the forced ventilation can be turned 90 as shown below:

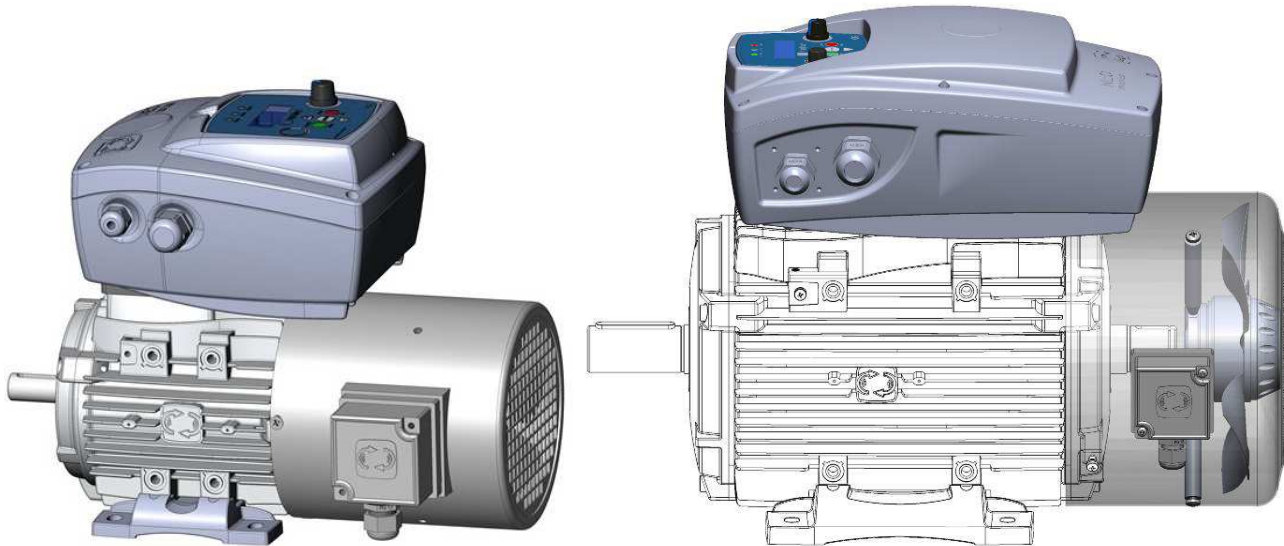

Motor IEC	71	80	90S	90L	100	112	132S	132M	160M	160L	180M	180L	200
NEO-WiFi-3	↔	↔	↔	↑	↑	↑	↑	↑					
NEO-WiFi-4			↔	↔	↔	↔	↔	↑	↑	↑			
NEO-WiFi-5.5			↔	↔	↔	↔	↔	↑	↑	↑			
NEO-WiFi-11			↔	↔	↔	↔	↔	↑	↑	↑			
NEO-WiFi-22									↔	↔	↔	↑	↑

4b.2. Cooling of NEO-WiFi-11 + 11kW motor



NEO-WiFi-11 with motor 11kW = needed also 2 internal fans (cod. NWF11FANKIT)

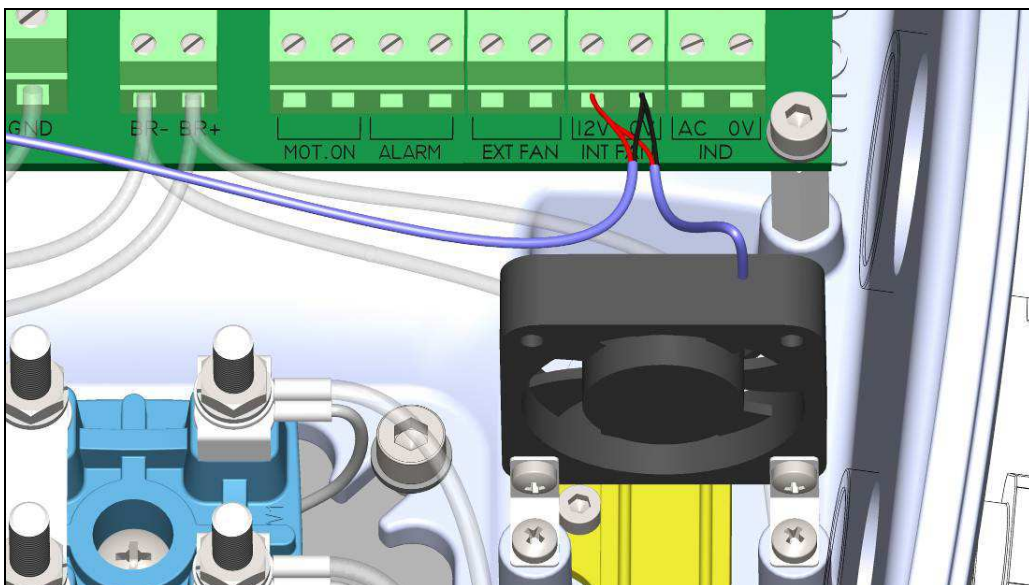
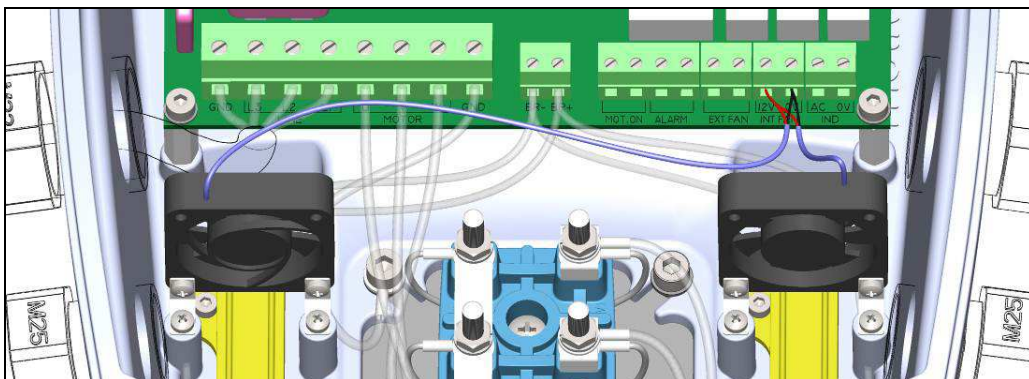
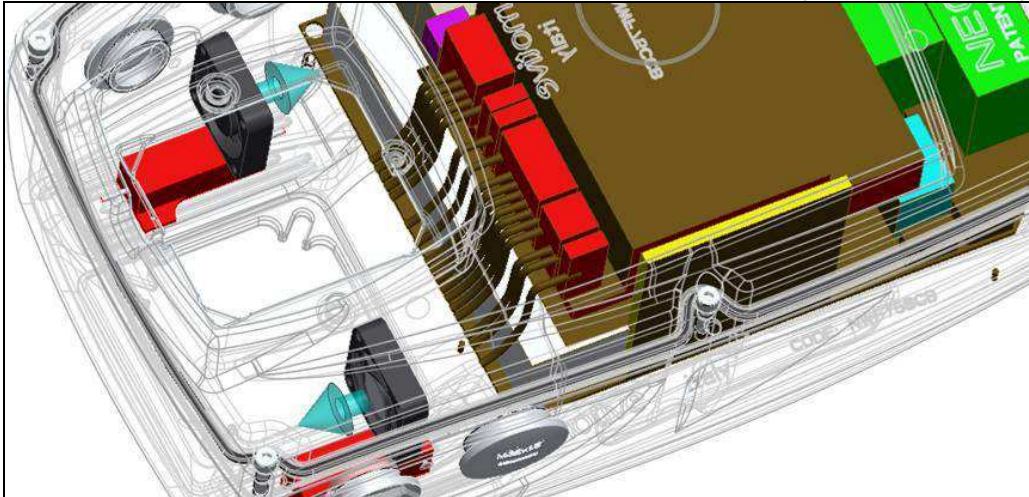

4b.3. Brake motors release lever

In some sizes of self-braking motors, there may be mechanical interference between NEO-WiFi and the release lever of the brake when it is in the upper position. In such cases, the release lever can be disassembled by unscrewing, or, if it should be kept, it is necessary to rotate by 90° (sizes 71-80), or by 120° the rear shield of the motor, together with brake and fan cover. This can only be performed by the factory or by service centres authorized by motive.

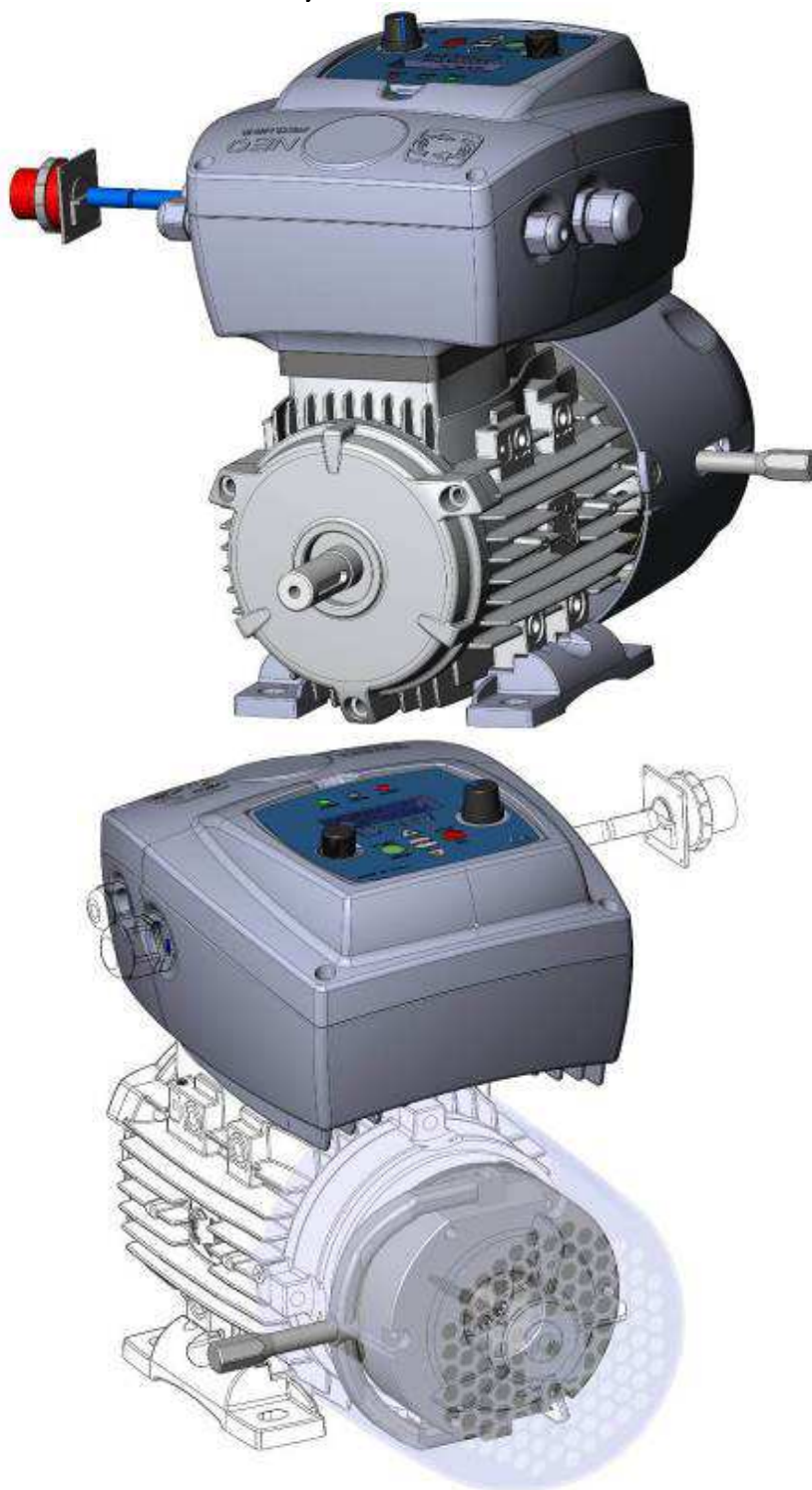

4c. Wall mounting NEO-WALL (option)

If a wall mounting is needed, for example when submersible pump is used, you can use NEO-“WALL” (mounting instructions and electrical connections provided with every kit)

NEO-WALL3



NEO-WALL11



NEO-WALL2

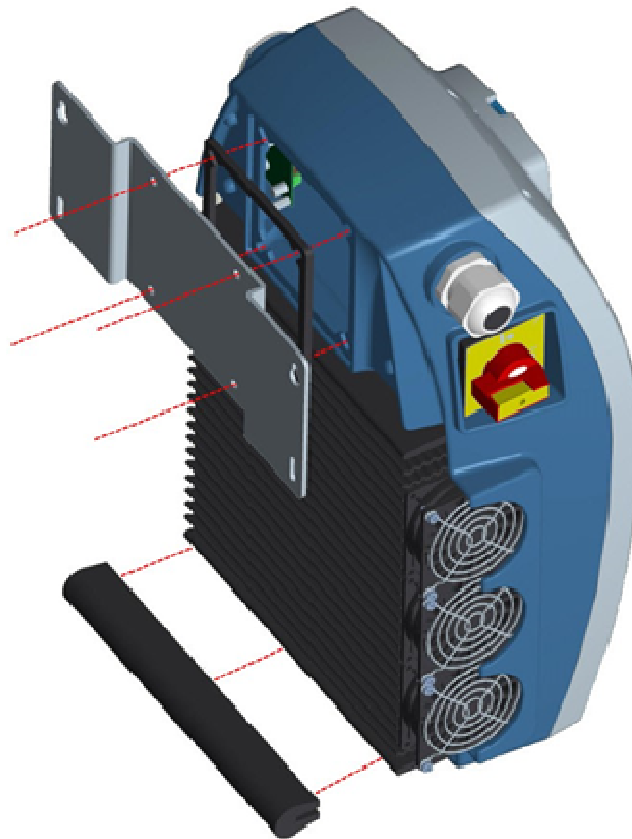

4d. Keypad

The keypad is available in two versions:



Standard version
IP67



Optional version with analog controls
IP65

Thanks to 4 magnets incorporated into the keypad case (Ill. 6), the keypad safely rests in its housing, in any assembly position.



This also offers the advantage of allowing the keypad to be rotated into 4 positions, depending on the preferred point of view



If the keypad is removed from the NEO-WiFi case, it can be fixed to the wall in 2 ways.

- If the wall is made of metal, by using the magnetism of 4 magnets in the keypad (III. 7).



III.7



- Alternatively, it can be fixed onto 2 inserts by using the designated slots on the back of the case (III. 8)

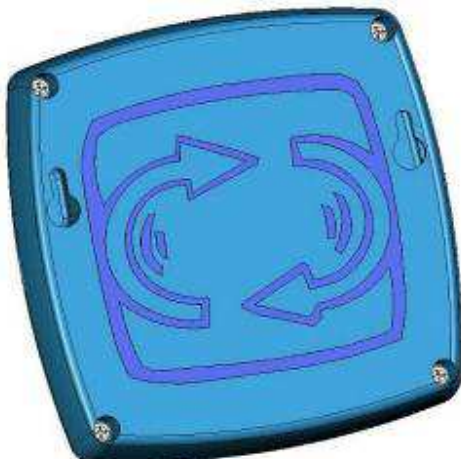

III.8



Each keypad comes equipped with two rechargeable 250BVH batteries (Diameter = 25mm, height 6.4mm, 1.2 Vdc, 250 mAh).

4d.1. Keypad batteries

Before you start to use the keypad for the first time, recharge the batteries, leaving the keypad resting inside its seat in NEO-WiFi (with stopped motor) or inside BLOCK, while BLOCK or NEO-WiFi are powered, for 10 hours

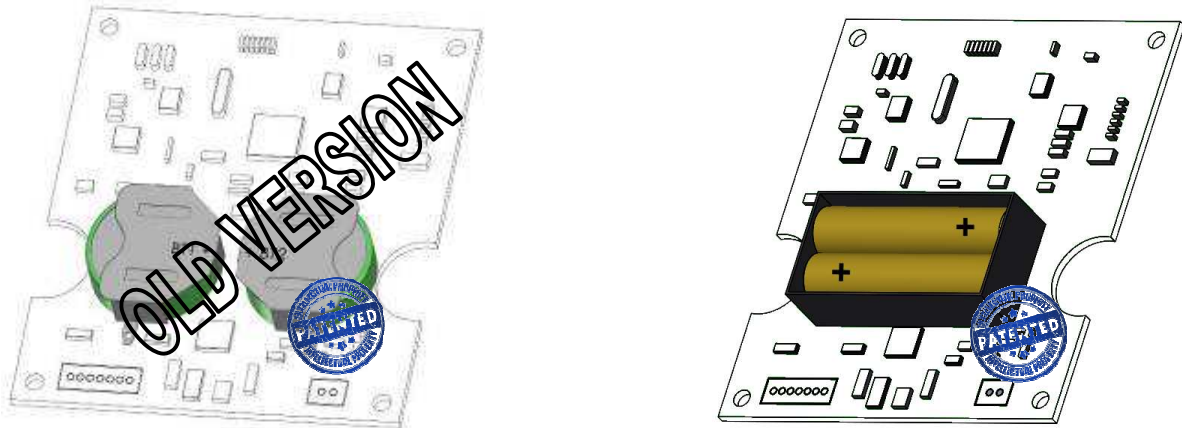
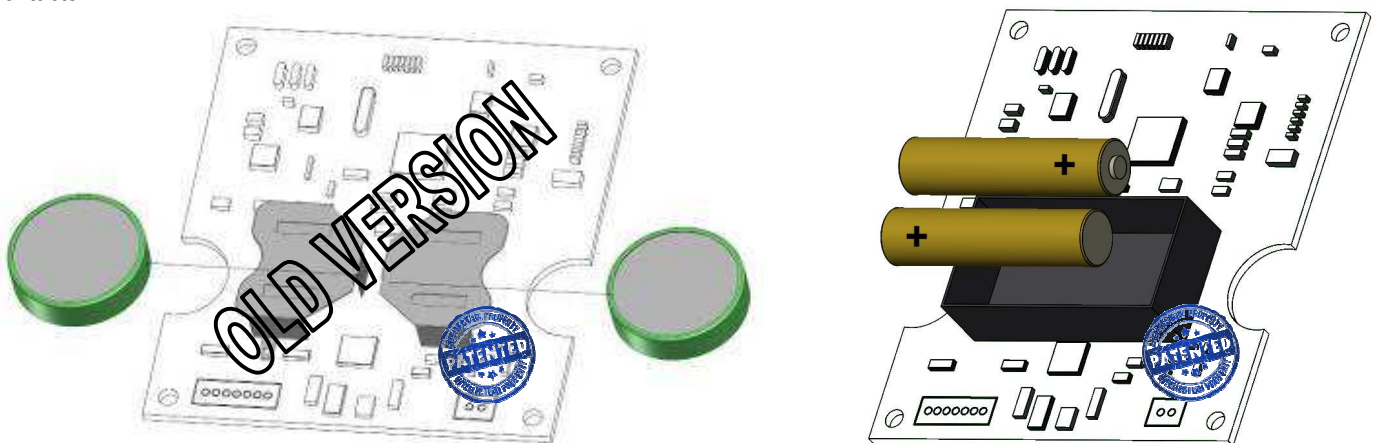

Illustration 14 - Diagram rear NEO-WiFi logic control board

- the rechargeable batteries, if they are regularly charged, can last for several years; if not charged for long periods of time, it may however become necessary to replace the batteries.
- Battery charging time: with display turned on about 1 hour (NB: it is unlikely that the client will uninterruptedly use the buttons for this period of time) – in stand-by mode it will last indefinitely because there is no power use, until the MODE button is pressed that will reactivate the keypad and its screen;
- Full-charge time with keypad in the inverter case or on BLOCK feeder: about 1 hour;

To remove the batteries, open the control panel and move them externally from their slots. Check that there is no oxide on the contacts.



In the presence of selector and potentiometer the 4 M3 screws that are at the top of the display board must be unscrewed. Extract it so that the batteries can be removed and replaced; at the end of this operation the board will need to be screwed back on to the cover of the keypad.
Do not damage the screws' seats by excessive clamping.

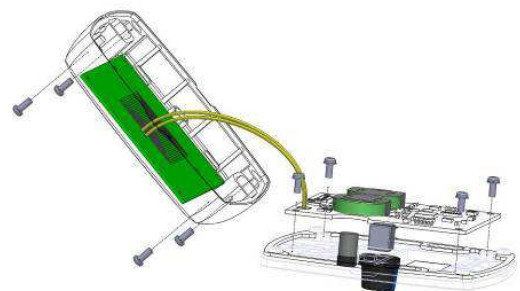

4d.2. BLOCK – induction power charger for table or wall mounting

Voltage supply 200-260Vac 1PH 50/60Hz IP65



The keypad is attracted and hold in BLOCK seat by magnets

The keypad can be positioned in any position.

The keypad is powered by induction.

BLOCK is IP65

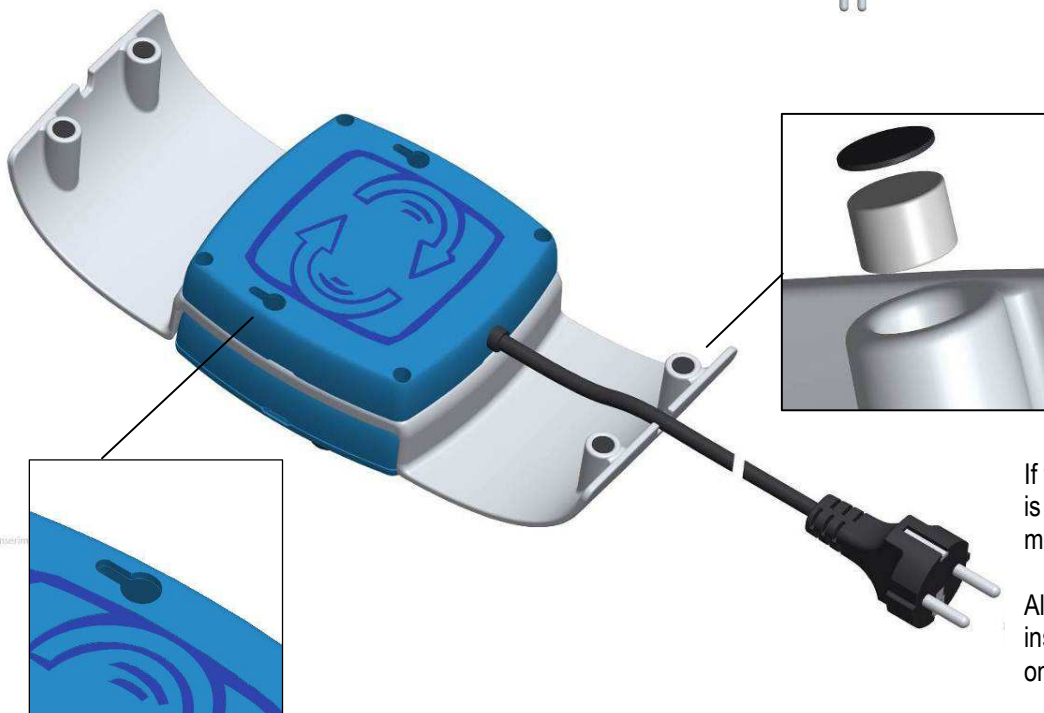

If the wall is made of metal, BLOCK is fixed by the magnetism of its 4 magnets

Alternatively, it can be fixed onto 2 inserts by using the designated slots on the back of BLOCK

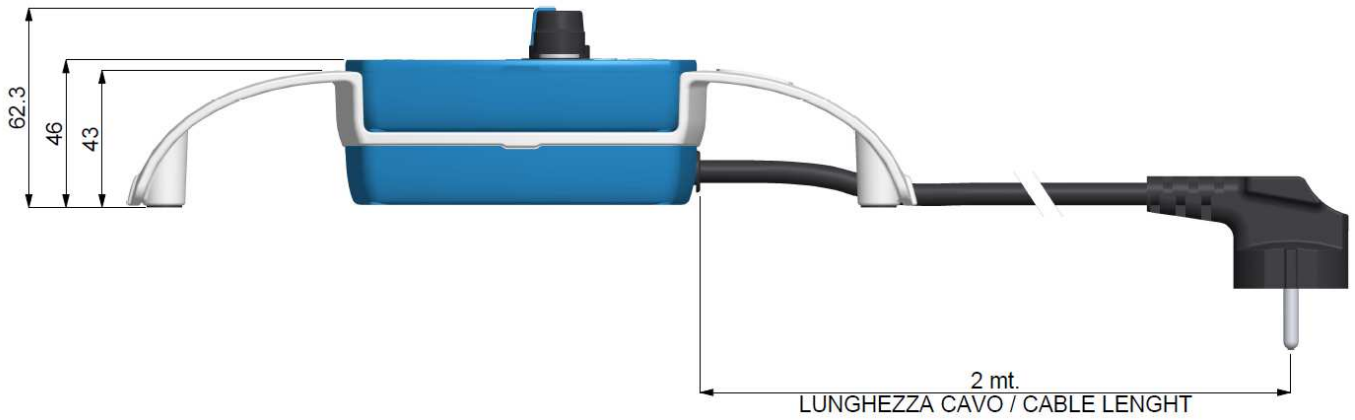

5. ELECTRICAL ASSEMBLY

5a. Warnings



The installation must be carried out exclusively by qualified and expert personnel.

Any handling of the open Inverter box must be done at least 1 minute after the interruption of power, with an appropriate disconnect switch or by manually removing the power cable. To be certain that the internal capacitors are discharged, and that therefore maintenance can be performed, the internal LED located on the lower part (green diode) of the power board, must be completely turned off. Always unplug NEO-WiFi from the power outlet before handling any electrical or mechanical parts of the system.

Read this manual and the engine manual (download from www.motive.it) before installation.

In the event that the product has evident signs of damage, do not proceed with the installation and contact the Service Centre.

Strictly observe the safety and accident prevention regulations.

The mains voltage must match the one required by the inverter (Chap. 2).

Disconnect the power supply of the Inverter by acting on the upstream switch before opening its enclosure;

EMC Directive requires that the both the NEO-WiFi power cables are of the coaxial (or armoured) type with the single conductors having a section greater than or equal to 1.5 mm. The shielding of the conductors must be grounded at both ends.

To avoid ground loops that can cause radiated disturbance (antenna effect), the motor driven by NEO-WiFi must be grounded individually, always with a low-impedance connection.

The paths of the main and motor-inverter power cords should be separated as much as possible. Do not create loops. If they should intersect, make sure it is at 90 degrees to produce the least coupling. Failure to comply with these conditions may completely or in part nullify the effect of the anti-disturbance filter.

In some cases, to completely eliminate some disturbances (radiated or conducted) that other very sensitive plant equipment may be subject to, another three-phase EMC mains filter must be used, (Minimum rated current 8 amps) connected upstream, as input to the inverter.

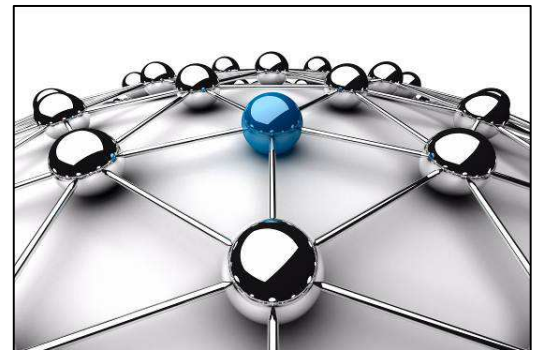

5b. Electrical connection of NEO-WiFi

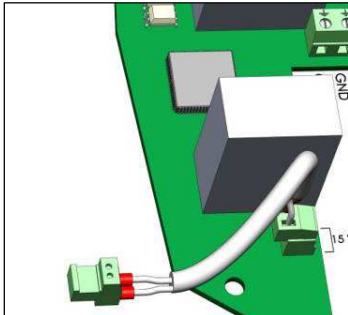

- Open the inverter box by unscrewing the 4 screws of the lid;
- Disconnect the connectors of the coaxial cable of the antenna (ANT) and the inductive power supply (15Vac) – (Ill. 13) – to completely separate the lid from the bottom of the inverter box, to facilitate the mounting on the motor;
- Connect the terminals of the motor terminal box to NEO-WiFi connectors as shown in the Ill. 9, 10, 11, or 12.

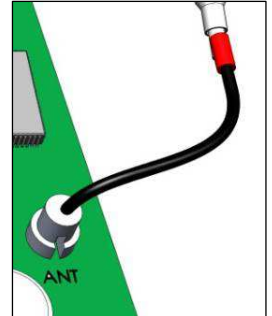

NEO-WiFi-11+22:

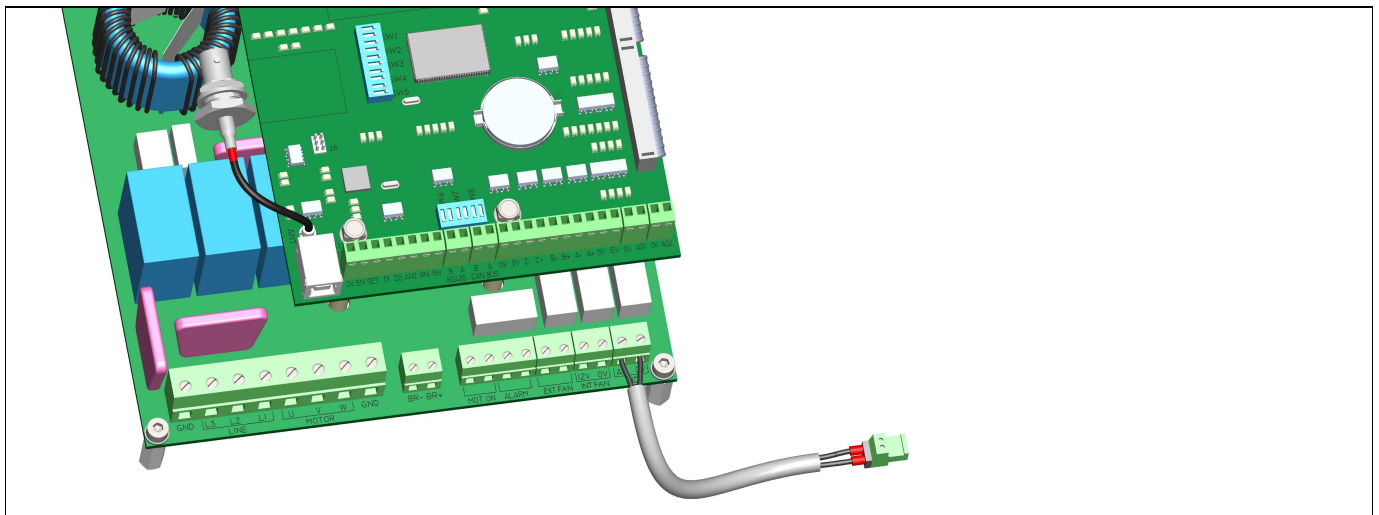







COAXIAL CABLE CONNECTOR ON THE POWER BOARD: When connecting the coaxial cable to the power board, do not use metal tools that may damage the surrounding SMD electrical components that are extremely delicate.

5b.1. Protection and safety devices

- In conformity with the Machinery DIRECTIVE 2006/42/EC Section 1.2.4.3. it is necessary to install an emergency stop device that can be used as a backup to the stop solution provided by the NEO-WIFI control panel. Such a device must be in a position from which the machine and its functioning is constantly and clearly visible.
- It is required that the system conforms to current safety regulations.
- Prepare an adequate general protection against short-circuits on the power line.

POWER SUPPLY - EXTERNAL DEVICES CONNECTION

	Three phase AC current power supply	Use one within the limits of the NEO-WIFI as stated in this manual.
	▼ Earth leakage circuit breaker (differential)	Automatic differential switch with $I_{\Delta n}=300\text{mA}$, B type .
	▼ Line contactor	Useful to switch off the power supply if commanded by a safety circuit. Not to be used to start the system. Type AC1.
	▼ Protection fuses	Compulsory. A fuse is a protection against short circuits. Instead, a magneto-thermal switch would be an overload protection based on absorbed current, but this protection is already incorporated in NEO.
	▼ Line choke (Reactor)	Useful for improving the power factor limiting the harmonics in line, or in the vicinity of large power systems (transformation cabins). Compulsory when the distance between motor and inverter (see wall mounting system) is higher than 50mt.
	▼ Motoinverter	The direct connection with the motor cancels the need for shielded cables compared to a conventional inverter. In case of using NEO WI-FI not on board, use shielded cables and, if the distance to the motor exceeds 25mt, use a series inductance.

5b.1.1. Dimensioning of protection and safety devices

MOTOR POWER	RECOMMENDED FUSE 500VAC CL.H or K5	RECOMMENDED INDUCTANCE	RECOMMENDED CONTACTOR	POWER CABLES SECTION mm ²
Up to 0,37kw at 230Vac	10A	3mH	25A	2,5
Up to 1,1kw at 230Vac	10A	2mH	25A	2,5
Up to 1,8kw at 230Vac	15A	2mH	25A	2,5
Up to 3kw at 230Vac	25A	1,25mH	45A	2,5
Up to 4kw at 230Vac	40A	1,25mH	45A	4
Up to 5,5kw at 230Vac	40A	0,70mH	60A	6
Up to 9,2kw at 230Vac	50A	0,51mH	100A	10
Up to 11kw at 230Vac	70A	0,30mH	100A	16
Up to 0,37kw at 400Vac	5A	3mH	25A	2,5
Up to 0,75kw at 400Vac	10A	3mH	25A	2,5
Up to 1,5kw at 400Vac	10A	3mH	25A	2,5
Up to 2,2kw at 400Vac	10A	2mH	25A	2,5
Up to 4kw at 400Vac	20A	2mH	25A	2,5
Up to 5,5kw at 400Vac	20A	1,25mH	25A	4
Up to 7,5kw at 400Vac	30A	1,25mH	45A	4
Up to 11kw at 400Vac	35A	0,70mH	45A	6
Up to 15kw at 400Vac	45A	0,50mH	60A	16
Up to 18,5kw at 400Vac	60A	0,50mH	100A	16
Up to 22kw at 400Vac	70A	0,30mH	100A	20

The breaking short circuit devices paired with this range must be at least 10KA, if installed in public supply networks. When connecting to a network from a transformer substation dedicated, you must know the value declared by the supplier of the line and use suitable equipment.

Ensure ground connection of the motor inverter with total resistance of less than 100 milliohms.

5b.2. Connection to the motor

NEO-WiFi must be installed on a three-phase asynchronous motor. Below, we show what to do with the Delphi line standard motors and motive ATDC line self-braking motors.



GROUNDING CONNECTIONS, important for the electrical safety of people and to suppress electromagnetic interference conducted in the mains:

- Small yellow/green cable with M5 eyelet on one side and pre-insulated point on the other, to be connected between the motor frame and GND input on the power board.
- Yellow/green ground wire of the mains supply cable 400 V to connect to the other GND input of the terminal box on the power board.

5b.3. Diagrams

NEO-WiFi-3 - NEO-WiFi-4 - NEO-WiFi-5.5. The phases of the motor must be in a star connection  if the motor has 230V Δ /400VY on the plate (Ill.9).

Ill. 9

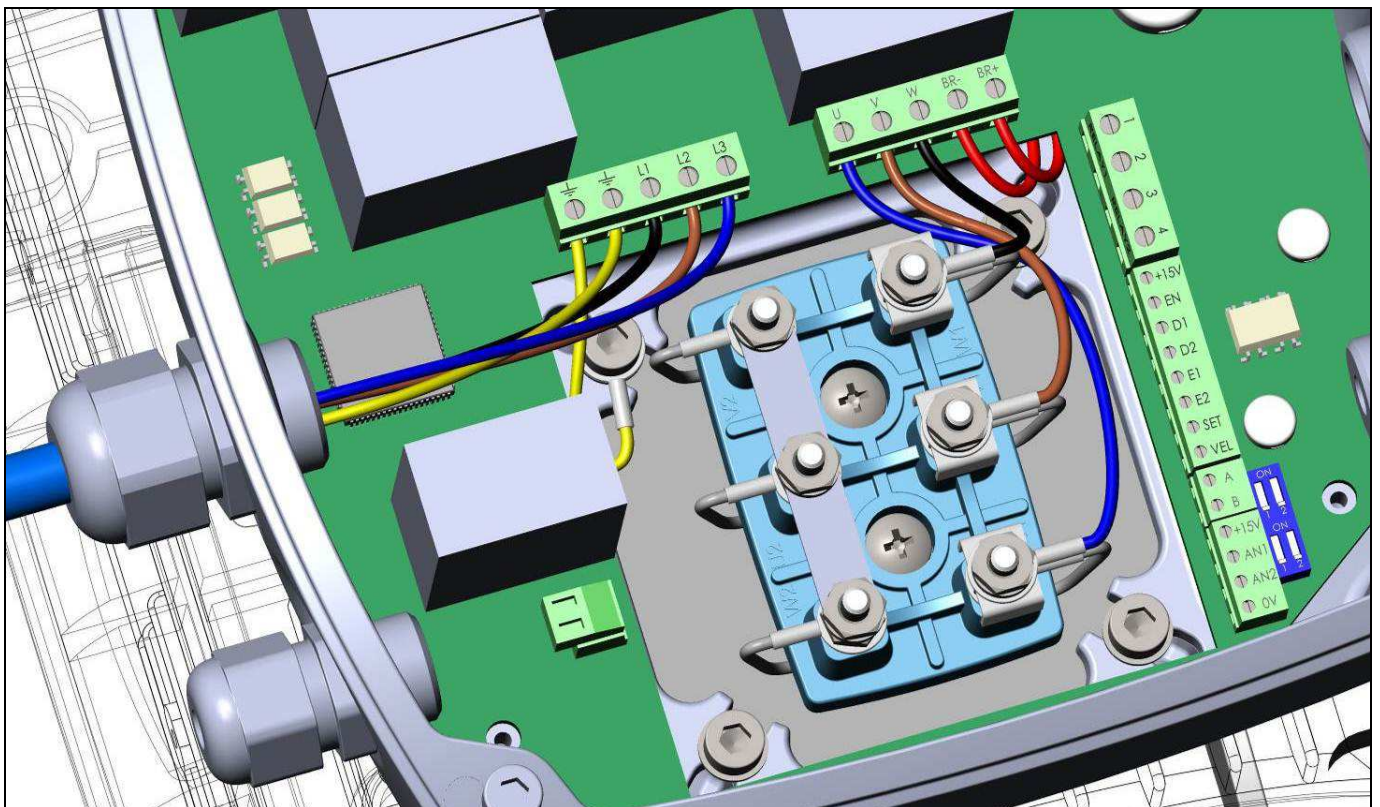
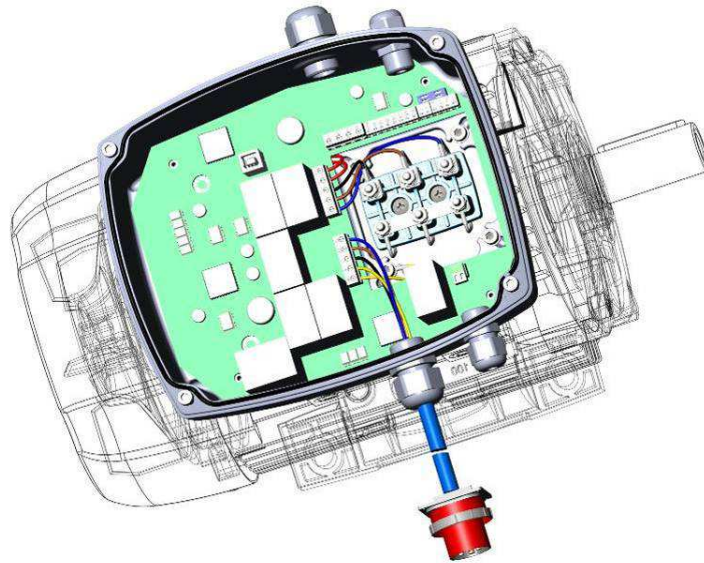

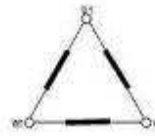

NEO-WiFi-3 - NEO-WiFi-4 - NEO-WiFi-5.5. The phases of the motor must be in a delta connection if the motor has 400V Δ /690VY or 230V Δ /400VY on the plate with 87Hz technique (chap. 5d) (III.10).

III.10

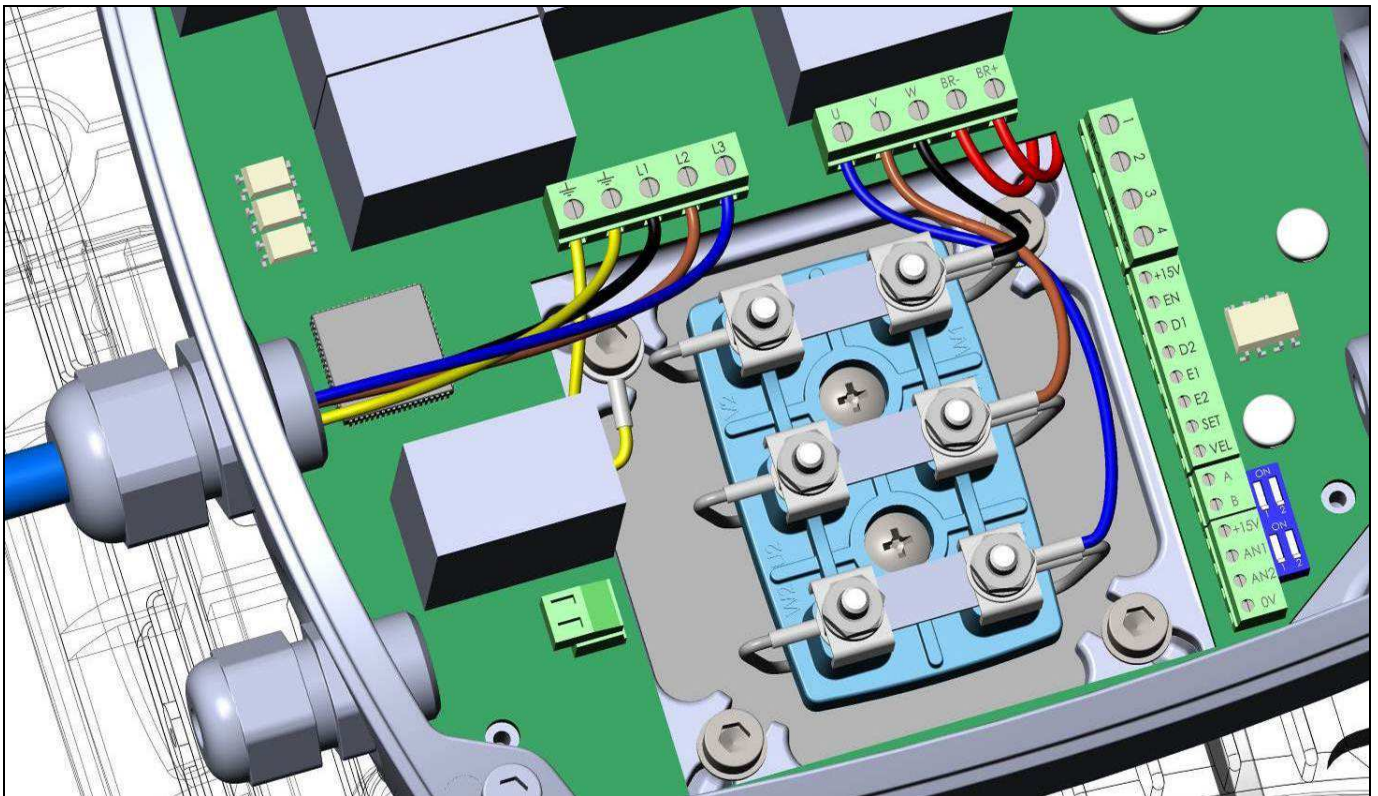
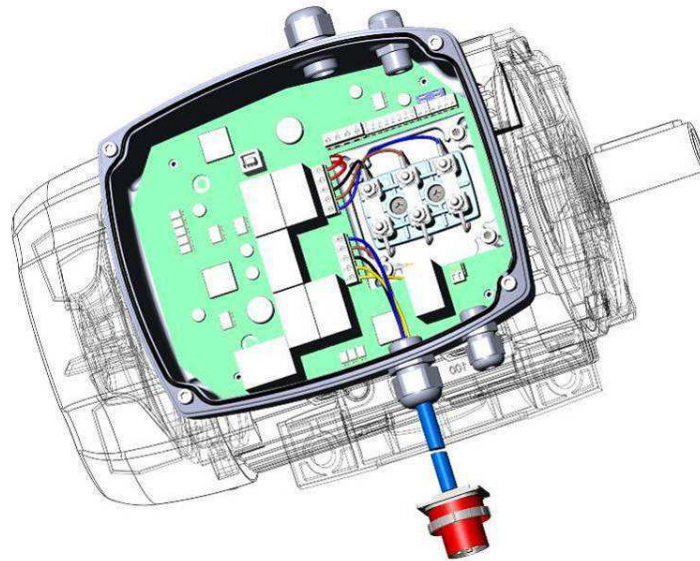

ATDC230VΔ/400VY + NEO-WiFi-3 - NEO-WiFi-4 - NEO-WiFi-5.5

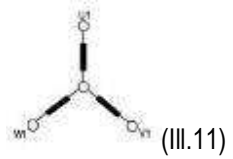

(III.11)

(III.11)

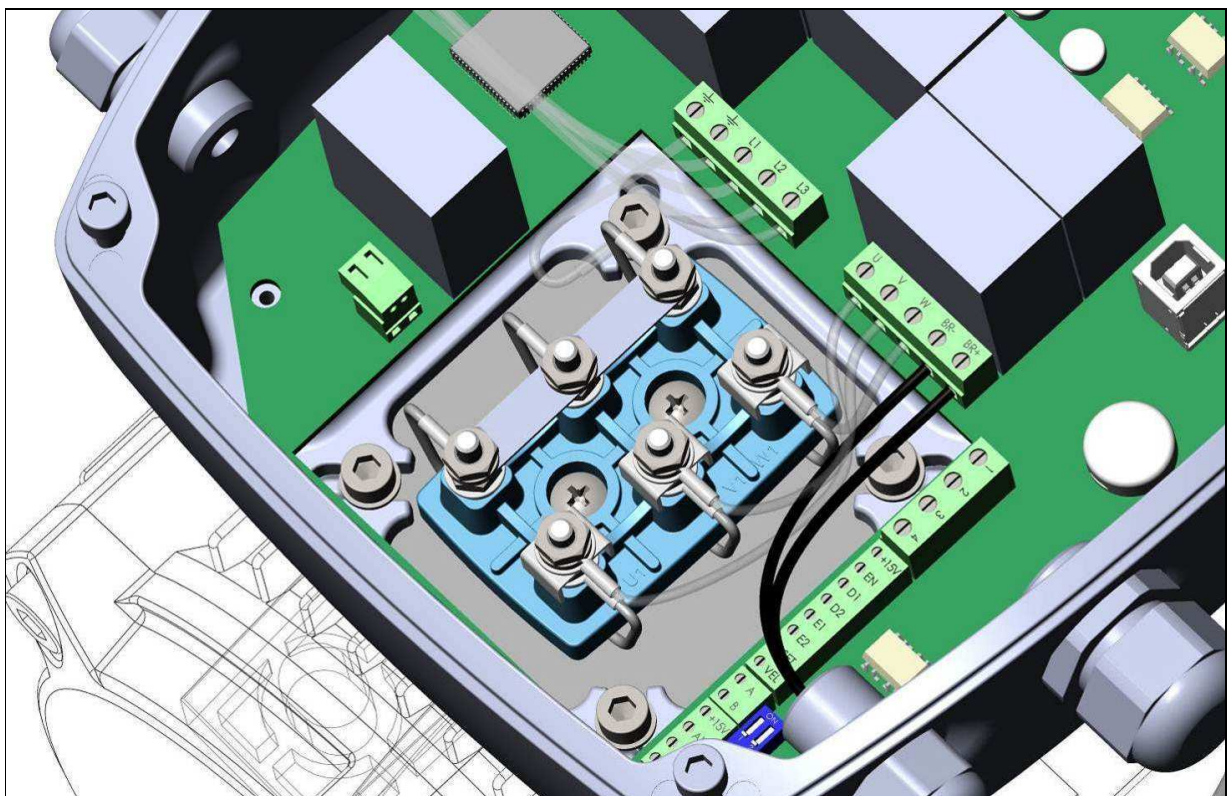
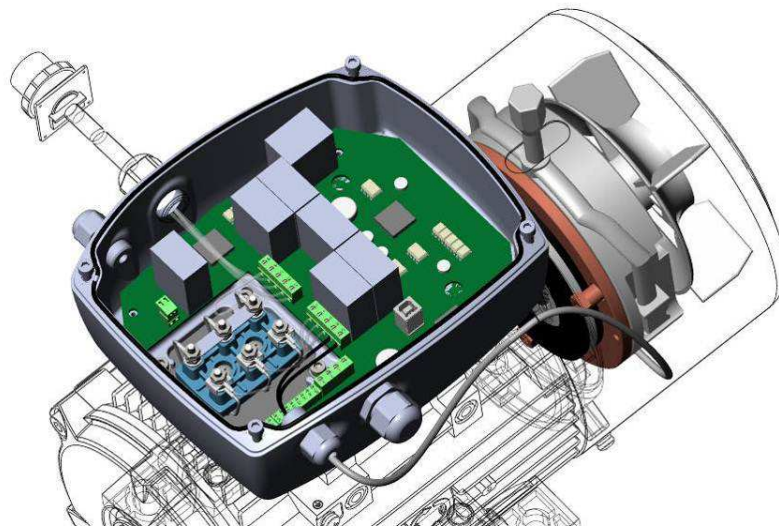

ATDC400VΔ/690VY + NEO-WiFi-3 - NEO-WiFi-4 - NEO-WiFi-5.5

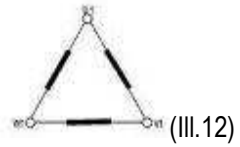

(III.12)

(III.12)

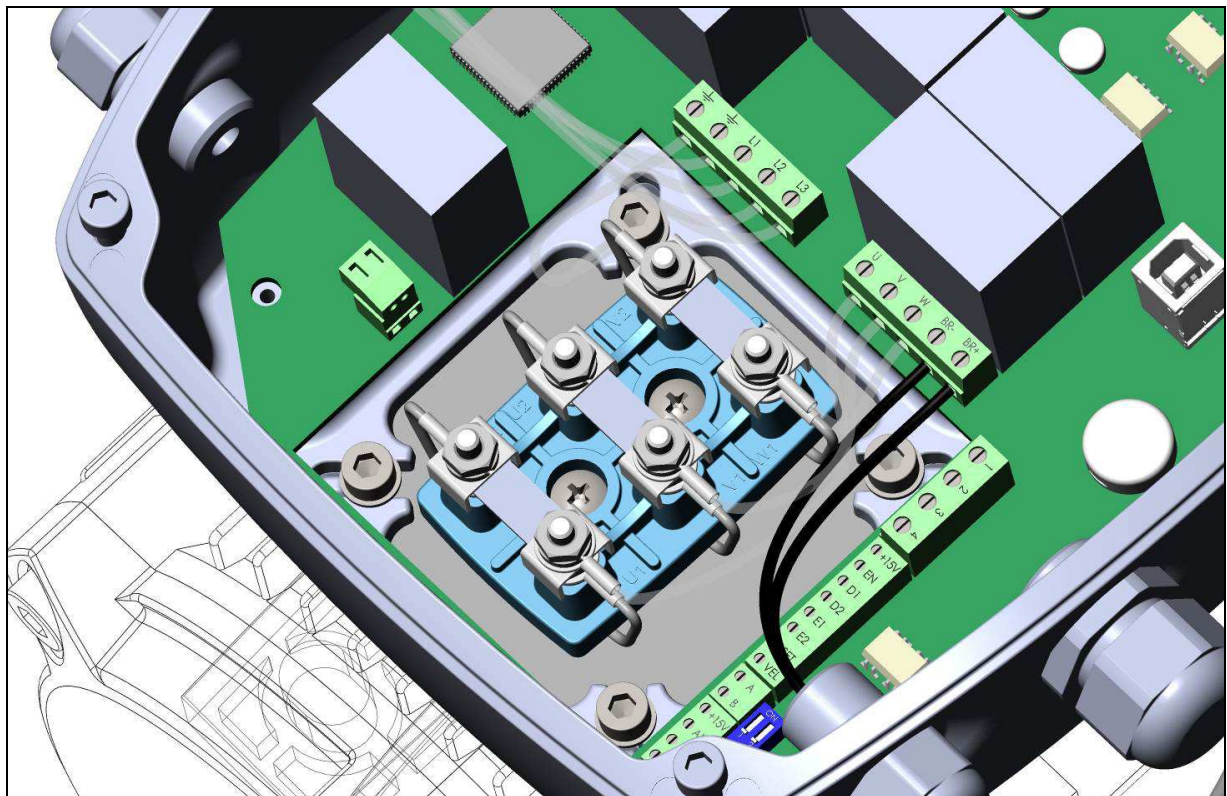
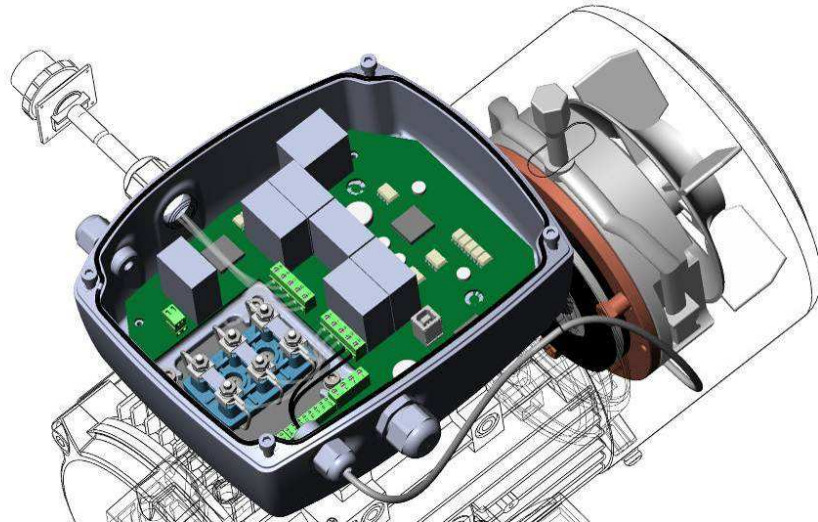

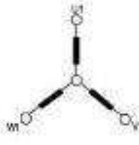
NEO-WiFi-11 - NEO-WiFi-22. The phases of the motor must be in a star connection  if the motor has 230VΔ/400VY on the plate (Ill. 9 (11)).

Ill. 9 (11)

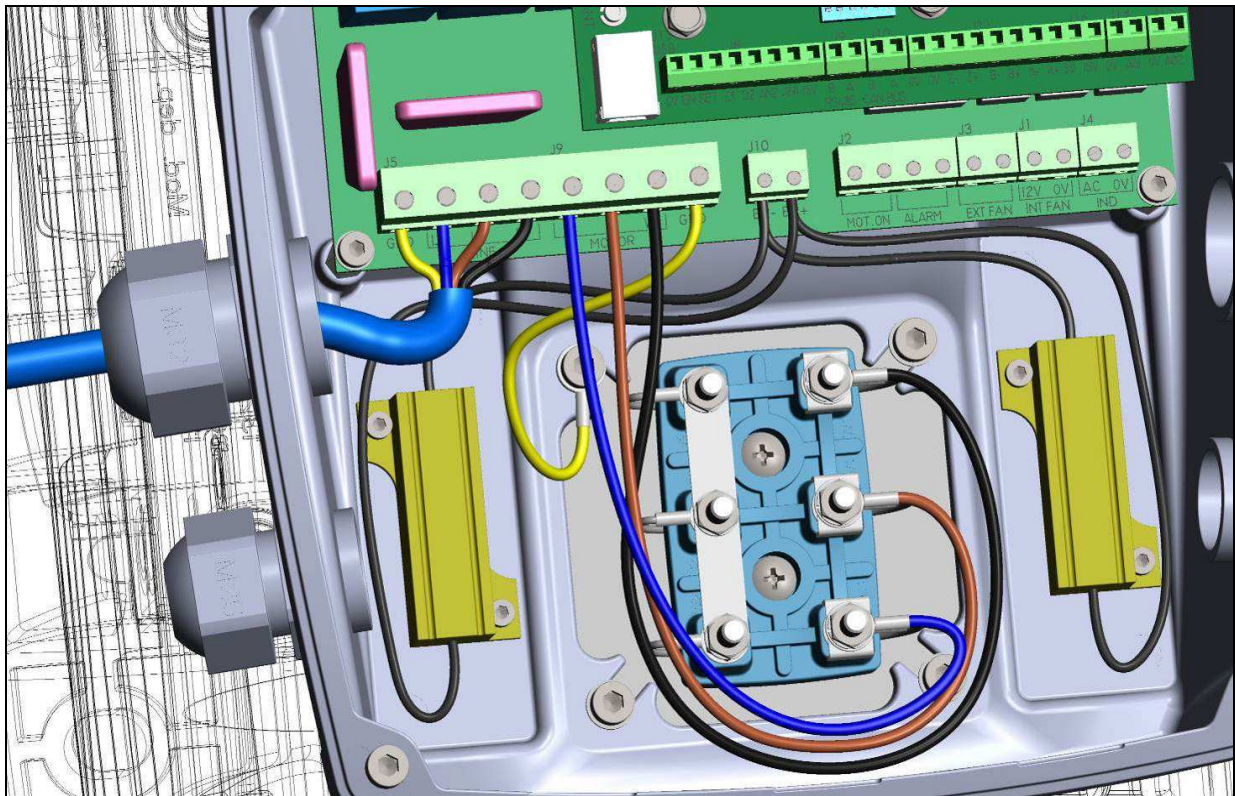
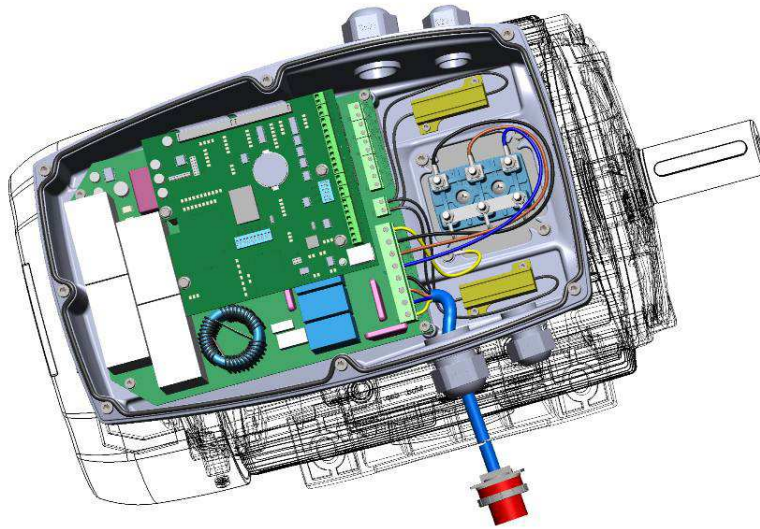

NEO-WiFi-11 - NEO-WiFi-22. The phases of the motor must be in a delta connection

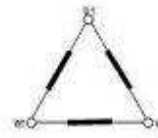

if the motor has 400V Δ /690VY or 230V Δ /400VY on the plate with 87Hz technique (chap. 5d) (III.10 (11)).

(III.10 (11))

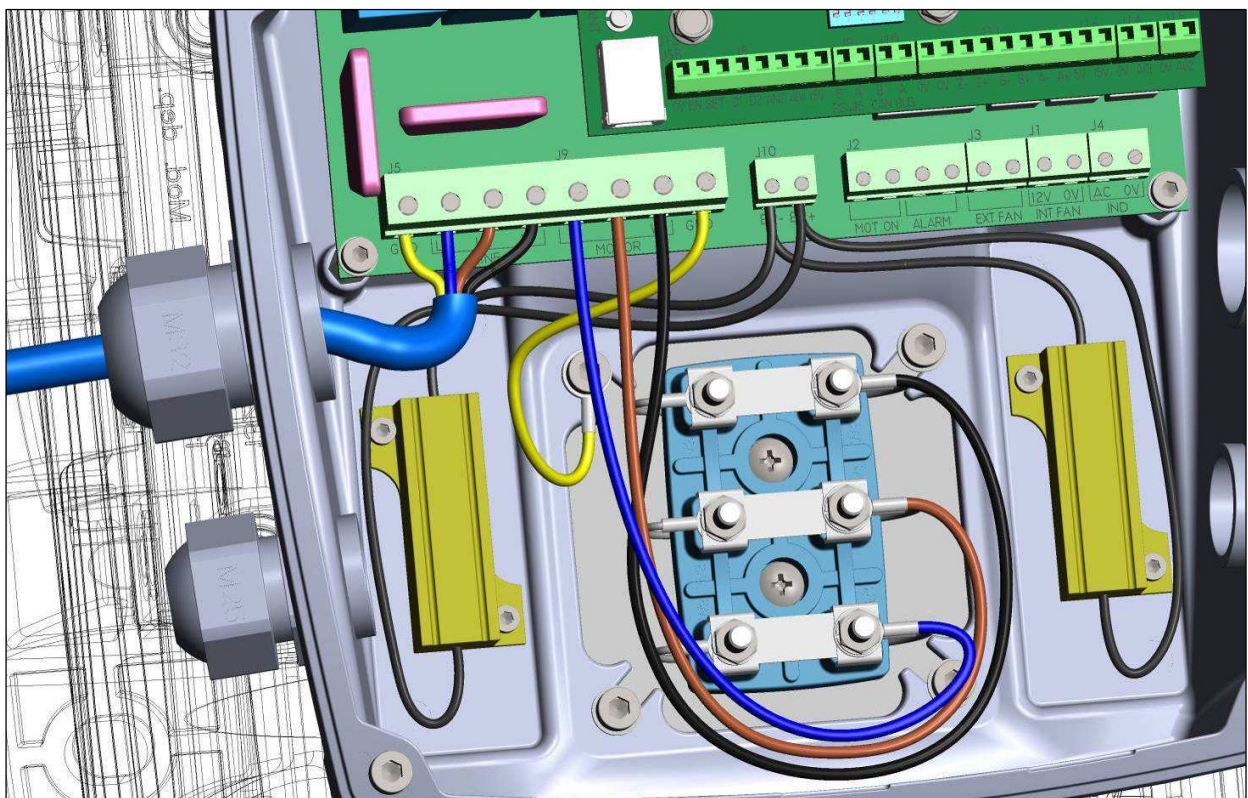
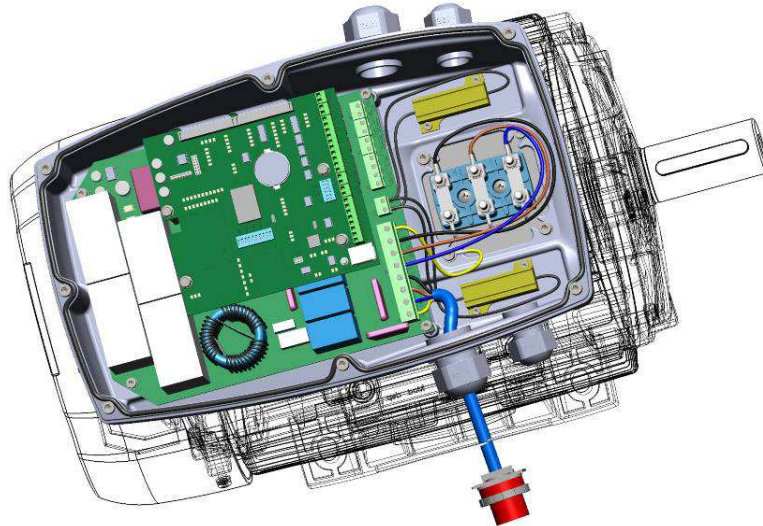

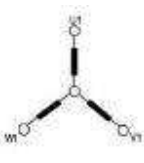
ATDC230VΔ/400VY + NEO-WiFi-11 - NEO-WiFi-22  (III. 11 (11))

(III. 11 (11))

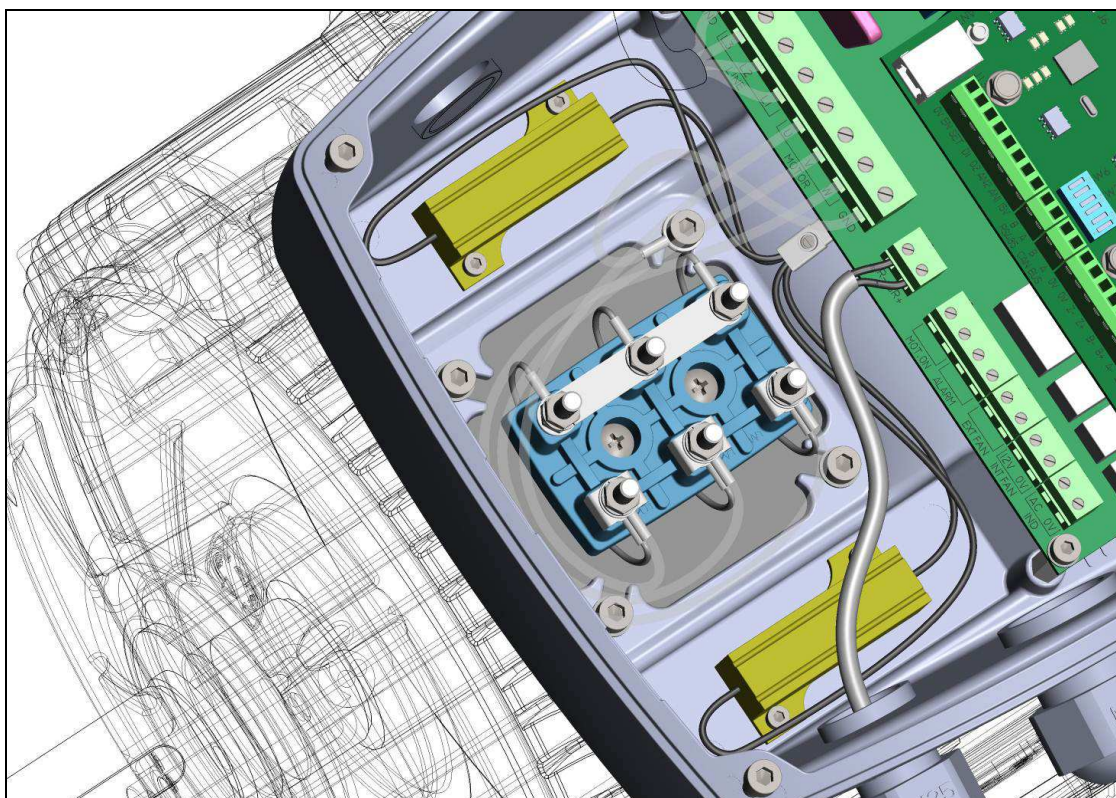
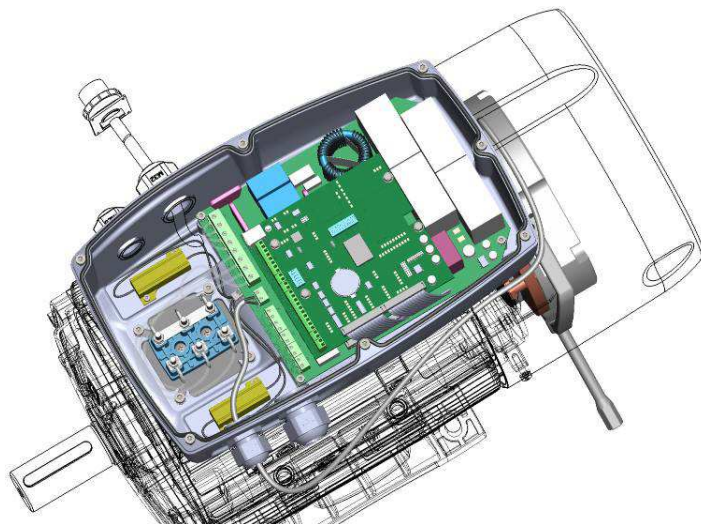

ATDC400VΔ/690VY + NEO-WiFi-11 - NEO-WiFi-22  (III. 12 (11))

(III. 12 (11))

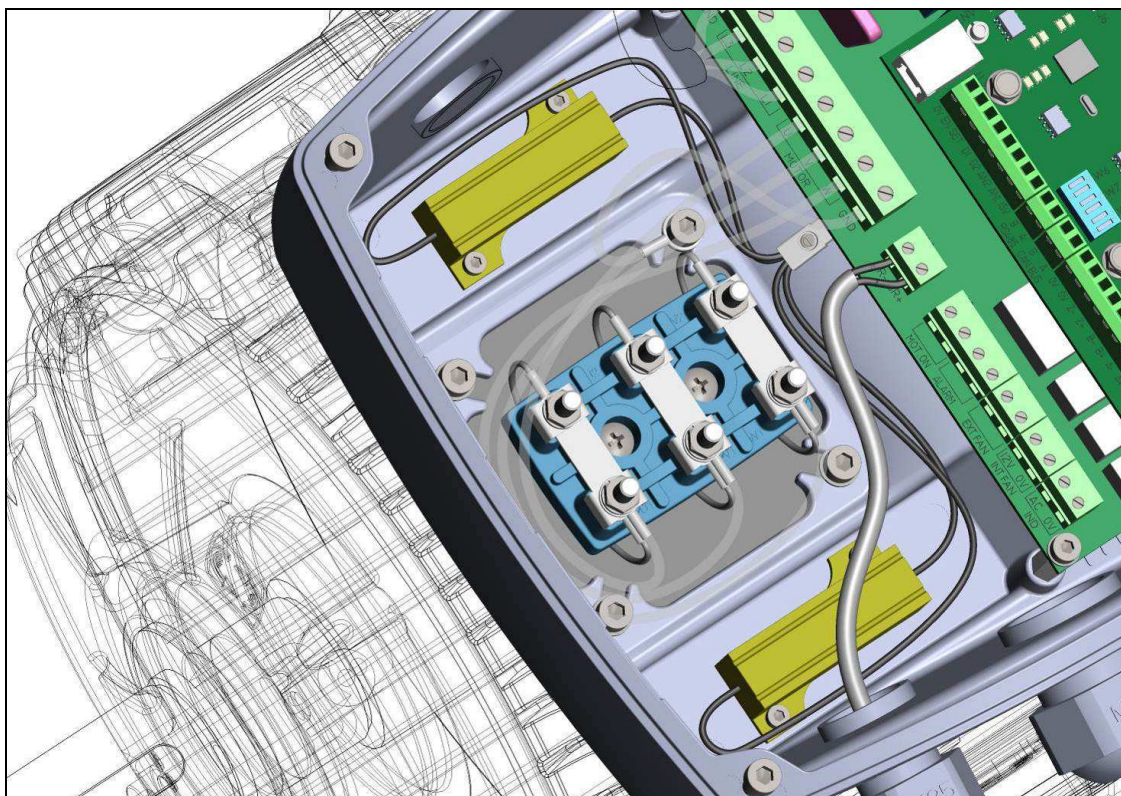
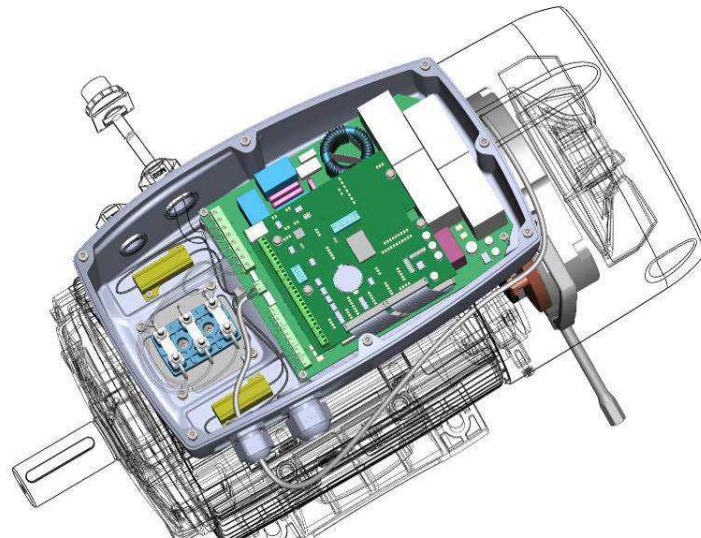



Before connecting the brake wires to the BR + and BR- terminals, disconnect from the same terminals the wires of the internal resistances and isolate them, thereby preventing them from exploding (by setting the relative function in the menu, the warning appears on the display).

NEO-WiFi-3 - NEO-WiFi-4 - NEO-WiFi-5.5

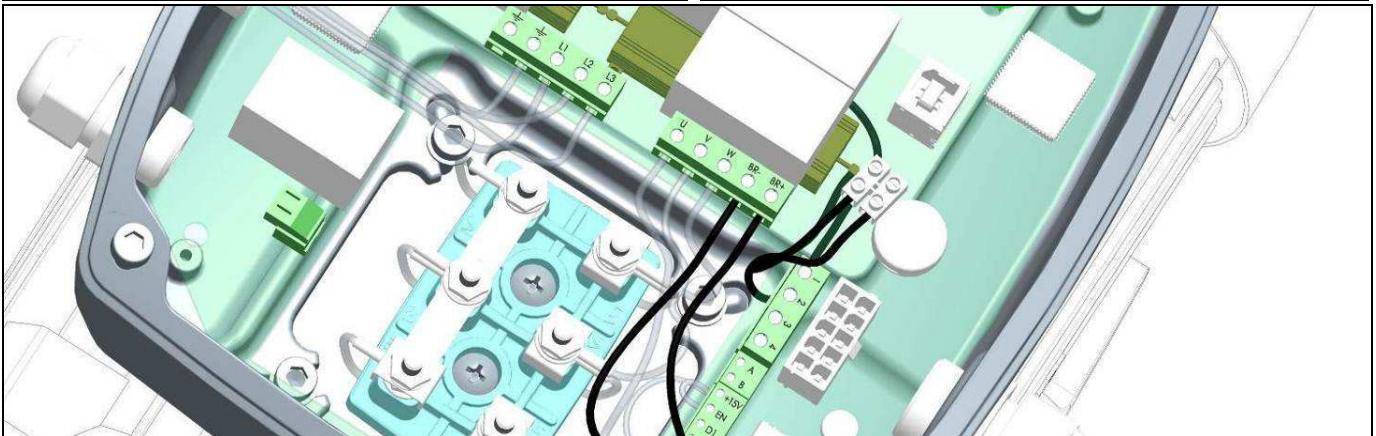
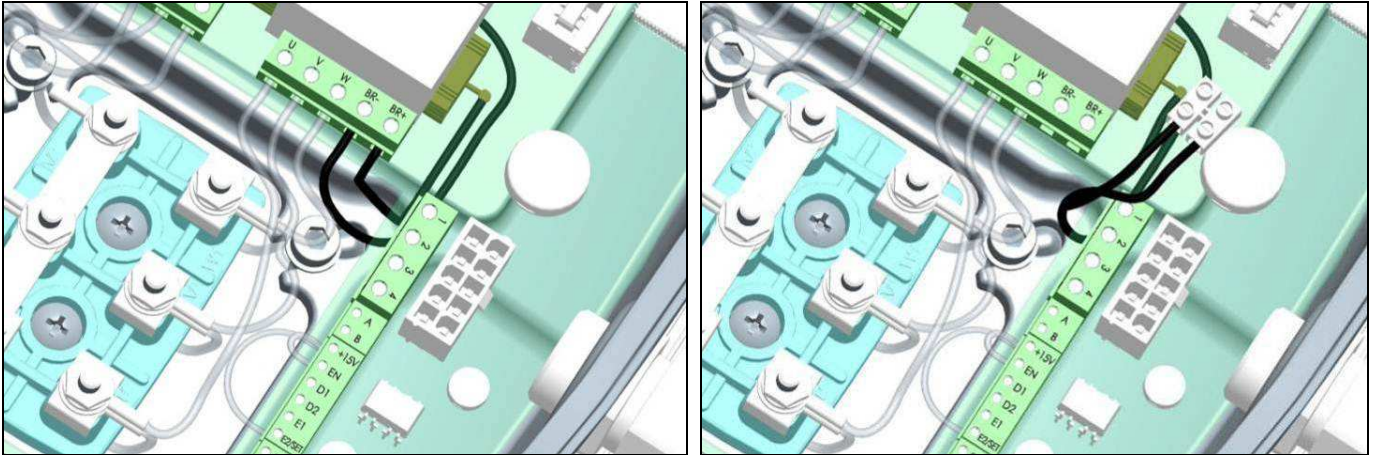

NEO-WiFi-11 - NEO-WiFi-22

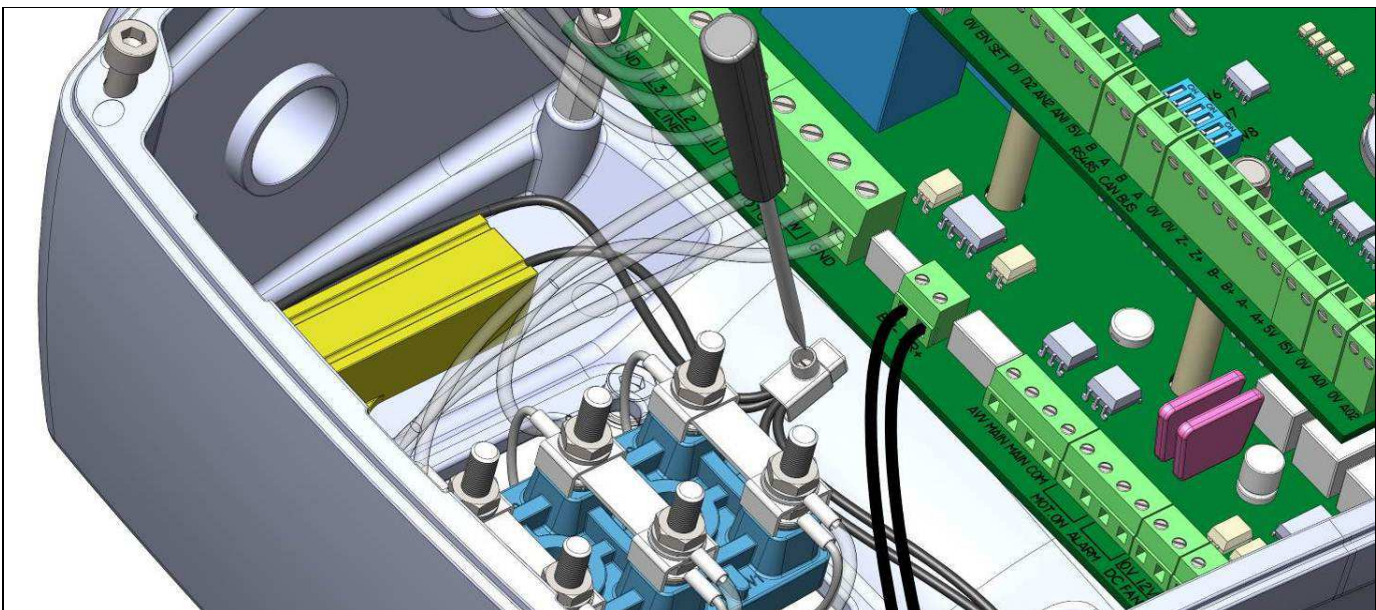

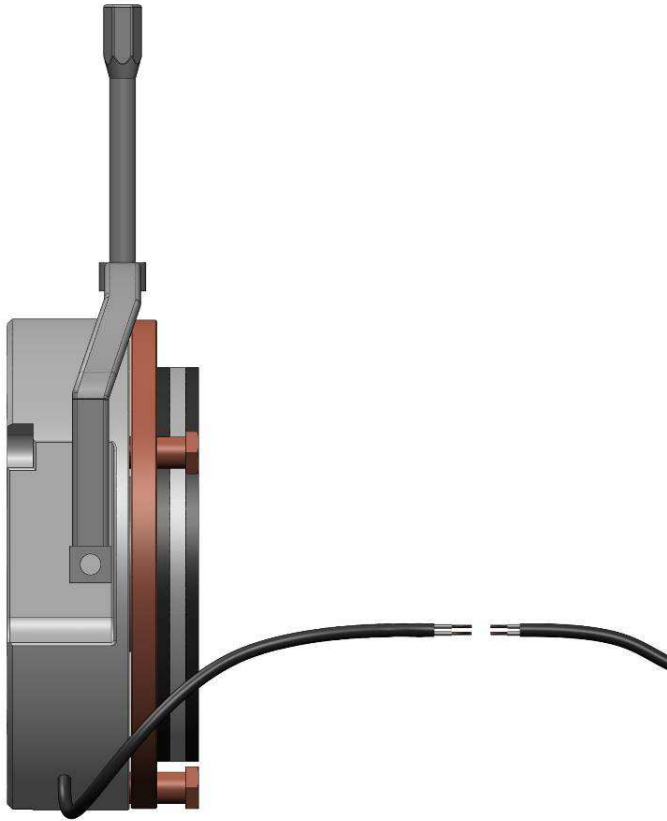

If the brake cable is too short to reach NEO-WiFi terminals, extend it in a way that insulation, and needed IP are guaranteed. In the following pictures, we show the method of the heat-shrink tubing

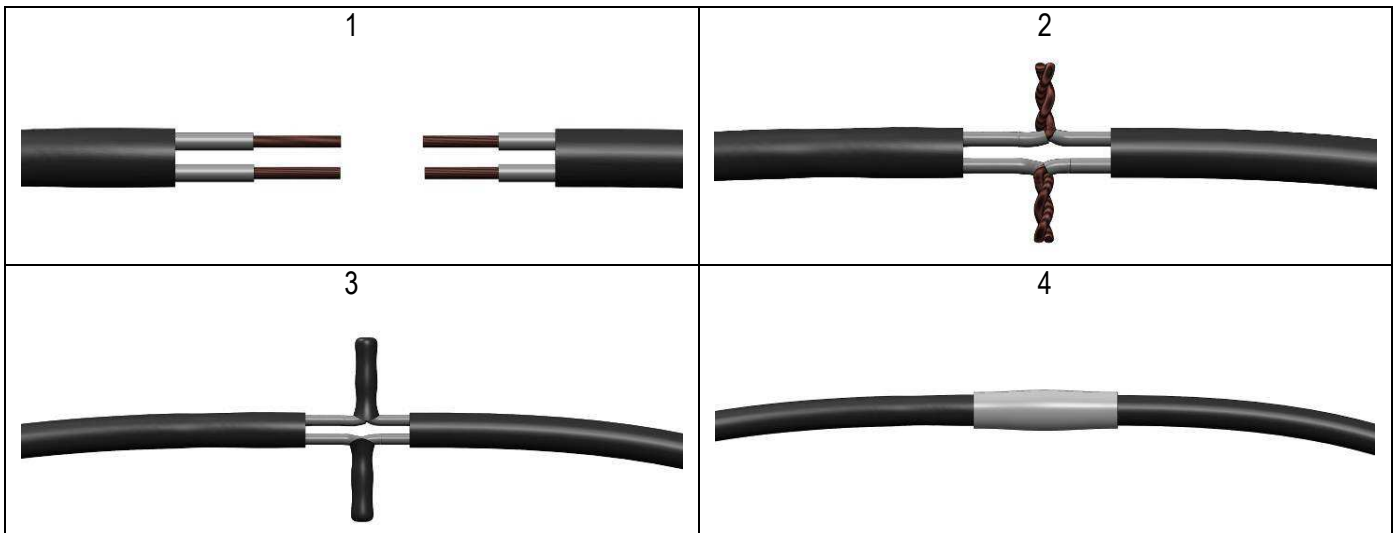

GENERAL WIRING DIAGRAM

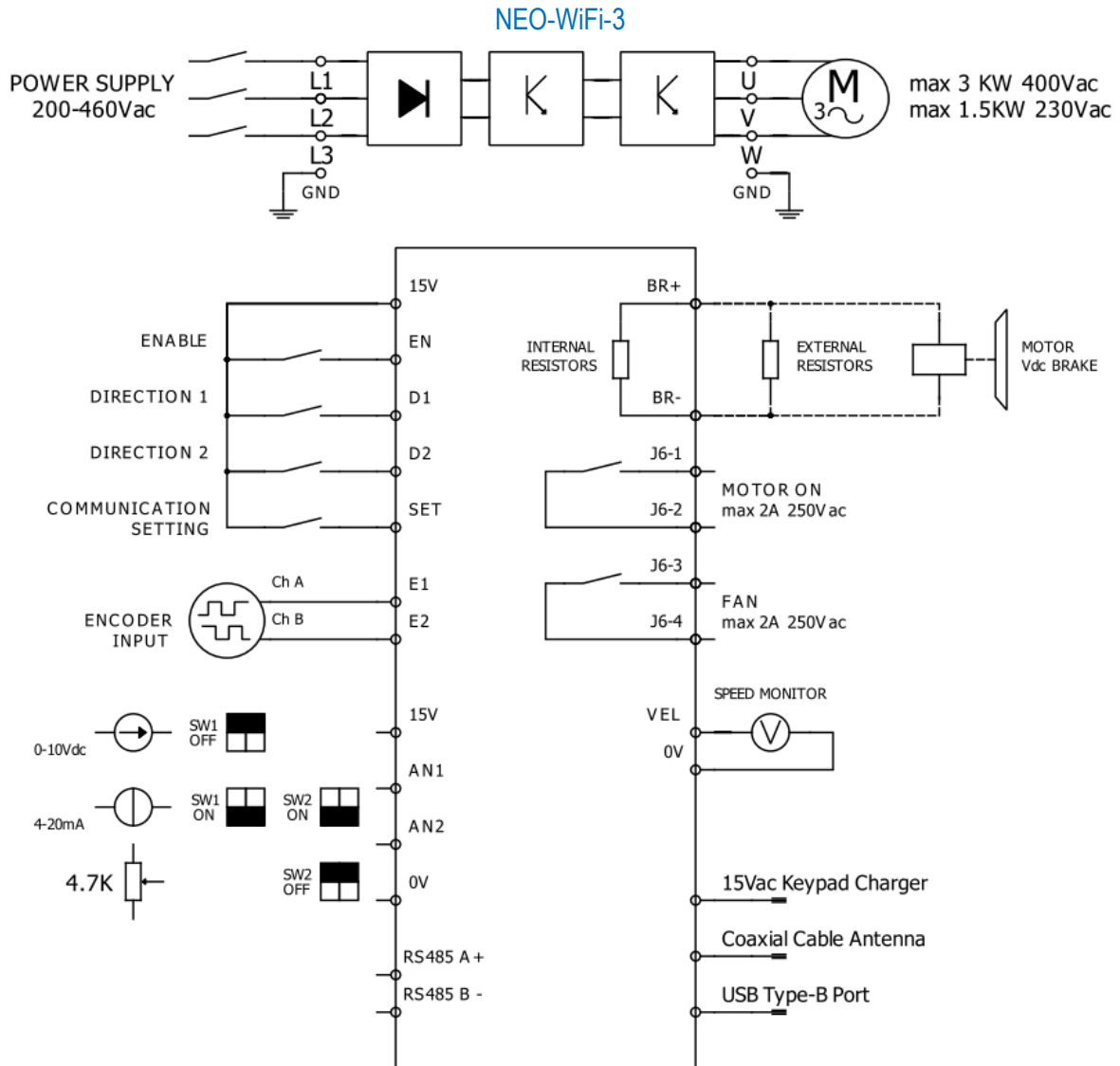

NEO-WiFi-4

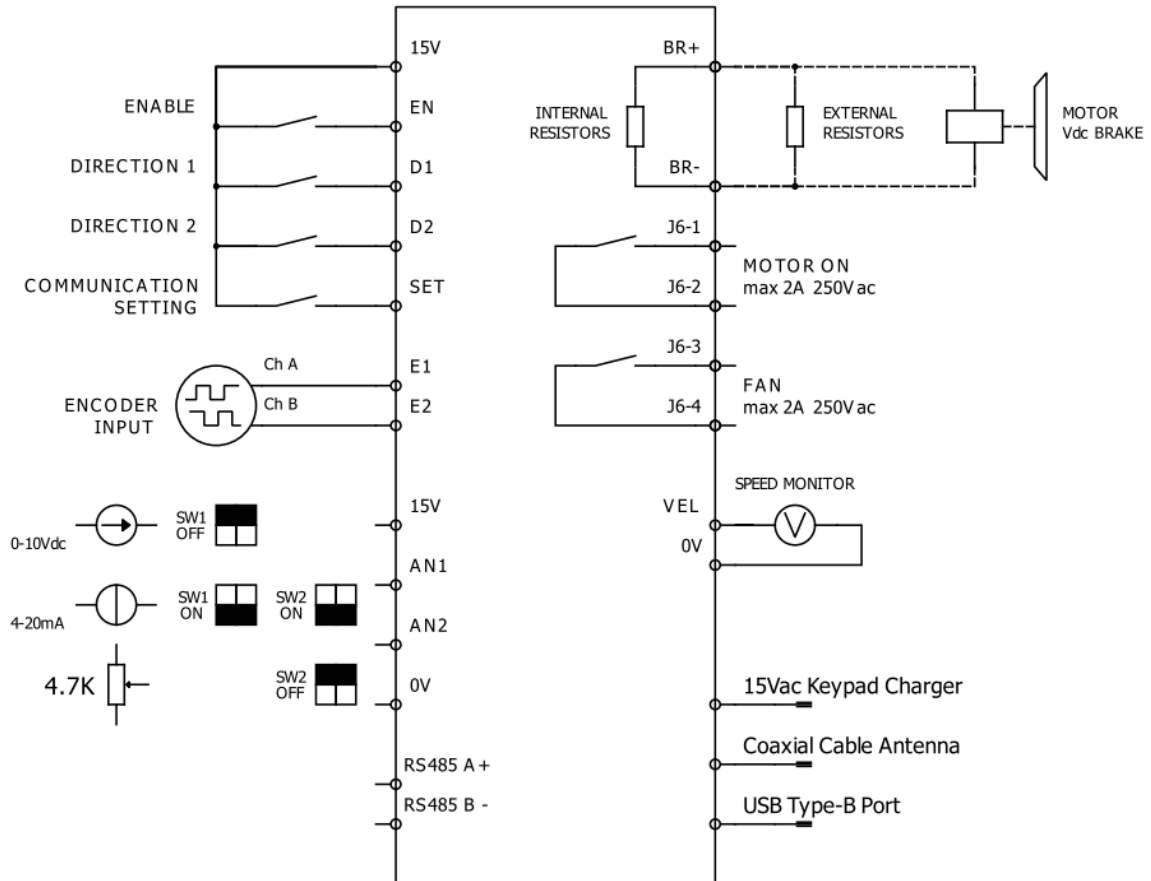
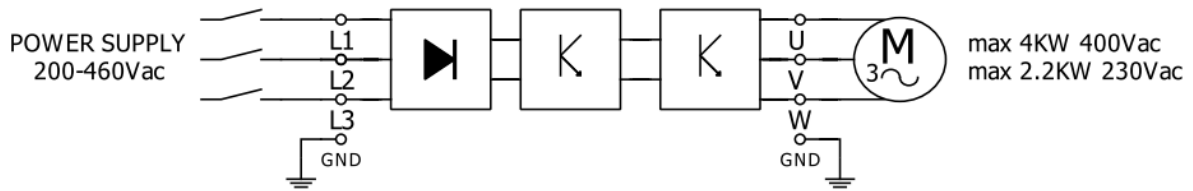

NEO-WiFi-5.5

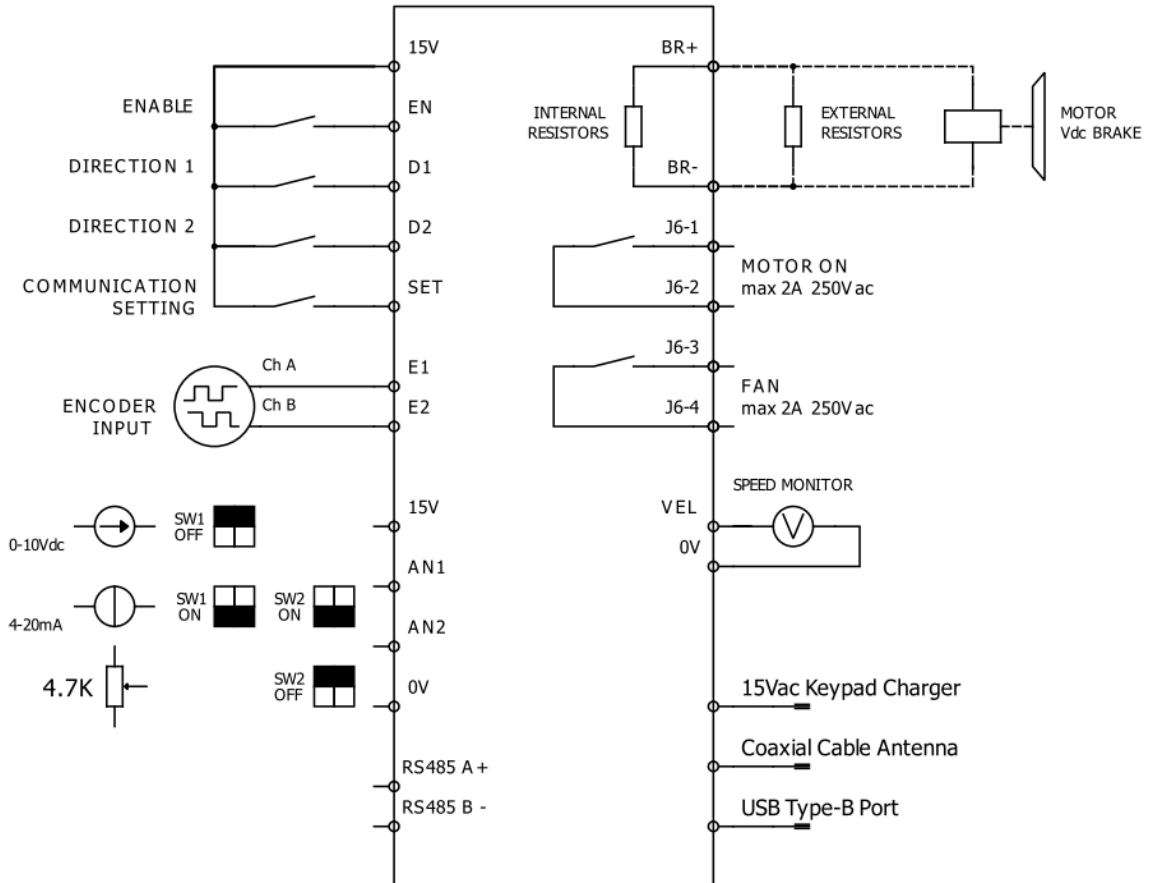
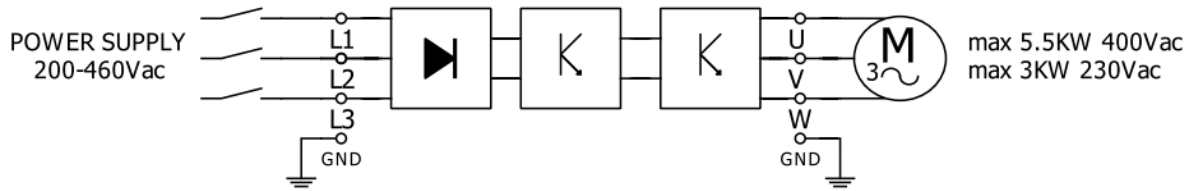

NEO-WiFi-11

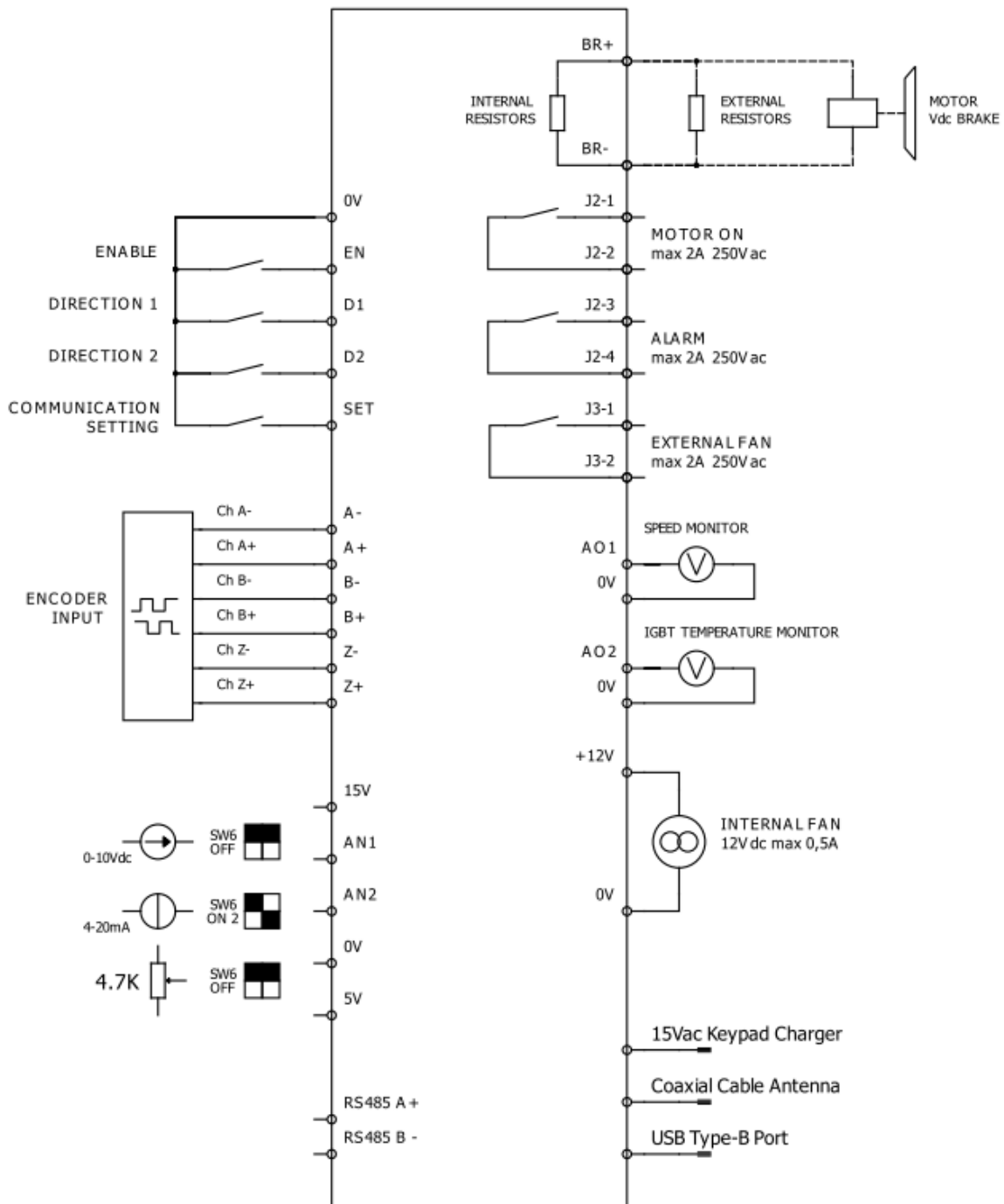
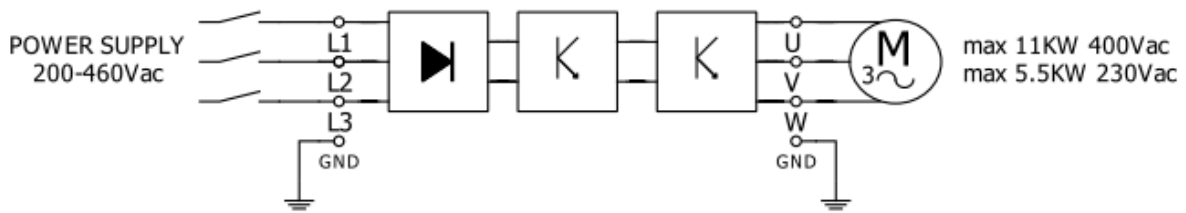

NEO-WiFi-22

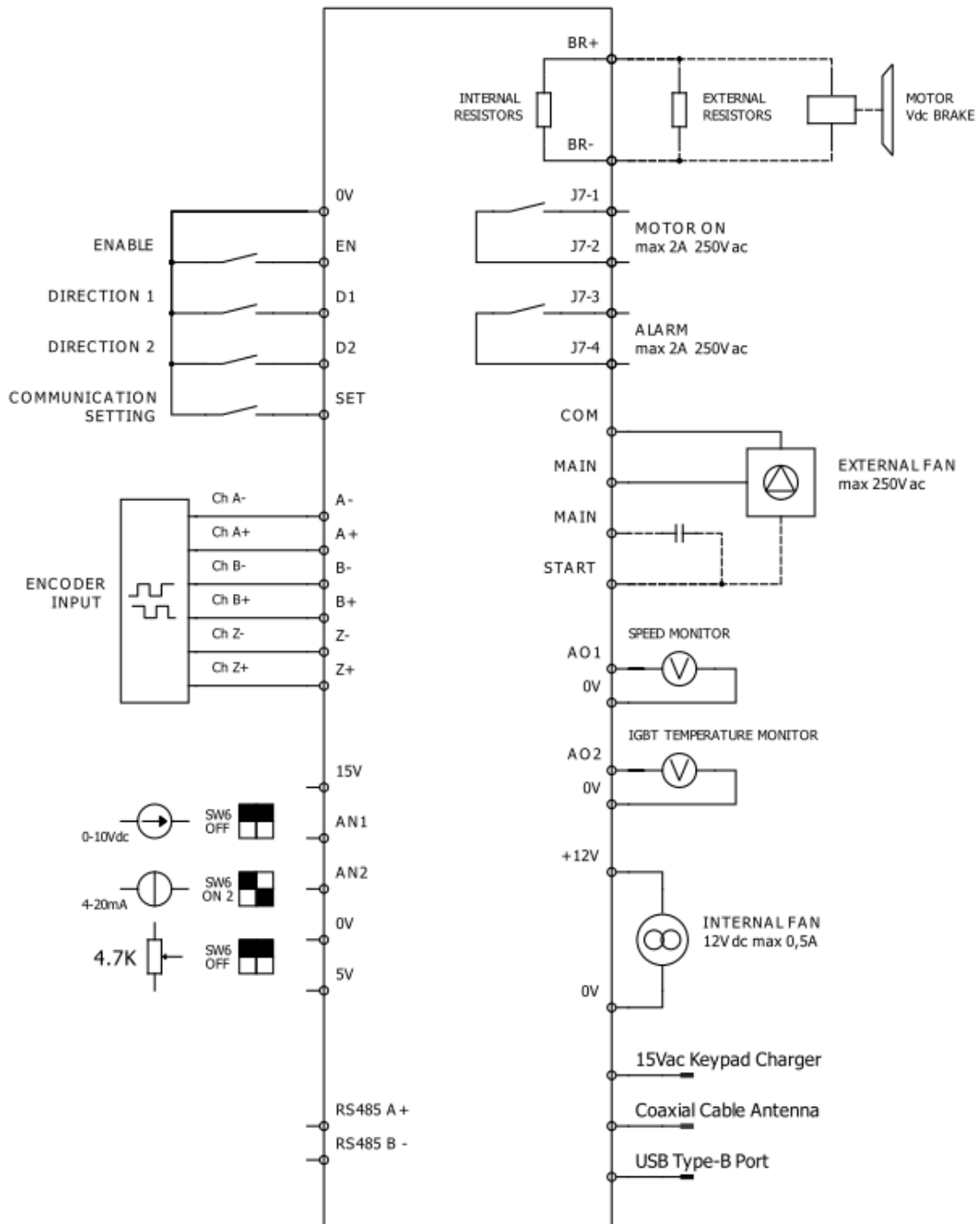
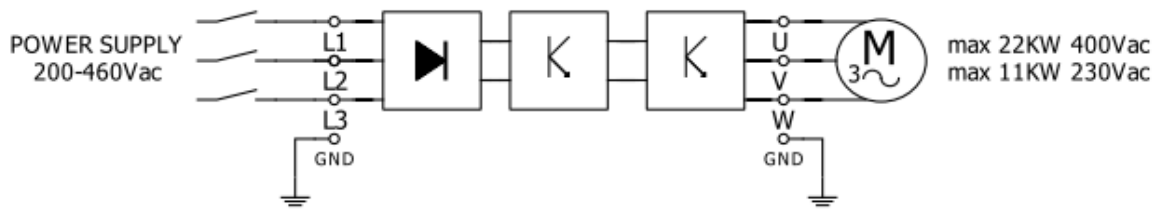

5c. The 87Hz technique

It is possible to achieve special configurations with constant torque up to 87Hz with 230/400V motors.

In a normal installation, the motor driven at a frequency lower than the rated, for example 20 Hz, will automatically have at the terminals of the windings a voltage lower than the rated one. As the frequency increases, the voltage increases to maintain the torque. Upon achieving 50 Hz we will also have achieved the rated voltage; at this point there will not be room to increase the output voltage of the inverter.

So, for example at 75 Hz we would need (to maintain the same torque present in 50Hz) a higher voltage than the line voltage, but this cannot be done, and so what happens over 50 Hz is that there is a switch from constant torque driving to constant power driving (graph.1), with the torque decreasing at the same rate the speed increases. **But there is a way to increase the speed beyond the rated speed and at the same time keeping the rated torque constant too** (graph.2): to NOT connect a motor 230V Δ /400VY in a star connection (Ill. 9), as would seem logical, but in a triangle connection (Ill. 10), and to program NEO-WiFi "motor data" for 230V motor, and the current written in the nameplate at 230V (=current at 400V * 1,74).

This way, going over 50 Hz, I still have margin to increase the voltage in proportion to the frequency.

Up to what frequency can I have a constant torque without overloading the motor? Having a linear V/Hz (Volt over Hertz) parameter, the calculation, for a 230V Δ /400VY 50Hz motor, is: $400/230=1,739$. $1,739 \times 50\text{Hz} = 87\text{Hz}$. The limit within which I can have a constant torque is therefore 87Hz. Therefore the maximum allowable current from the motor is achieved only when in output there is 400 Volts and 87 Hz.

What follows are two calculation examples, which take into account two different voltages and rated frequencies for the motor.

230/400V 50Hz motor

$$400/230= 1.739$$

$$1,739*50\text{Hz}= 87 \text{ Hz} \quad \text{maximum frequency with constant torque}$$

220/380V 60Hz motor

$$380/220= 1.727$$

$$1,727*60\text{Hz}= 104 \text{ Hz} \quad \text{maximum frequency with constant torque}$$

So since inverters should not be divided by power (they are classified by power only for practicality and by habit), but by steady current output, if the rated motor current, indicated on the plate at 230V, is less than the rated output current from the Inverter (to the motor) I_{2n} (Ca. "Working conditions") then the 87Hz technique can be used

NEO-WiFi-3kW 400V + mot 100LB-4 3kW 230/400V 50Hz connected  (graph.1)

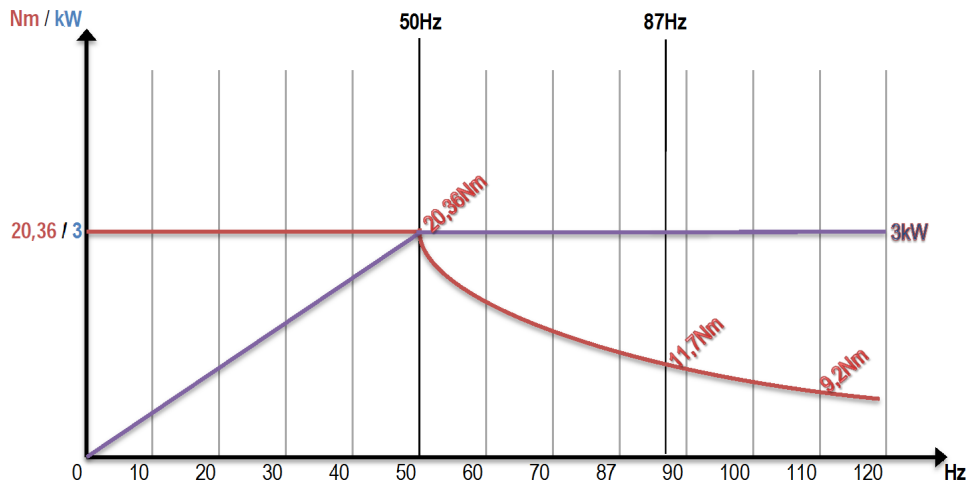

NEO-WiFi 3kW 400V + mot 90L-4 1,5kW 230/400V 50Hz connected  (graph.2)

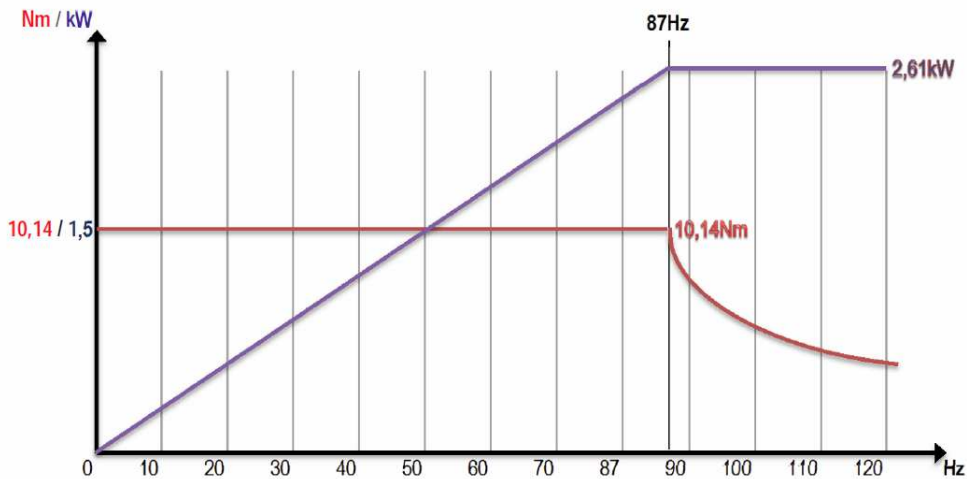

*** Of course, a VFD will have torque pulsation issues at frequencies lower than about 6 Hz, but this does not affect its starting torque**

5d. Connection of the external devices

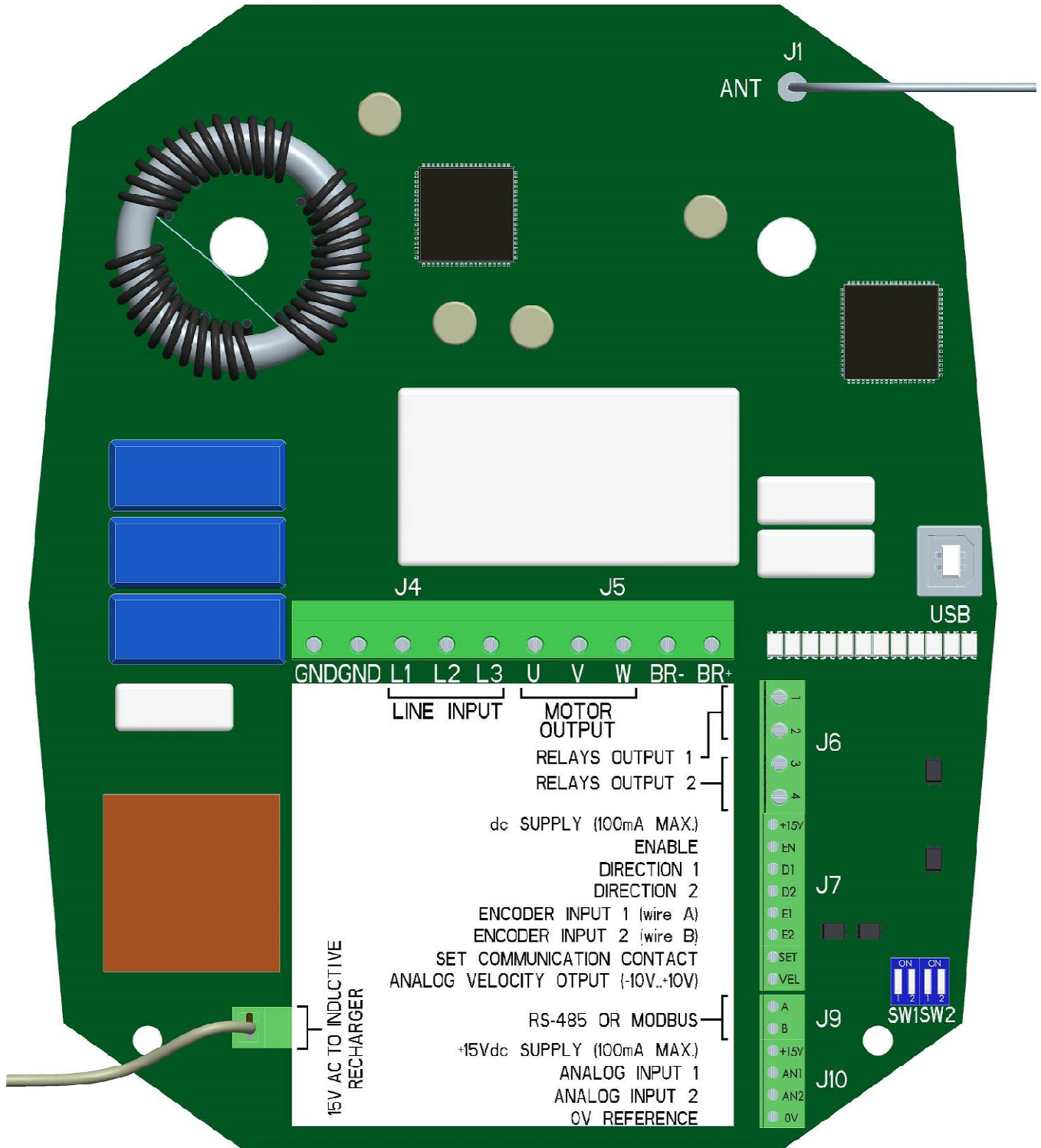

Illustration 13 – power and control module - NEO-WiFi-3

NEO-WiFi-3

Pin	Terminal	Function
1	J6	MOTOR ON- normally open contact that closes when the motor starts It is possible to connect to external devices 5 Ampere max, 250Vac max
2		
3		TEMP- normally open contact that closes when the IGBT bridge temperature exceeds 50°C It is possible to connect to external devices 5 Ampere max, 250Vac max
4		ALARM – normally open contact that closes when there is an alarm, simultaneously shown on the keypad display. It is possible to connect to external devices 5 Ampere max, 250Vac max.
+15V	J7	15Vdc output (max 100mA)
EN		enables/disables the inverter operation (NOTE: do not connect it to 24Vdc)
D1		direction 1 (rotation sense 1 of motor)
D2		direction 2 (rotation sense 2 of motor)
E1		encoder or proximity sensor input (Channel A)
E2		encoder or proximity sensor input (Channel B)
SET		communication channel selection (closing this contact with 15V)
VEL		analogue output 1 (-10V...+10V) proportional to the motor speed between Vmin (0V) and Vmax (10V), with + sign for direction 1 and - sign for direction 2
A		J9
B		
+15V	J10	15Vdc output (max 100mA)
AN1		analogue input 1 (external signal for speed 0-10Vdc / 4-20mA) (from keypad version 2.05, also 4-20mA → read advanced functions menu)
AN2		analogue input 2 (external potentiometer)
0V		0Vdc
GND	J4	ground
L1		phase 1 for inverter power supply from net
L2		phase 2 for inverter power supply from net
L3		phase 3 for inverter power supply from net
U	J5	U phase motor connection
V		V phase motor connection
W		W phase motor connection
BR-		internal braking resistances connection (opt. External), or motor dc brake connection
BR+		
USB		PC connection for diagnostics
SW1		Via the 2 dips in ON position there's a 4-20mA configuration, in OFF position there's a 0-10V configuration (SW1 for AN1 and SW2 for AN2)
SW2		
15Vac		15Vac HF output for induction recharger

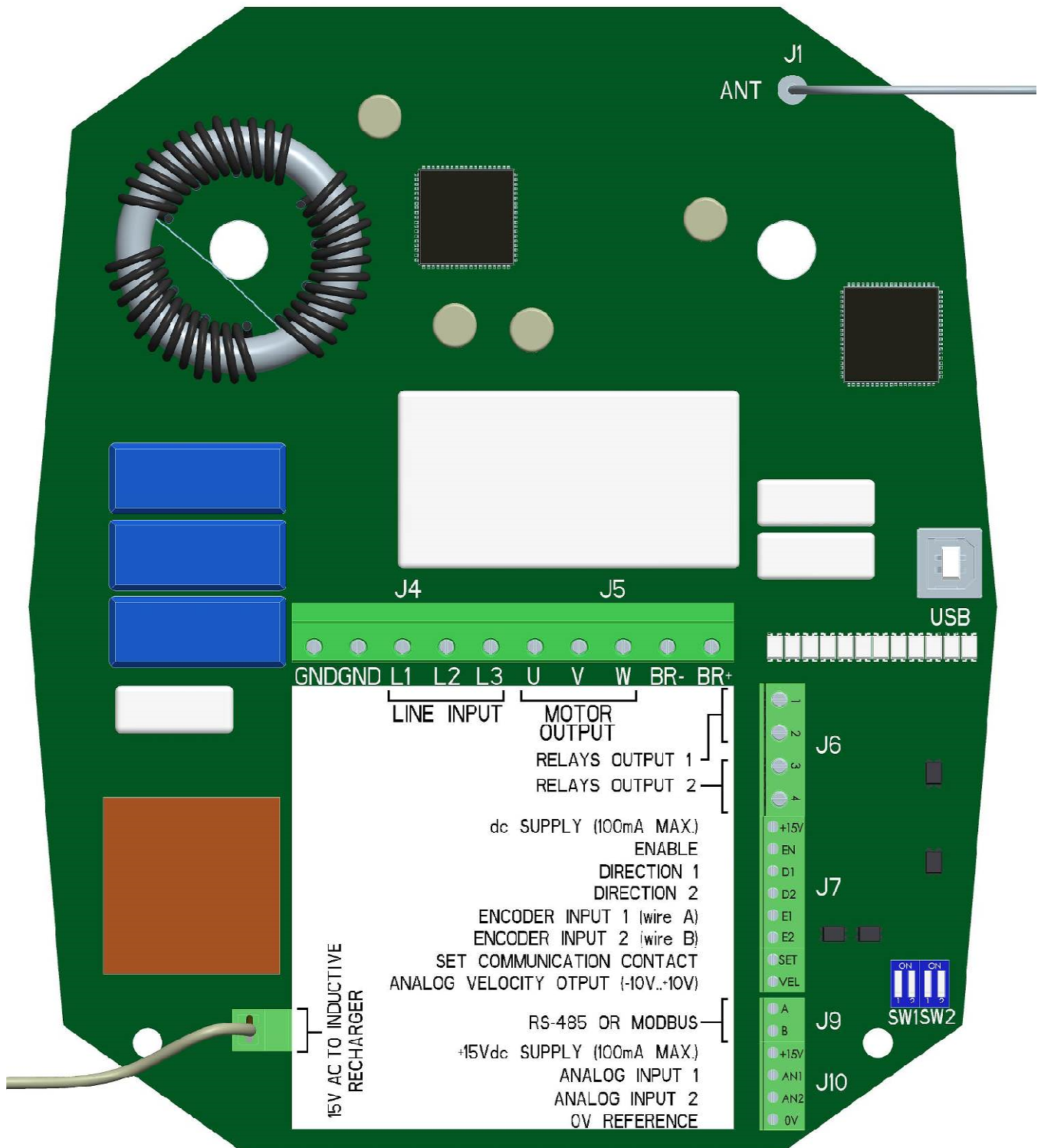

Illustration 13 (4) – power and control module - [NEO-WiFi-4](#)

NEO-WiFi-4

Pin	Terminal	Function	
1	J6	MOTOR ON- normally open contact that closes when the motor starts It is possible to connect to external devices 5 Ampere max, 250Vac max	
2		TEMP- normally open contact that closes when the IGBT bridge temperature exceeds 50°C It is possible to connect to external devices 5 Ampere max, 250Vac max ALARM - normally open contact that closes when there is an alarm, simultaneously shown on the keypad display. It is possible to connect to external devices 5 Ampere max, 250Vac max.	
3			
4			
+15V	J7	15Vdc output (max 100mA)	
EN		enables/disables the inverter operation (NOTE: do not connect it to 24Vdc)	
D1		direction 1 (rotation sense 1 of motor)	
D2		direction 2 (rotation sense 2 of motor)	
E1		encoder or proximity sensor input (Channel A)	
E2		encoder or proximity sensor input (Channel B)	
SET		communication channel selection (closing this contact with 15V)	
VEL		analogue output 1 (-10V...+10V) proportional to the motor speed between Vmin (0V) and Vmax (10V), with + sign for direction 1 and - sign for direction 2	
A		J9	RS485 (for Master-Slave connection) or Modbus (activated from March 2014)
B			
+15V	J10	15Vdc output (max 100mA)	
AN1		analogue input 1 (external signal for speed 0-10Vdc / 4-20mA) (from keypad version 2.05, also 4-20mA → read advanced functions menu)	
AN2		analogue input 2 (external potentiometer)	
0V		0Vdc	
GND	J4	ground	
L1		phase 1 for inverter power supply from net	
L2		phase 2 for inverter power supply from net	
L3		phase 3 for inverter power supply from net	
U	J5	U phase motor connection	
V		V phase motor connection	
W		W phase motor connection	
BR-		internal braking resistances connection (opt. External), or motor dc brake connection	
BR+			
USB		PC connection for diagnostics	
SW1		Via the 2 dips in ON position there's a 4-20mA configuration, in OFF position there's a 0-10V configuration (SW1 for AN1 and SW2 for AN2)	
SW2			
15Vac		15Vac HF output for induction recharger	

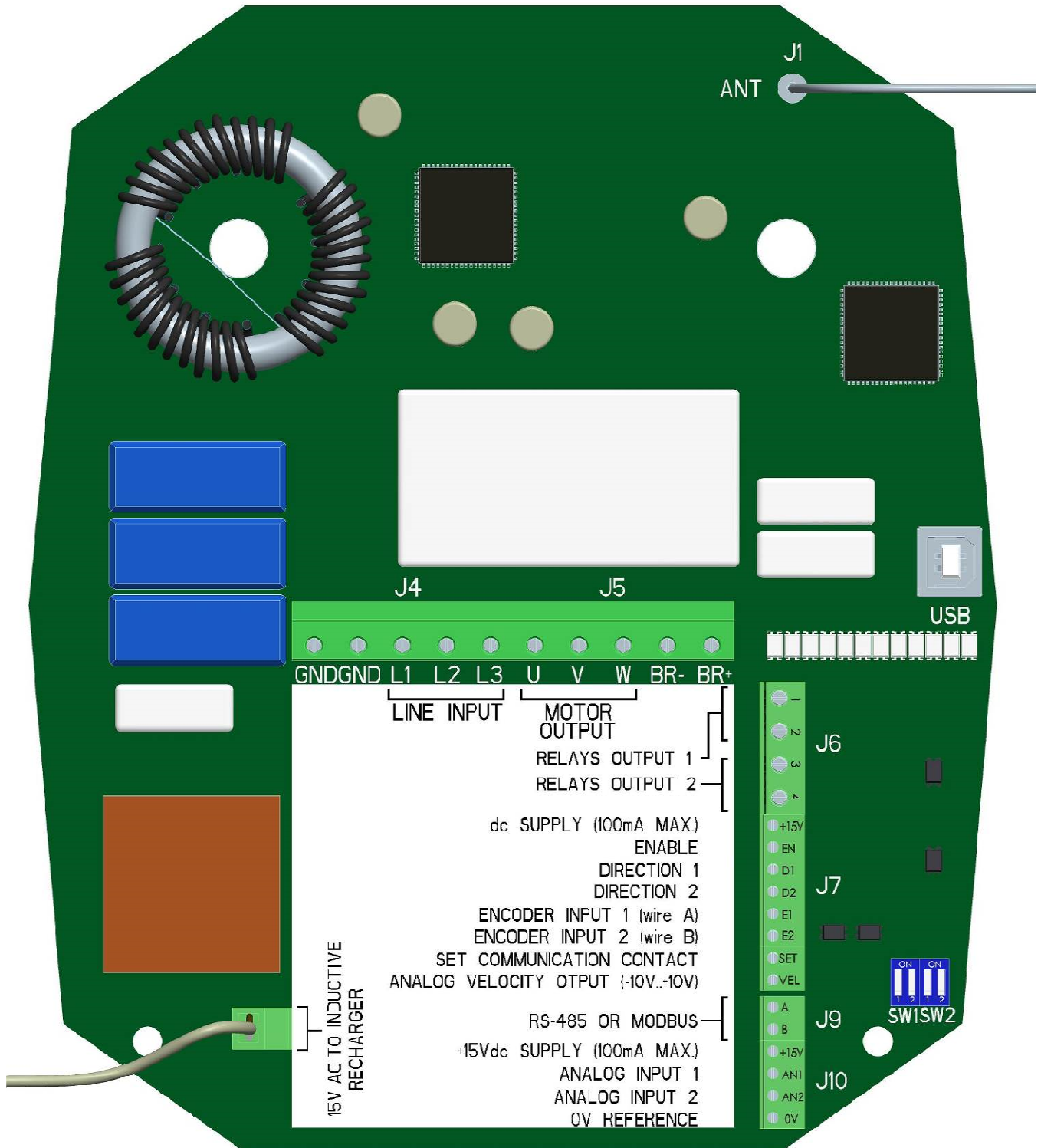

Illustration 13 (5.5) – power and control module - [NEO-WiFi-5.5](#)

NEO-WiFi-5.5

Pin	Terminal	Function
1	J6	MOTOR ON- normally open contact that closes when the motor starts It is possible to connect to external devices 5 Ampere max, 250Vac max
2		TEMP- normally open contact that closes when the IGBT bridge temperature exceeds 50°C It is possible to connect to external devices 5 Ampere max, 250Vac max ALARM - normally open contact that closes when there is an alarm, simultaneously shown on the keypad display. It is possible to connect to external devices 5 Ampere max, 250Vac max.
3		
4		
+15V	J7	15Vdc output (max 100mA)
EN		enables/disables the inverter operation (NOTE: do not connect it to 24Vdc)
D1		direction 1 (rotation sense 1 of motor)
D2		direction 2 (rotation sense 2 of motor)
E1		encoder or proximity sensor input (Channel A)
E2		encoder or proximity sensor input (Channel B)
SET		communication channel selection (closing this contact with 15V)
VEL		analogue output 1 (-10V...+10V) proportional to the motor speed between Vmin (0V) and Vmax (10V), with + sign for direction 1 and - sign for direction 2
A		J9
B		
+15V	J10	15Vdc output (max 100mA)
AN1		analogue input 1 (external signal for speed 0-10Vdc / 4-20mA) (from keypad version 2.05, also 4-20mA → read advanced functions menu)
AN2		analogue input 2 (external potentiometer)
0V		0Vdc
GND	J4	ground
L1		phase 1 for inverter power supply from net
L2		phase 2 for inverter power supply from net
L3		phase 3 for inverter power supply from net
U	J5	U phase motor connection
V		V phase motor connection
W		W phase motor connection
BR-		internal braking resistances connection (opt. External), or motor dc brake connection
BR+		
USB		PC connection for diagnostics
SW1		Via the 2 dips in ON position there's a 4-20mA configuration, in OFF position there's a 0-10V configuration (SW1 for AN1 and SW2 for AN2)
SW2		
15Vac		15Vac HF output for induction recharger

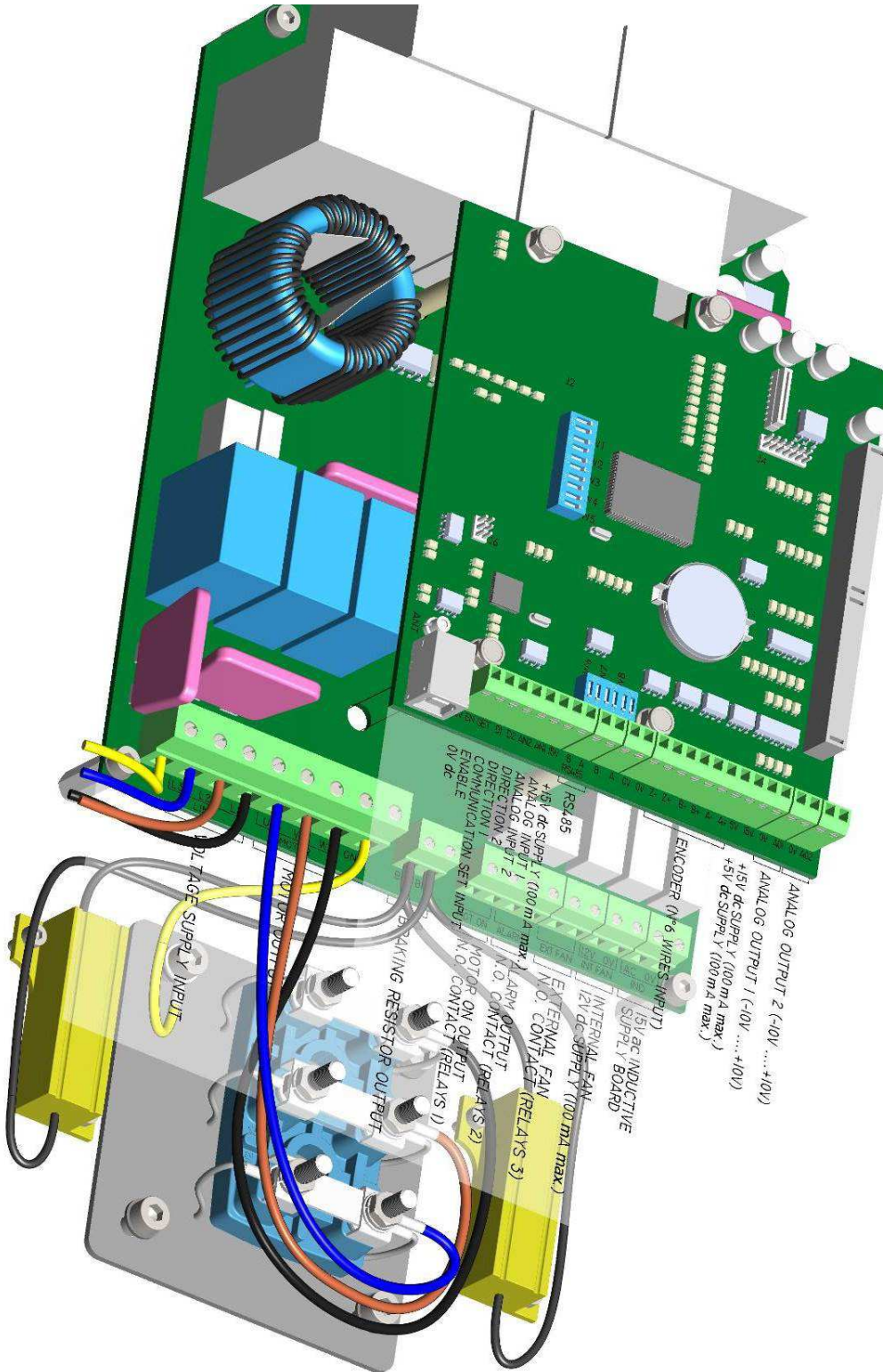
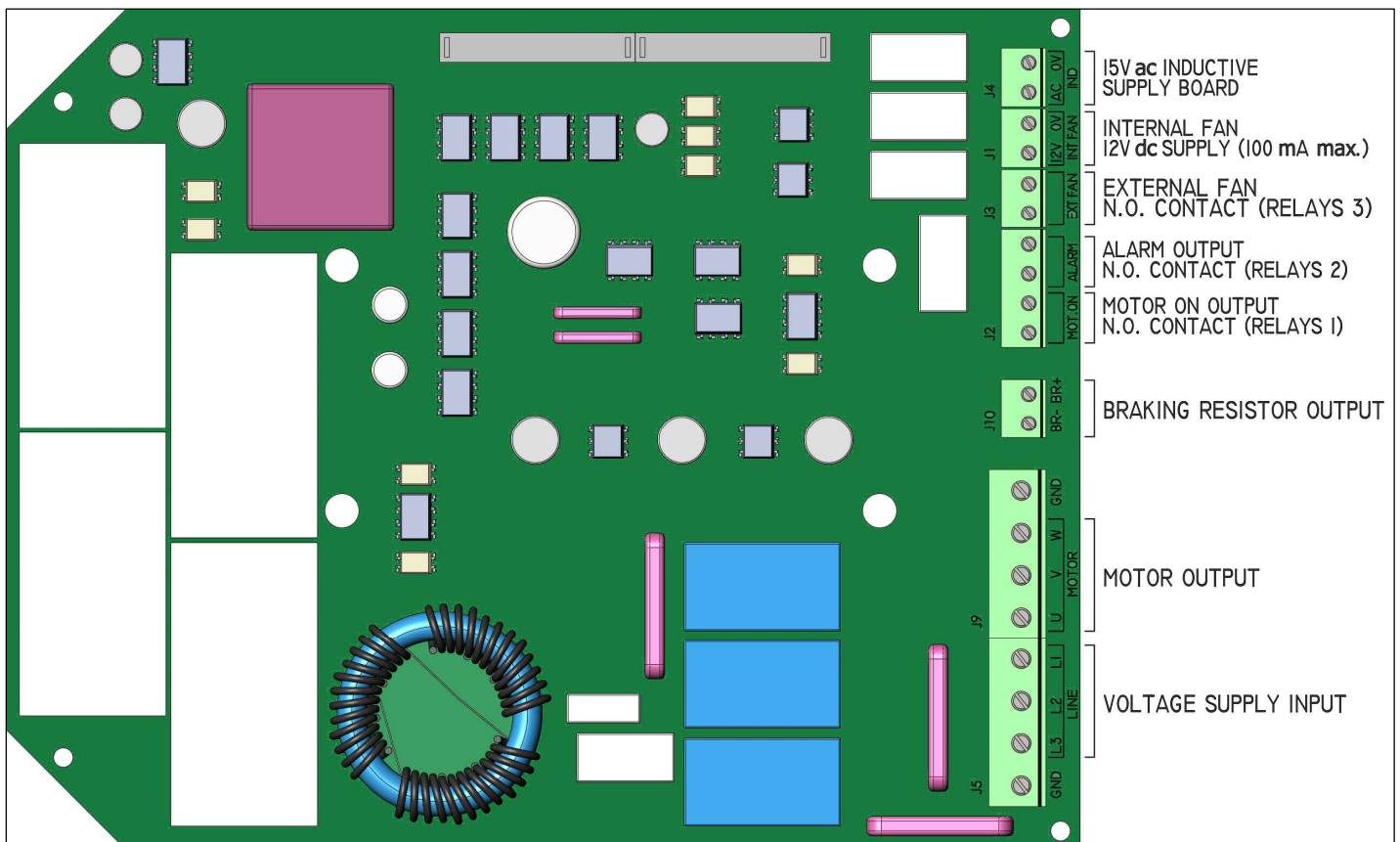
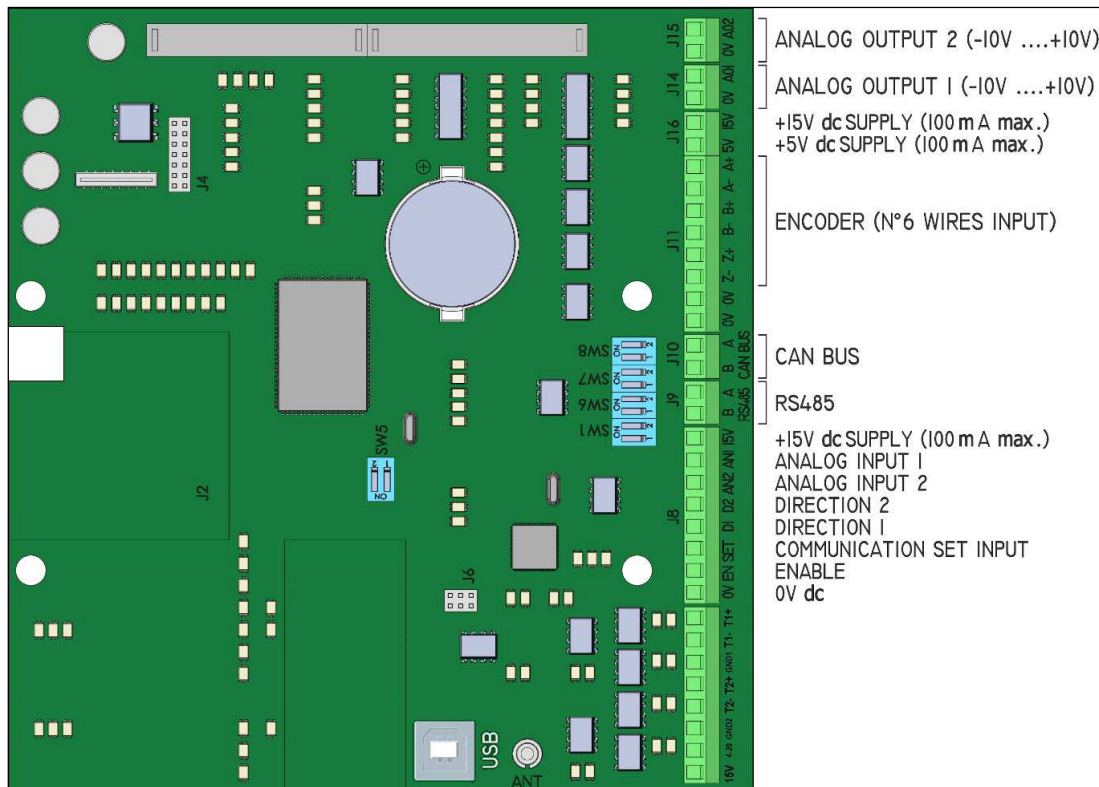

Illustration 13 (11) - power and control modules - [NEO-WiFi-11](#)



NEO-WiFi-11 (control module)

Pin	Terminal	Function
AO2	J15	analogue output 2 (0...+10V) for internal IGBT temperature signal (0...100°C). Activated from V1.06
0V		
AO1	J14	analogue output 1 (-10V...+10V) for motor speed signal (absolute value) and rotation sense (+ sign for sense 1 and - sign for sense 2)
0V		
15V	J16	15Vdc output (max 100mA)
5V		5Vdc output (max 100mA)
A+	J11	channel A+ input
A-		channel A- input
B+		channel B+ input
B-		channel B- input
Z+		channel Z+ input
Z-		channel Z- input
0V		ground
0V		ground
A	J10	Modbus communication gate (activated from March 2014)
B		
A	J9	RS485 Bus, (for Master-Slave group connection)
B		
15V	J8	15Vdc output
AN1		analogue input 1 (external signal for speed 0-10Vdc / 4-20mA) (from keypad version 2.05, also 4-20mA → read advanced functions menu)
AN2		analogue input 2 (external potentiometer)
D2		direction 2 (rotation sense 2 motor with external controls)
D1		direction 1 (rotation sense 1 motor with external controls)
SET		communication channel selection (closing this contact with 0V)
EN		enables the motor operation (closing this contact with 0V) (NOTE: do not connect it to 24Vdc)
0V		0Vdc
USB		PC connection for diagnostics
SW5		not activated
SW1		dip 2 (OFF input AN1 in voltage 0-10V; ON input AN1 in current 4-20mA) dip 1 (OFF input AN2 in voltage 0-10V; ON input AN2 in current 4-20mA)
SW6		dip 2 (OFF input AN1 in voltage 0-10V; ON input AN1 in current 4-20mA) dip 1 (OFF input AN2 in voltage 0-10V; ON input AN2 in current 4-20mA)
SW7		Dip 1 and 2 ON for the RS485 load resistors (only for the first and the last of the NEOs in group - putting ON the same dips in the NEOs in the middle there is risk of transmission failure)
SW8		not activated

NEO-WiFi-11 (power module)

Pin	Terminal	Function
0V IND	J4	15Vac HF output for induction recharger
AC IND		
0V DC FAN	J1	12Vdc output for internal cooling fan (it closes when the IGBT temperature exceeds 45°C, and re-opens when it returns <40°C)
12V DC FAN		
EXT FAN	J3	normally open contact that closes when the IGBT bridge temperature exceeds 45°C, in order to enable the start of an eventual optional external fan
EXT FAN		
ALARM	J2	normally open contact that closes when there is an alarm, simultaneously shown on the keypad display. It is possible to connect to external devices 5 Ampere max, 250Vac max
ALARM		
MOT ON		normally open contact that closes when the motor starts. It is possible to connect to external devices 5 Ampere max, 250Vac max
MOT ON		
BR+	J10	internal braking resistances connection (opt. External), or motor dc brake connection
BR-		
GND	J9	ground
U		W phase motor connection
V		V phase motor connection
W		U phase motor connection
L3	J5	phase 1 for inverter power supply from net
L2		phase 2 for inverter power supply from net
L1		phase 3 for inverter power supply from net
GND		ground

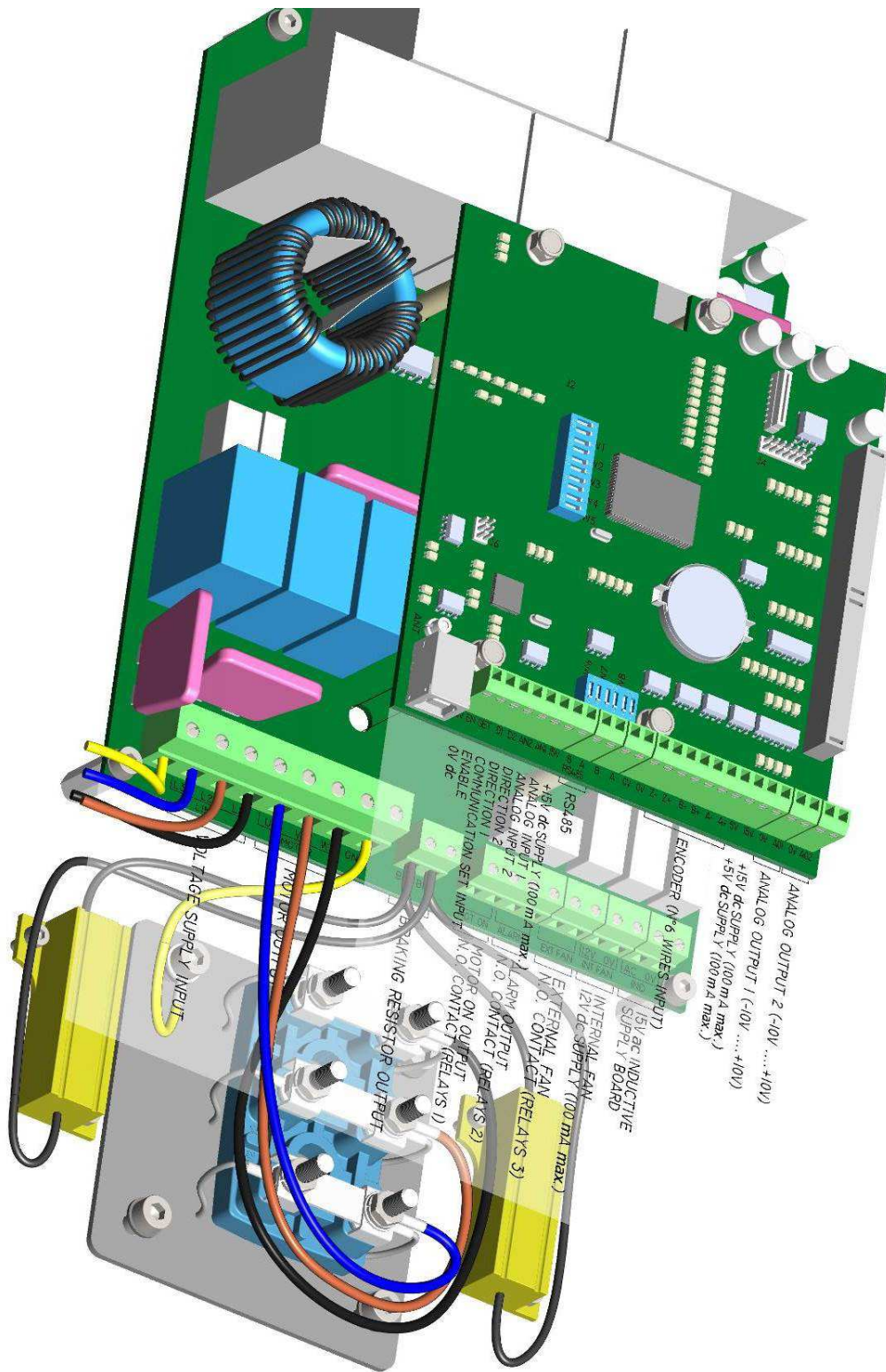
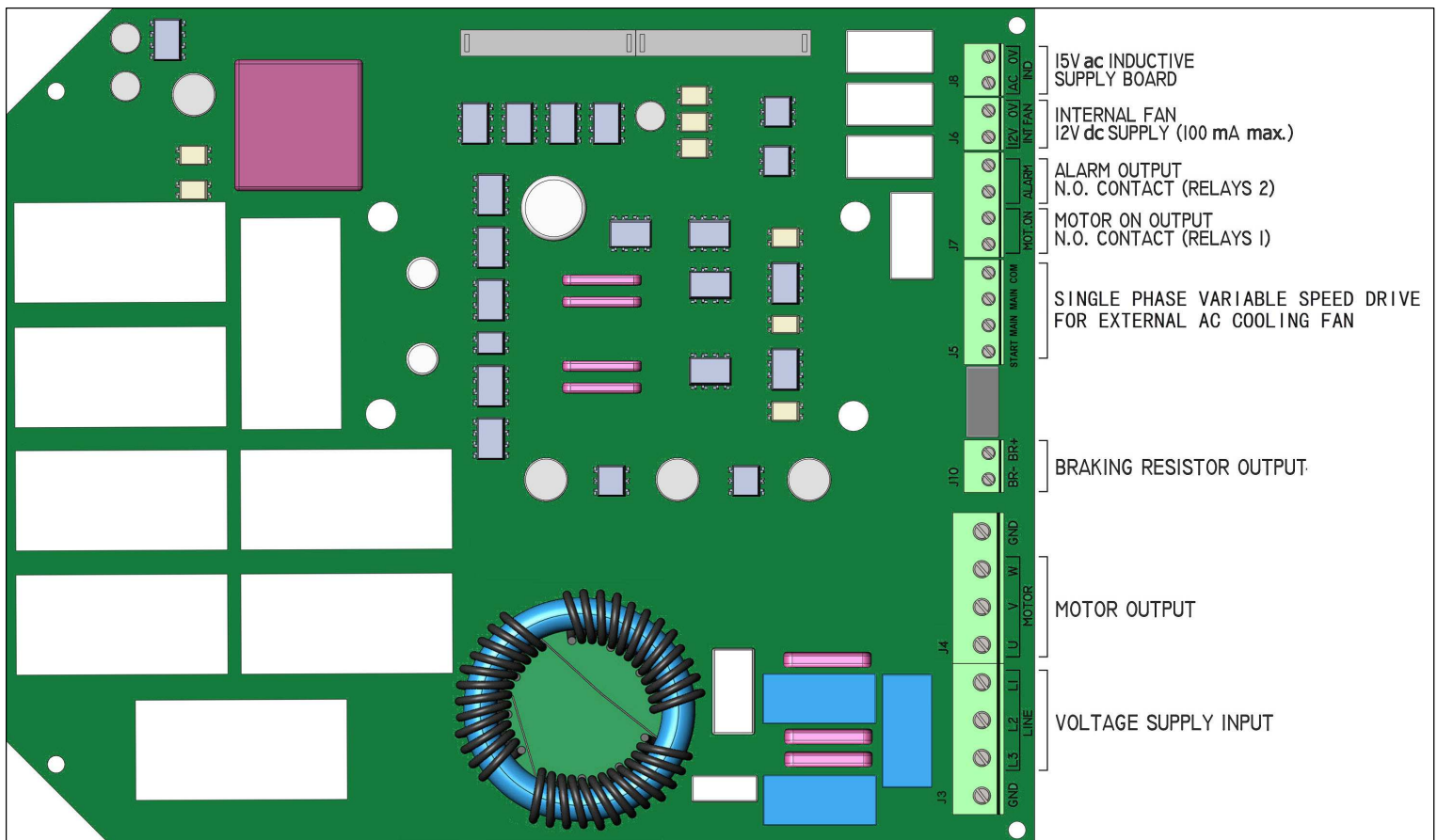
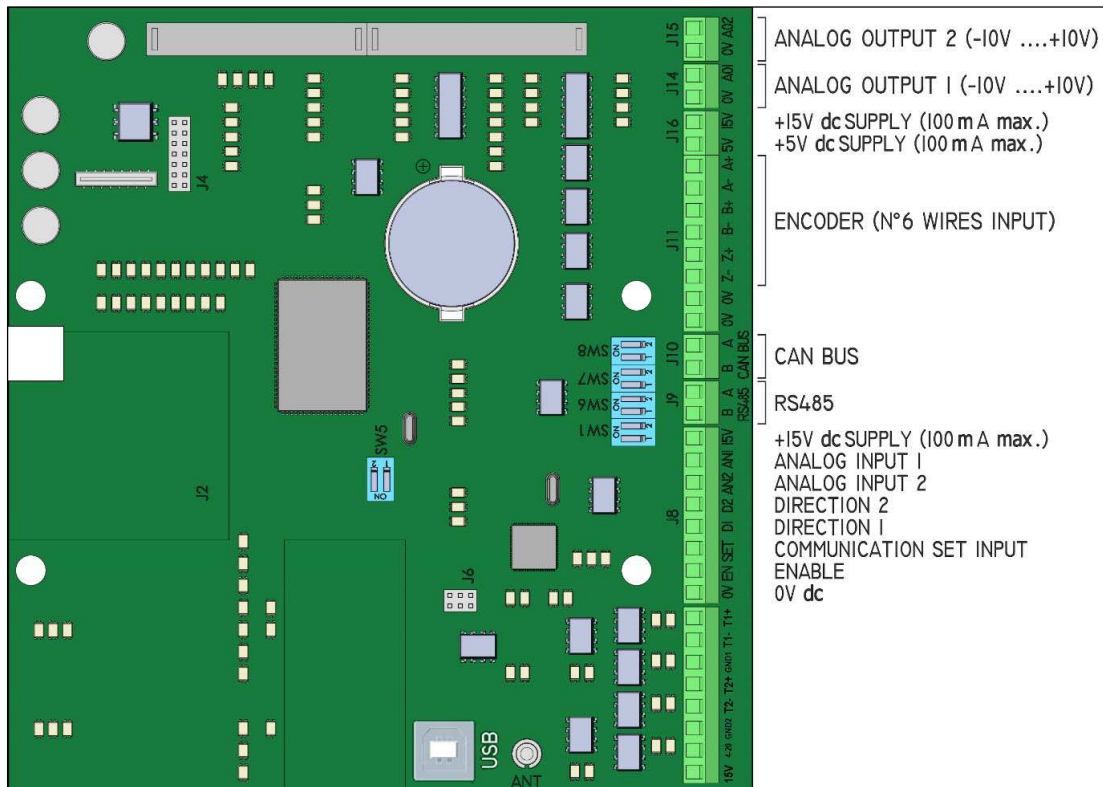

Illustration 13 (12) – power and control modules - NEO-WiFi-22



NEO-WiFi-22 (control module)

Pin	Terminal	Function
AO2	J15	analogue output 2 (0...+10V) for internal IGBT temperature signal (0...100°C). Activated from V1.06
0V		
AO1	J14	analogue output 1 (-10V...+10V) for motor speed signal (absolute value) and rotation sense (+ sign for sense 1 and - sign for sense 2)
0V		
15V	J16	15Vdc output (max 100mA)
5V		5Vdc output (max 100mA)
A+	J11	channel A+ input
A-		channel A- input
B+		channel B+ input
B-		channel B- input
Z+		channel Z+ input
Z-		channel Z- input
0V		ground
0V		ground
A	J10	Modbus communication gate (activated from March 2014)
B		
A	J9	RS485 Bus, (for Master-Slave group connection)
B		
15V	J8	15Vdc output
AN1		analogue input 1 (external signal for speed 0-10Vdc / 4-20mA) (from keypad version 2.05, also 4-20mA → read advanced functions menu)
AN2		analogue input 2 (external potentiometer)
D2		direction 2 (rotation sense 2 motor with external controls)
D1		direction 1 (rotation sense 1 motor with external controls)
SET		communication channel selection (closing this contact with 0V)
EN		enables the motor operation (closing this contact with 0V) (NOTE: do not connect it to 24Vdc)
0V		0Vdc
USB		PC connection for diagnostics
SW5		not activated
SW1		dip 2 (OFF input AN1 in voltage 0-10V; ON input AN1 in current 4-20mA) dip 1 (OFF input AN2 in voltage 0-10V; ON input AN2 in current 4-20mA)
SW6		dip 2 (OFF input AN1 in voltage 0-10V; ON input AN1 in current 4-20mA) dip 1 (OFF input AN2 in voltage 0-10V; ON input AN2 in current 4-20mA)
SW7		Dip 1 and 2 ON for the RS485 load resistors (only for the first and the last of the NEOs in group - putting ON the same dips in the NEOs in the middle there is risk of transmission failure)
SW8		not activated

NEO-WiFi-22 (power module)

AC IND	J8	15Vac HF output for induction recharger
0V IND		
12V DC FAN	J6	12Vdc output for internal cooling fan (it closes when the IGBT temperature exceeds 45°C)
0V DC FAN		
ALARM	J7	normally open contact that closes when there is an alarm, simultaneously shown on the keypad display. It is possible to connect to external devices 5 Ampere max, 250Vac max
ALARM		
MOTOR ON		relay normally open contact that closes when the motor starts. It is possible to connect to external devices 5 Ampere max, 250Vac max
MOTOR ON		
COM	J5	power supply for eventual induction single/three phase cooling fans
MAIN		
MAIN		
START		
BR+	J11	internal braking resistances connection (opt. External), or motor dc brake connection
BR-		
GND	J4	ground
W		W phase motor connection
V		V phase motor connection
U		U phase motor connection
L1	J3	phase 1 for inverter power supply from net
L2		phase 2 for inverter power supply from net
L3		phase 3 for inverter power supply from net
GND		ground

5d.1. Examples

- To manage the stop and the direction of rotation, it is also possible to connect other auxiliary analogic commands, for example micro switch outputs or PLC, among the +15V-D1-D2 / 0V-D1-D2 contacts.
- Example: 3-position switch (1 – 0 – 2) among the +15V-D1-D2 / 0V-D1-D2 contacts of the power board (III. COM1).

III. (3) COM1 - NEO-WiFi-3 - NEO-WiFi-4 - NEO-WiFi-5.5

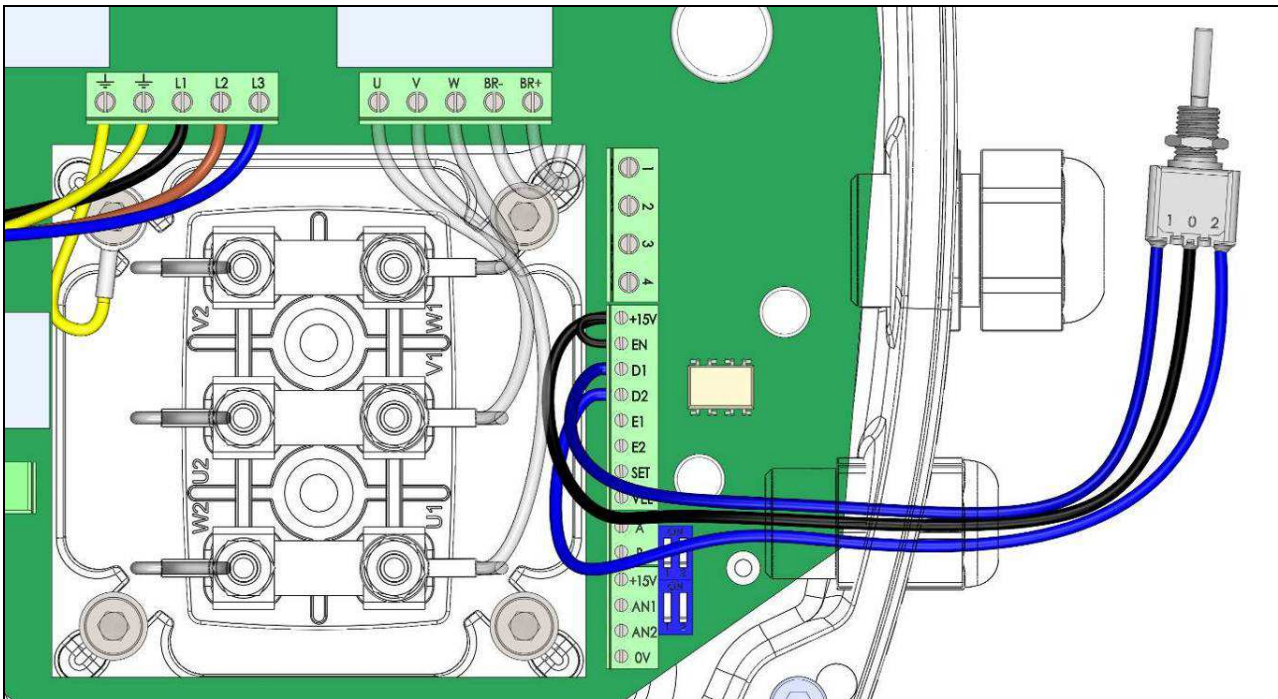

III. (11) COM1 - NEO-WiFi-11 - NEO-WiFi-22

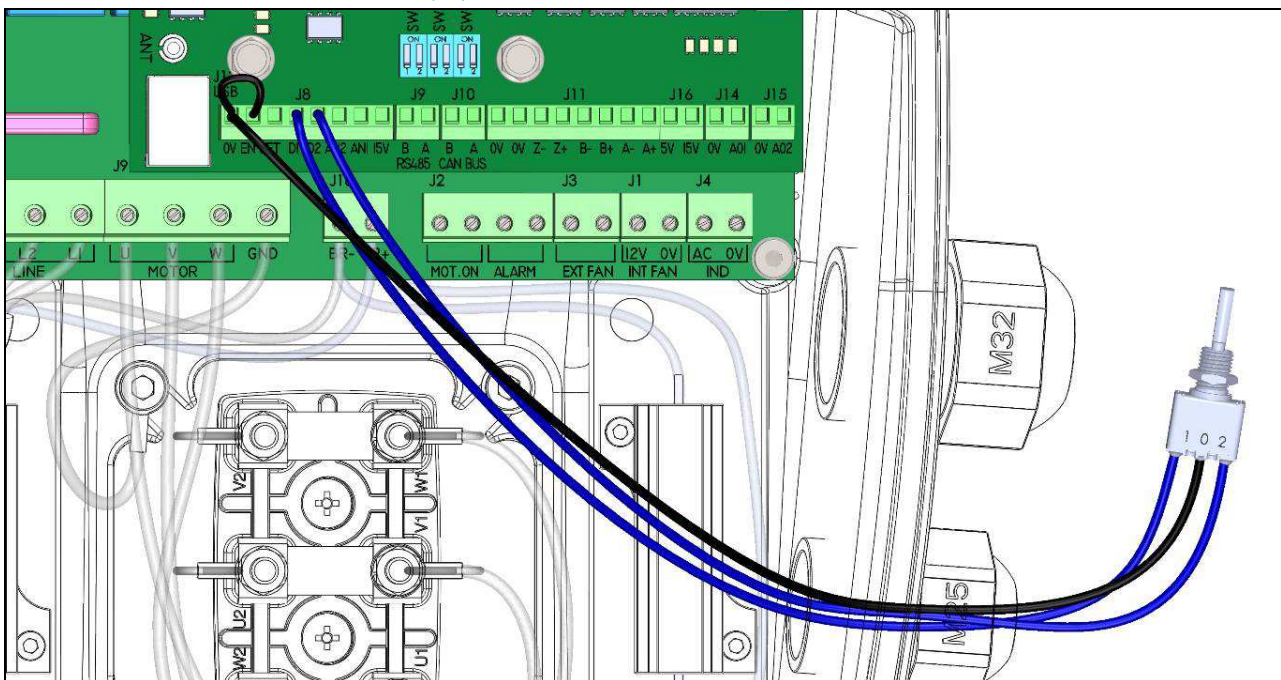

If necessary connect an external enabling contact (Fig. COM2) this same must be connected between the +15V- EN / 0V-EN terminals (ON enabled with closed contact) after removal of the jumper on the same terminals;

III. (3) COM2 - NEO-WiFi-3 - NEO-WiFi-4 - NEO-WiFi-5.5

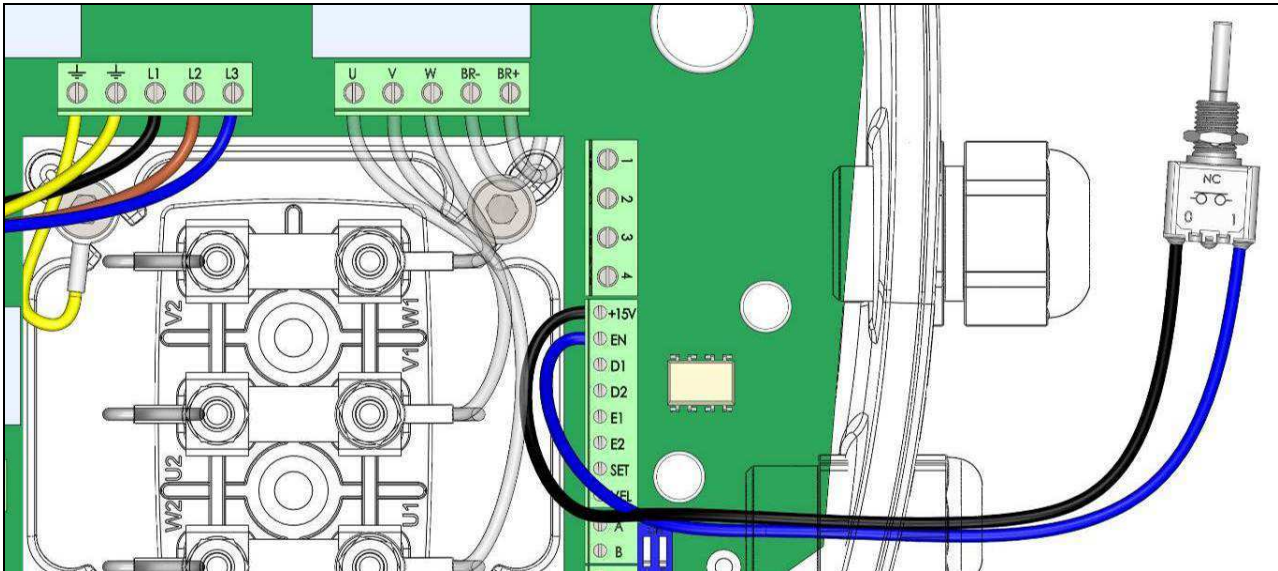

III. (11) COM2 - NEO-WiFi-11 - NEO-WiFi-22

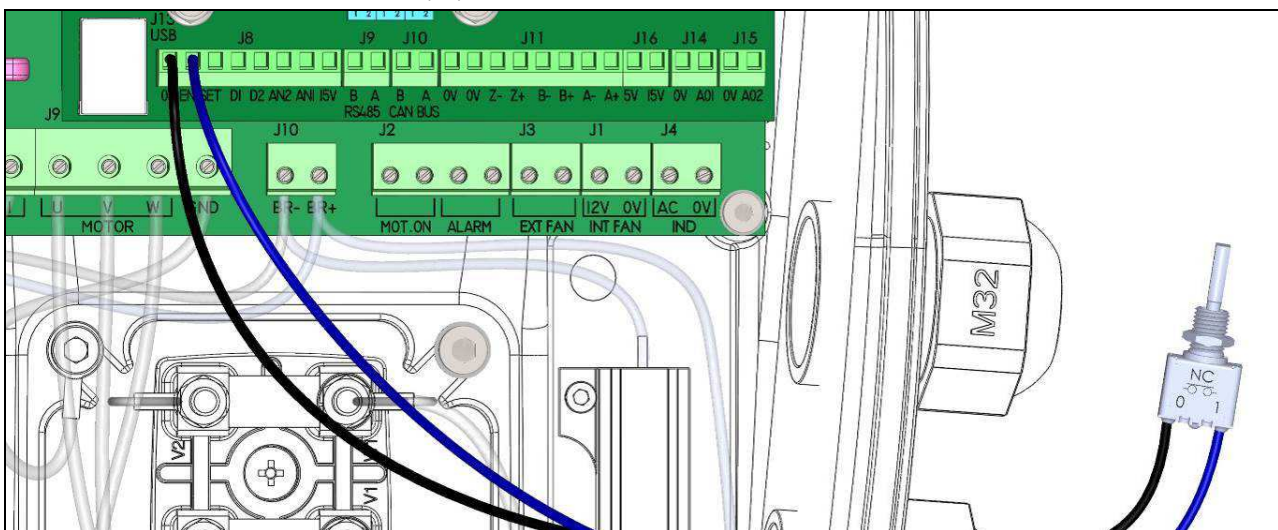

NEO-WIFI-3 - NEO-WIFI-4 - NEO-WIFI-5.5 comes standard with a jumper on +15 V and EN terminals on the terminal box J3 (III. P).
NEO-WIFI-11 - NEO-WIFI-22 comes standard with a jumper on 0 V and EN terminals.

III. P

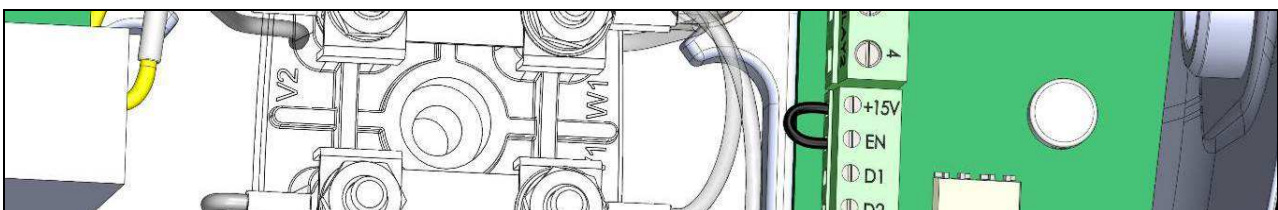

The purpose of this contact is to enable the functioning of NEO-WiFi. Removing it, inhibits the starting of the motor.

- Optional connection: For communication between multiple NEO-WiFis, connect the RS485 serial on the two A and B terminals always respecting the polarity of the connections (A with A and B with B on all inverters NEO-WiFi);
The connection between 2-8 NEO-WiFi with RS485 serial will allow a Master (the inverter that governs the group) type functioning and Slaves (inverters that “copy” the status of the Master: on, speed or off).
NEO-11 and NEO-22: SW7 Dip 1 and 2 ON for the RS485 load resistors (only for the first and the last of the NEOs in group - putting ON the same dips in the NEOs in the middle there is risk of transmission failure)

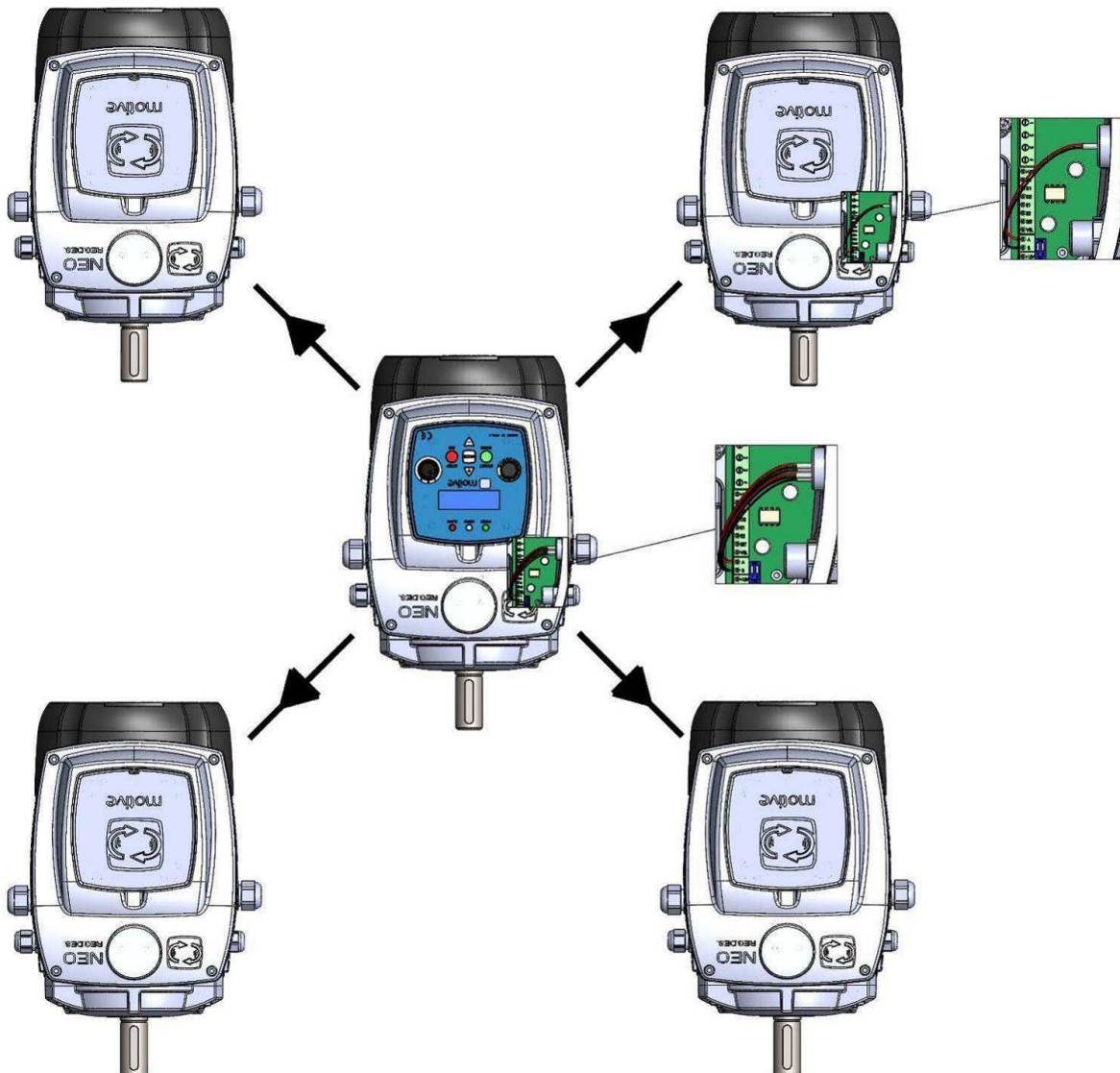

The commands that are copied by the Slaves are: on, off, speed.

Therefore, if for example, the master is a 2-poles motor that rotates at 2800rpm, even a 4-poles slave will go at 2800rpm (the maximum frequency for each slave remains 100Hz, and therefore 2800rpm will be the maximum speed of this slave). To do so, it is obvious that even each individual NEO-WiFi slave must be programmed, to let him know the characteristics of the connected motor. The slaves must have a communication channel that differ from the master. When programming the slave, you can also set acceleration and deceleration ramps that differ from the one of the master, you can connect brake motors even if the master is a motor without brake, etc..

All NEO-WiFi (master and slaves) protection alarms keep working, including those of temperatures.

NOTE: mod-bus control cannot be there with master-slave system work

- Optional connection: To record and analyse events in the lifetime of the device it is possible to connect to a PC with the USB plug that is on the power board, after installing the software on the PC, provided separately;

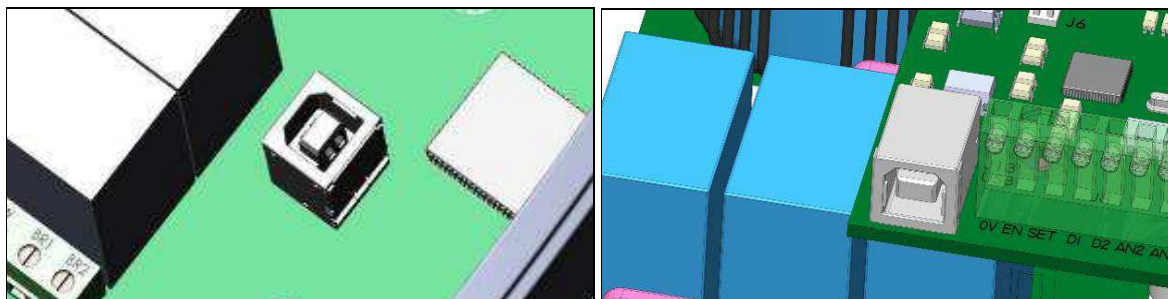

See Chapter 9 “event analysis”



USB: Attention: it must absolutely not be connected with a cable to the PC when the inverter is powered; with NEO-3, there is risk of damage to the USB port of the PC or even worse damage. To be connected only when the inverter is turned off and disconnected from the mains, for diagnostics of recorded alarm events. A label has been affixed to each board that warns of this potential damage to the computer.

• Optional connection:

NEO-WiFi-3 - NEO-WiFi-4 - NEO-WiFi-5.5:

There are two opto-isolated analog inputs AN1 e AN2 (ANALOG INPUT 1, ANALOG INPUT 2) that can be configured:

- Voltage 0-10V (AN1) / external potentiometer (AN2) dip-switches in OFF position (Default)

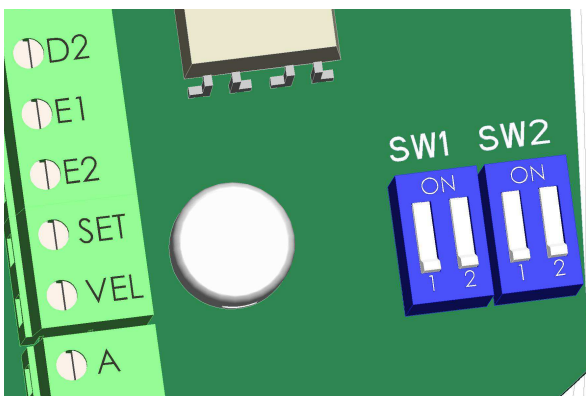

- Current 4-20 mA (AN1/AN2) dip-switches in ON position

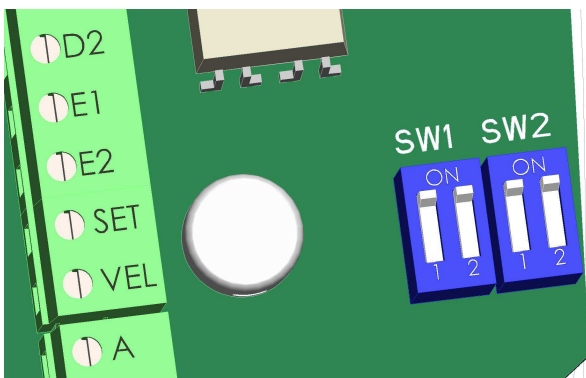

NEO-WiFi-11 - NEO-WiFi-22:

There are two opto-isolated analog inputs AN1 e AN2 (ANALOG INPUT 1, ANALOG INPUT 2) that can be configured:

- Voltage 0-10V (AN1) / external potentiometer (AN2) dip-switches in OFF position (Default)

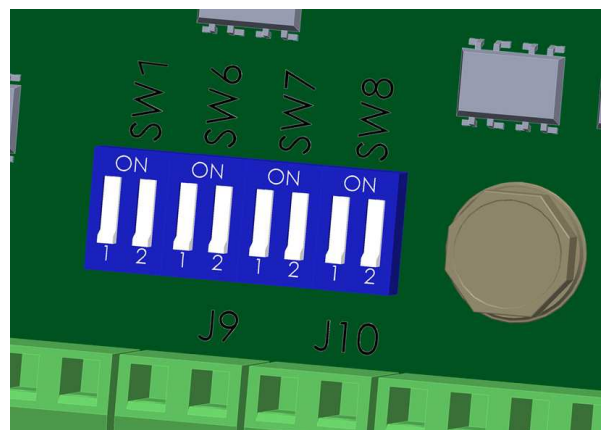

- Current 4-20 mA (AN1\AN2) dip-switches SW1 and SW6 in ON position

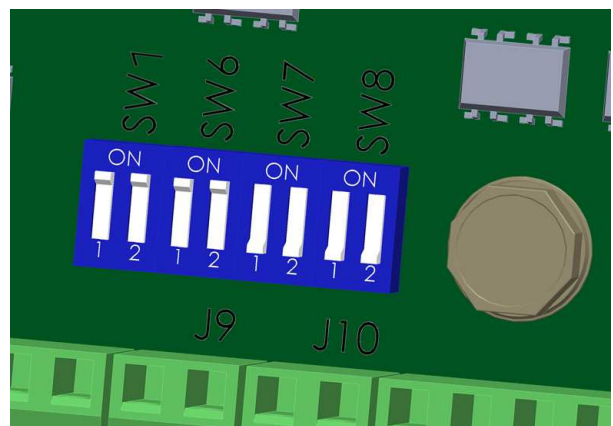

When choosing 0-10V or 4-20mA in AN1, you must also modify the advanced functions menu settings.

Example: temperature sensor connection 0-10V (equivalent connection for pressure transducer). Use the +15V on the terminal block to directly power the probe and use a resistor to create a voltage divider.

NEO-WiFi-11 - NEO-WiFi-22

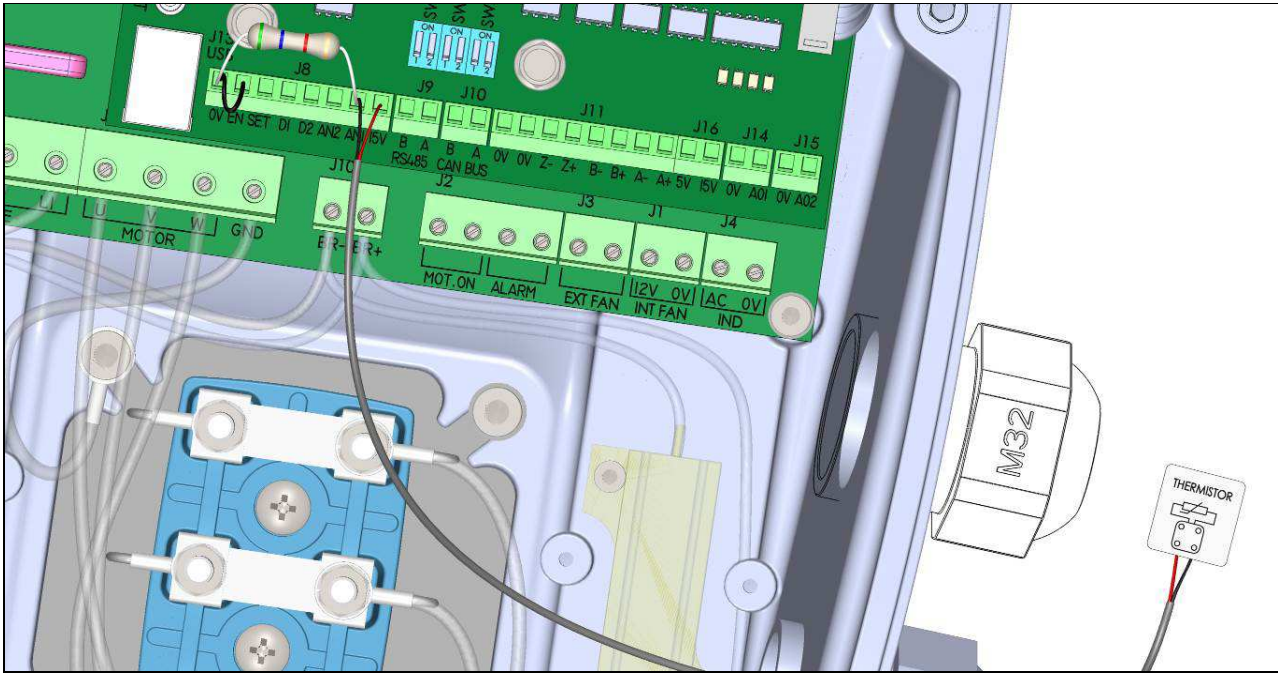

NEO-WiFi-3 - NEO-WiFi-4 - NEO-WiFi-5.5

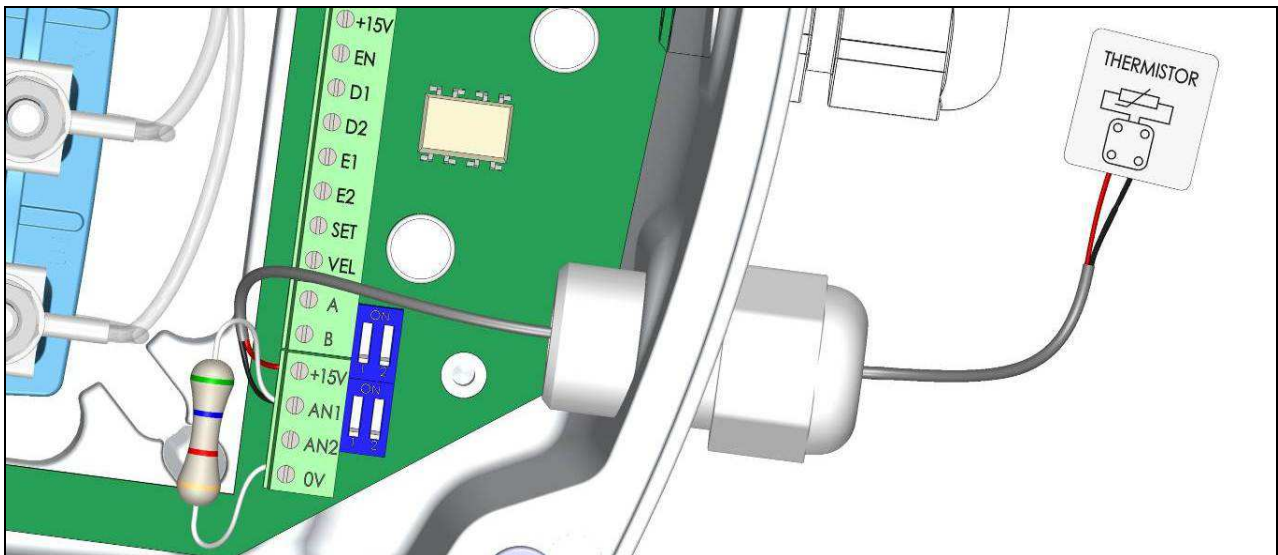

Example: temperature sensor connection 4-20mA (equivalent connection for pressure transducer).

NEO-WiFi-11 - NEO-WiFi-22

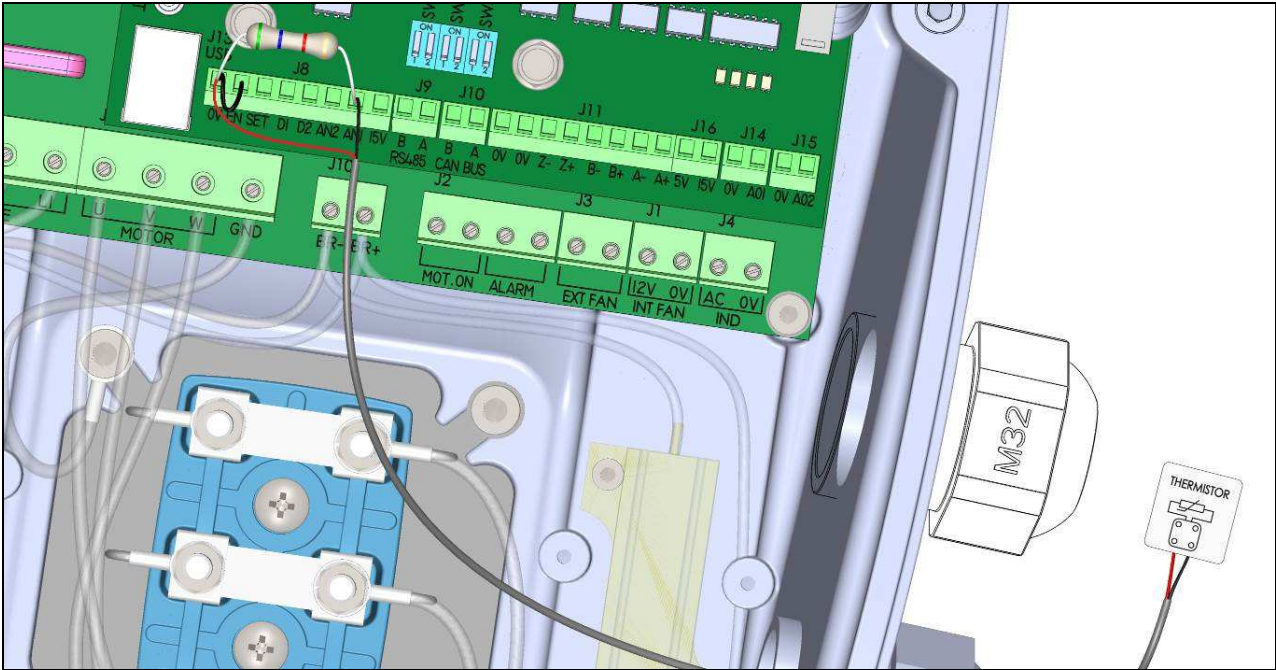

NEO-WiFi-3 - NEO-WiFi-4 - NEO-WiFi-5.5

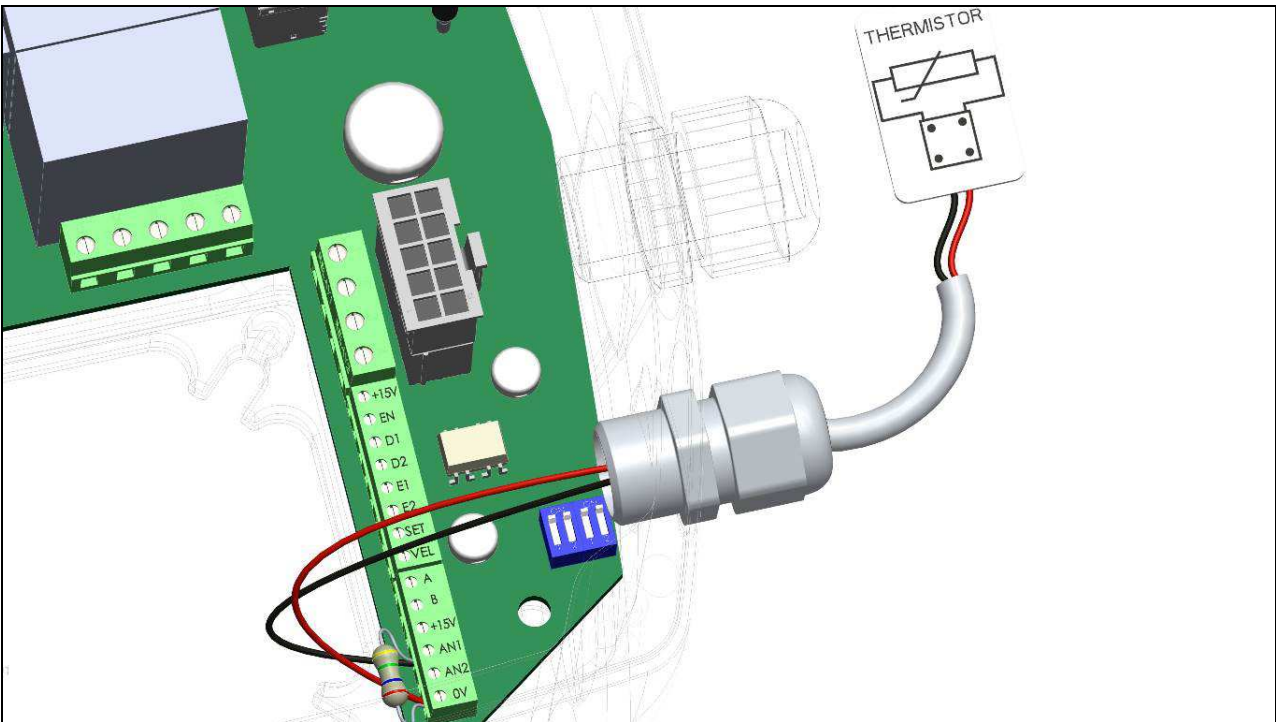

- Optional connection: BRAKE self-braking motor See III. 11 and III. 12.
- Optional connection: ENCODER. III. EN. ENCODER connection Motive-SICK VFS60A-TDPZ0-S01 for speed control in feedback:
 - +Vcc (RED wire) on +15V;
 - -Vcc (BLUE wire) on 0V, with the ground wire
 - Outputs NEO-WiFi-3 :signal A in E1 (WHITE wire); signal B in E2 (PINK wire);
 - Outputs NEO-WiFi-11/22 :signal A_ in A- (BROWN wire); signal A in A+ (WHITE wire); signal B_ in B- (BLACK wire); signal B in B+ (PINK wire); signal Z_ in Z- (YELLOW wire); signal Z in Z+ (LILAC wire).

NOTE 1: It is advised to use an encoder programmed with a number of pulses/revolution equal to 256 in order to obtain the best compromise between control precision in feedback and maximum rotor speed allowed; for applications where greater control precision is needed, but at a slower speed, there is the option of encoders programmed at 512 pulses/revolution.

NOTE 2 : with NEO-WiFi-3 - NEO-WiFi-4 - NEO-WiFi-5.5, it is necessary that the shaft rotation is clockwise.

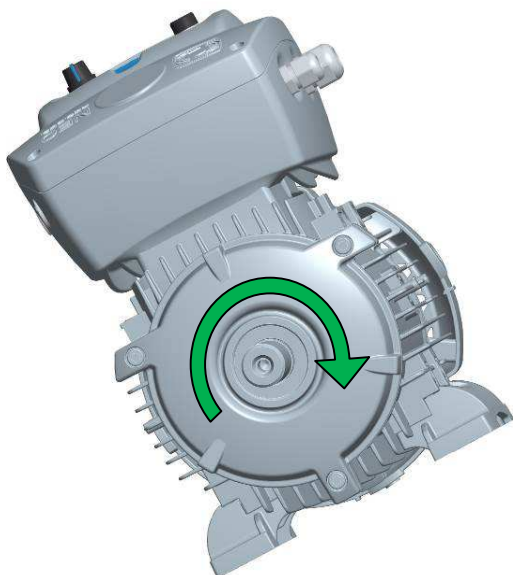

If you have a keypad with the rotation sense switch, this clockwise rotation sense corresponds to position 1



If the rotation is counter-clockwise, you must invert the position of the 2 encoder wires connected into E1 and E2.
In case of wrong rotation sense or connection, the alarm of overcurrent will appear.

- Optional connection Proximity Sensor (alternative to the encoder): It is also possible to connect a pulse counter (without determining the direction of rotation) constituted by a proximity sensor: +Vcc of the proximity on +15V pole

III.EN. Encoder connection- NEO-WiFi-3 - NEO-WiFi-4 - NEO-WiFi-5.5

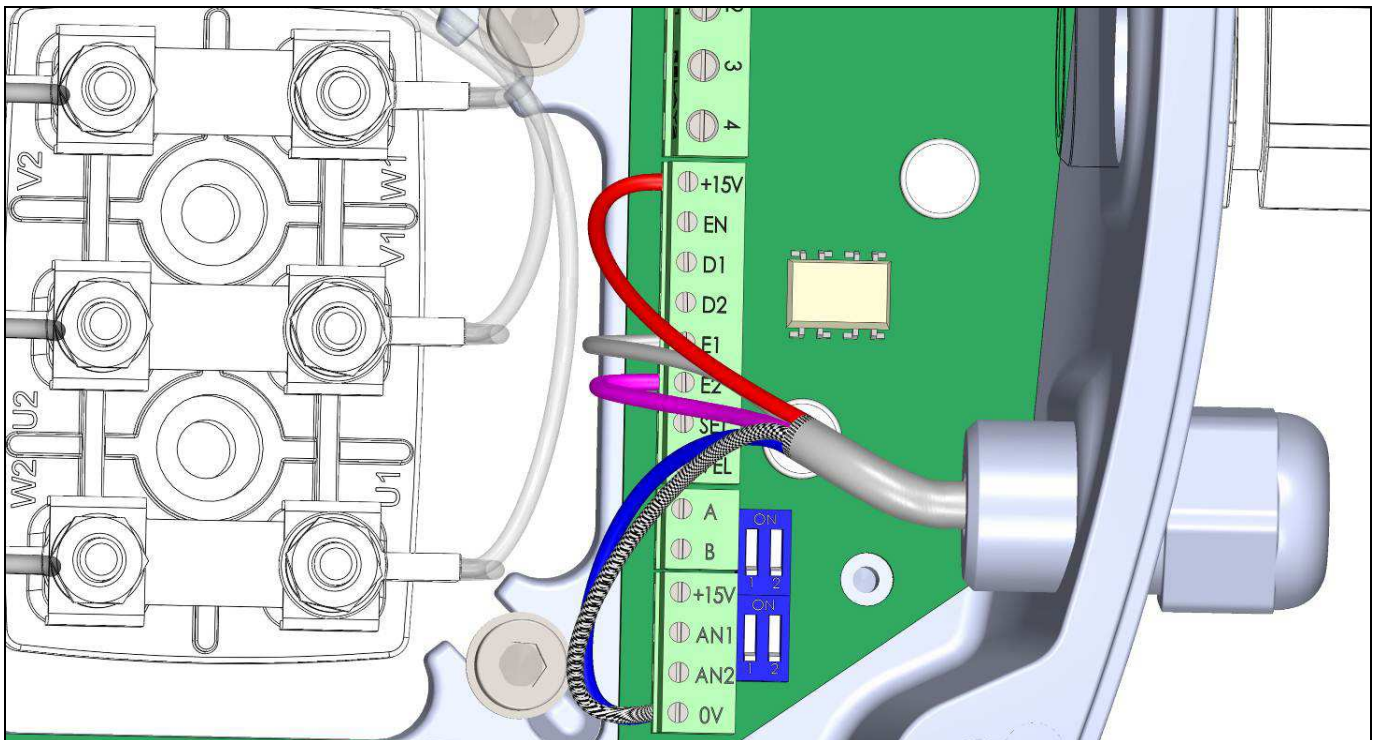
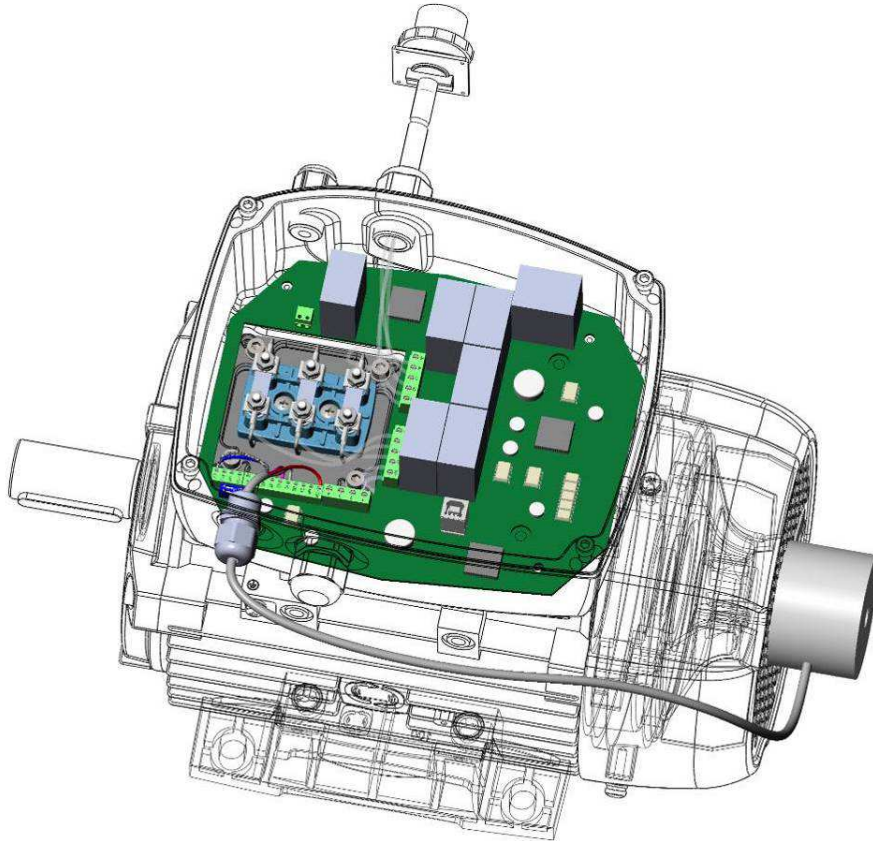

III. EN. Encoder connection - NEO-WiFi-11 - NEO-WiFi-22

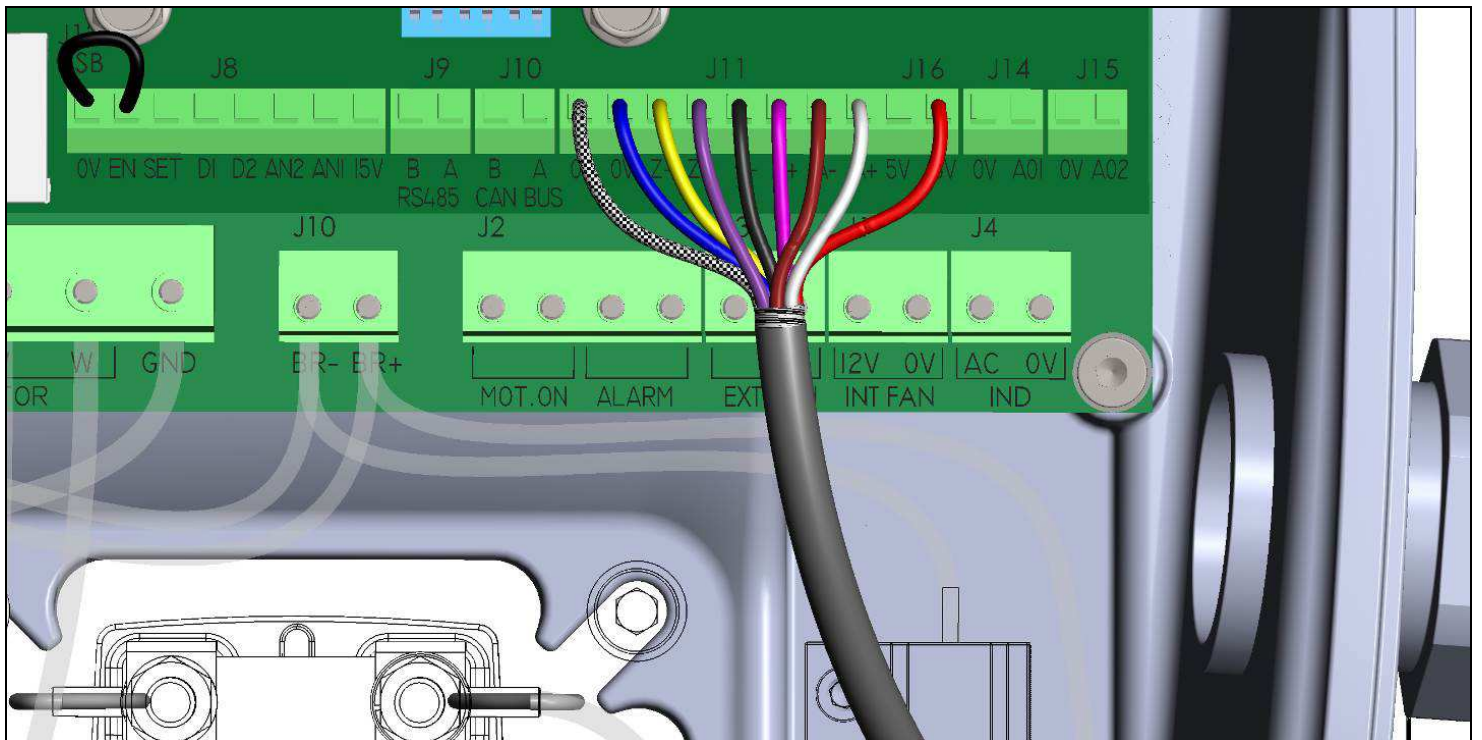
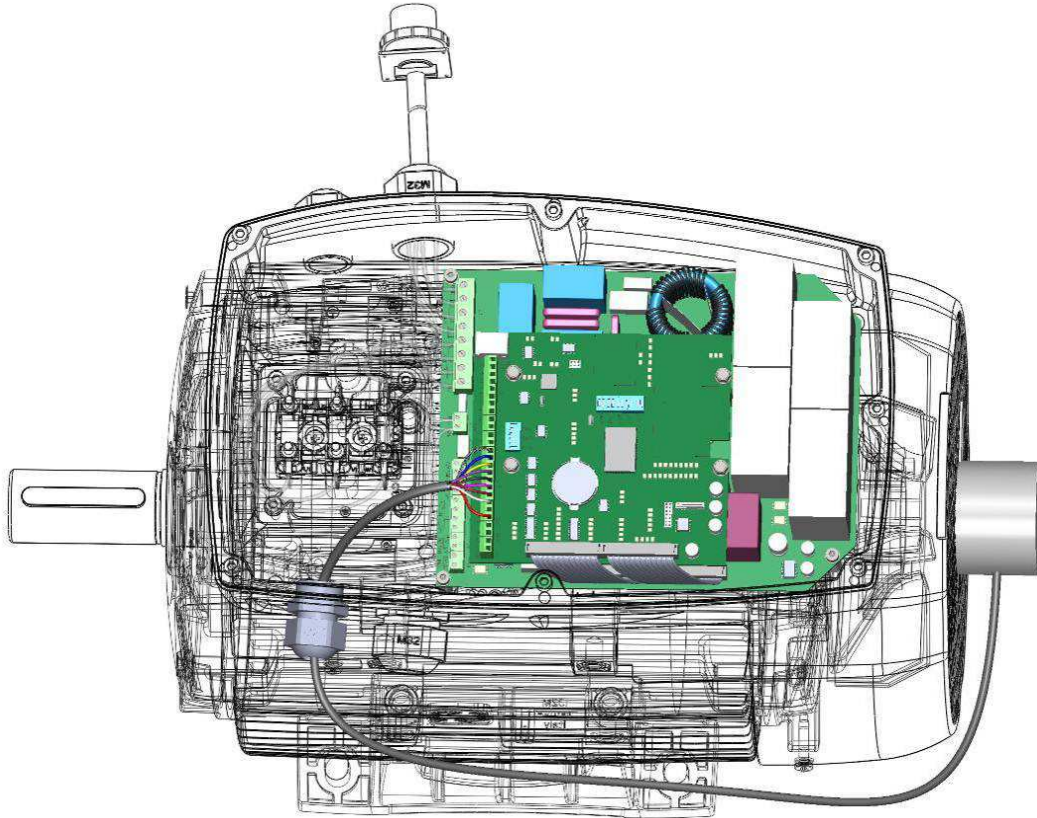

III. Motor with standard encoder and with forced ventilation:

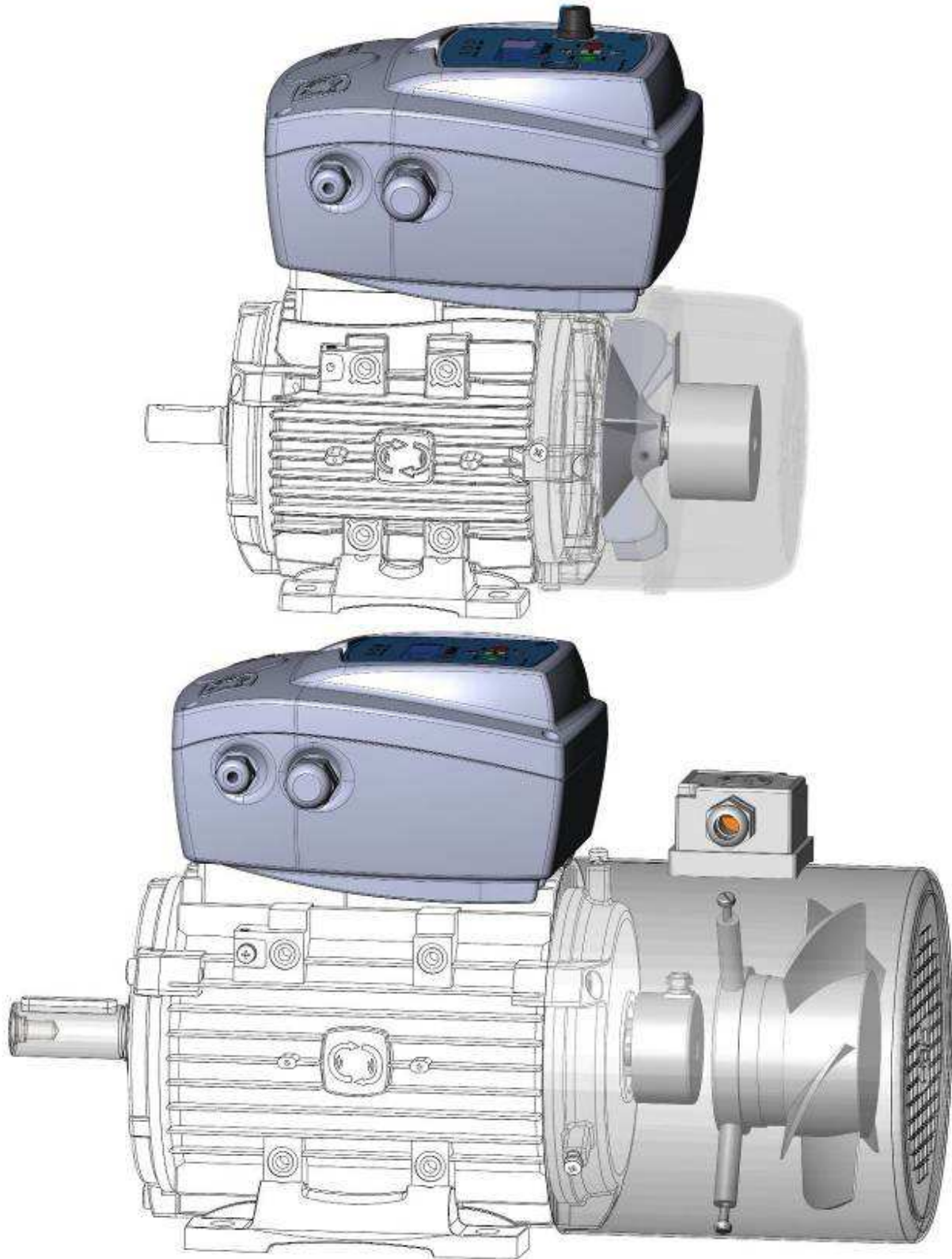

- Optional connection: AN2 external potentiometer min 2,2K Ω max 4,7K Ω (go to advanced functions menu)

NEO-WiFi-3 - NEO-WiFi-4 - NEO-WiFi-5.5

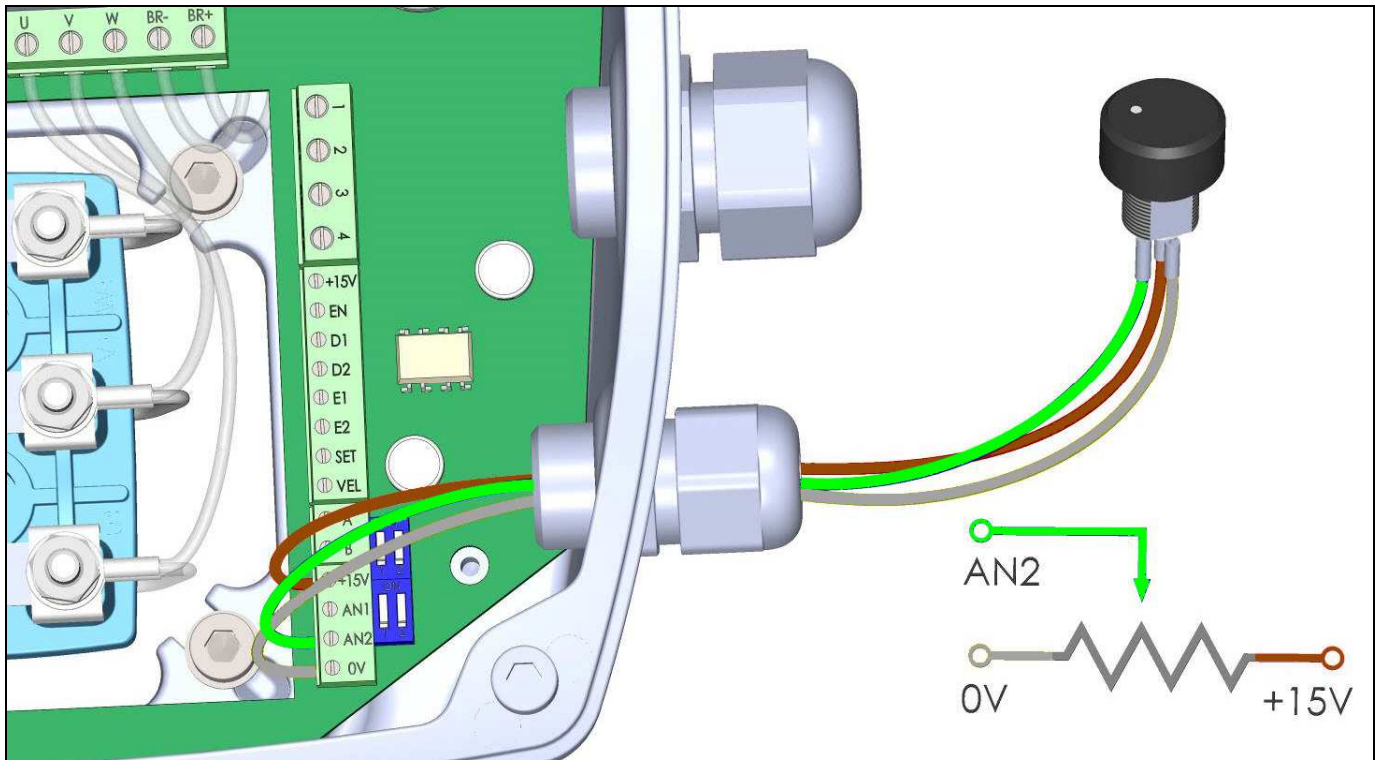

NEO-WiFi-11 - NEO-WiFi-22

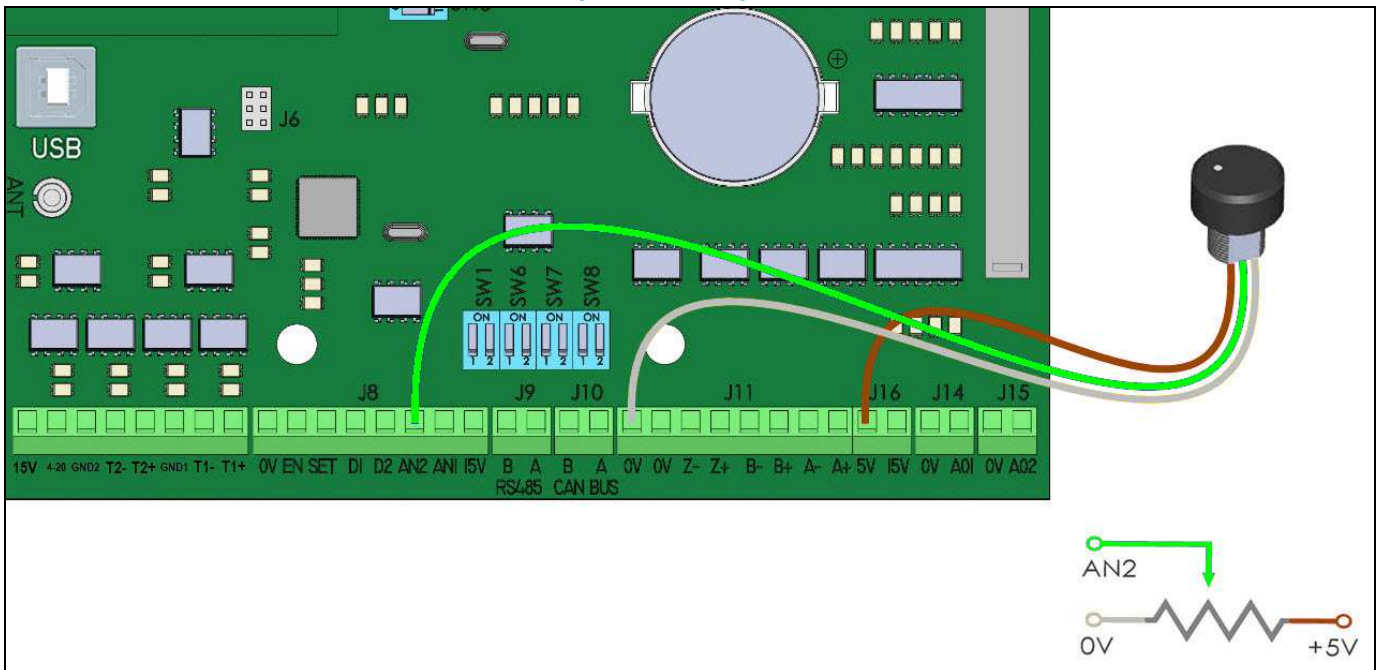

- Pressure transducers connection (for pressure feedback in NEO-COMP and NEO-VENT)

NEO-COMP-3 - NEO-COMP-4 - NEO-COMP-5.5

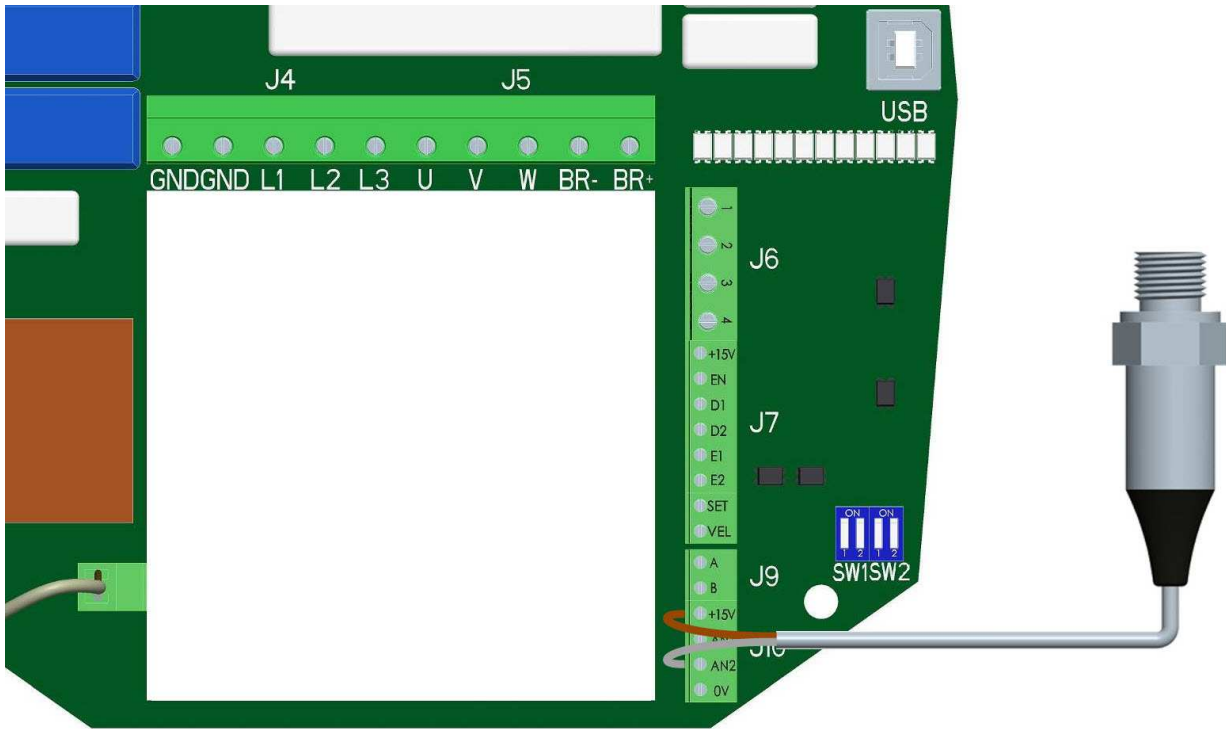

NEO-VENT-3 - NEO-VENT-4 - NEO-VENT-5.5

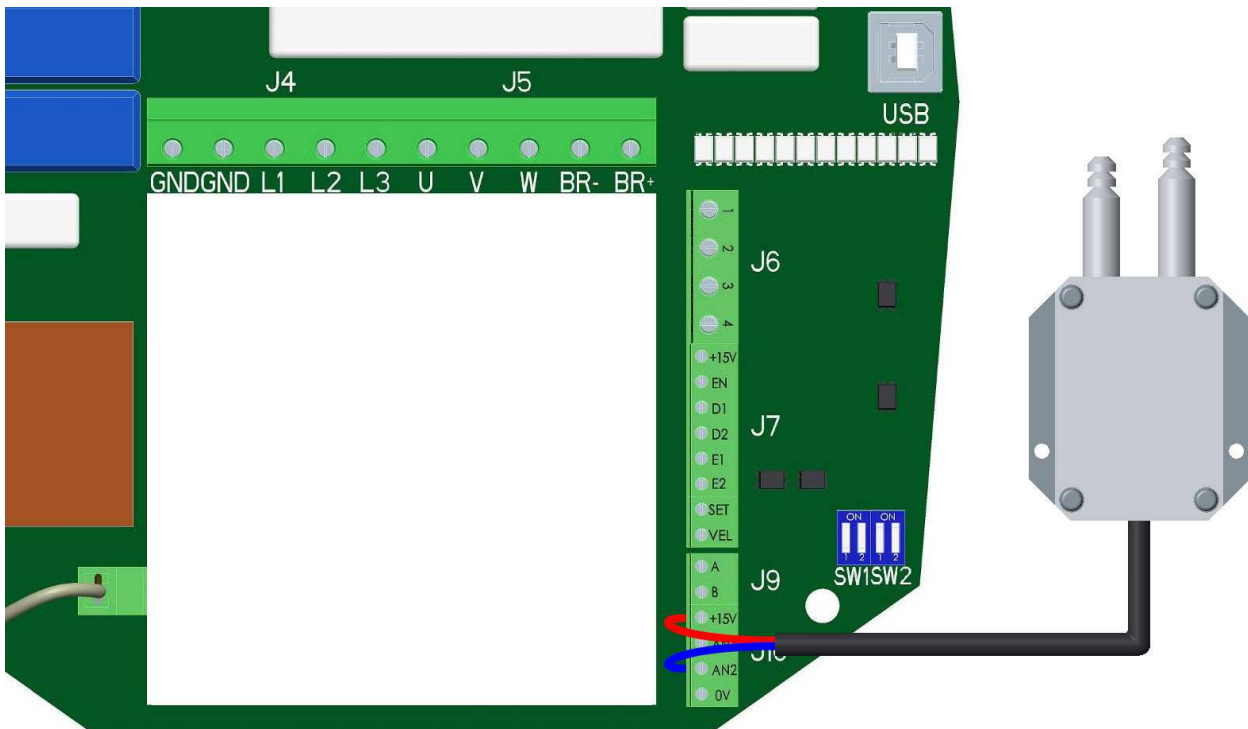

NEO-COMP-11 - NEO-COMP-22

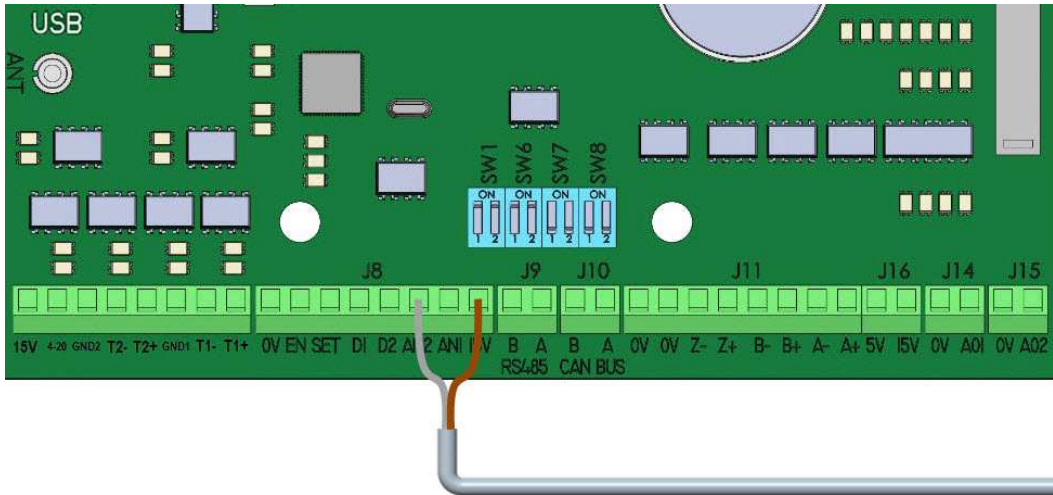

NEO-VENT-11 - NEO-VENT-22

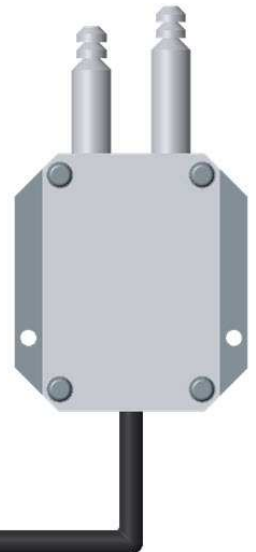
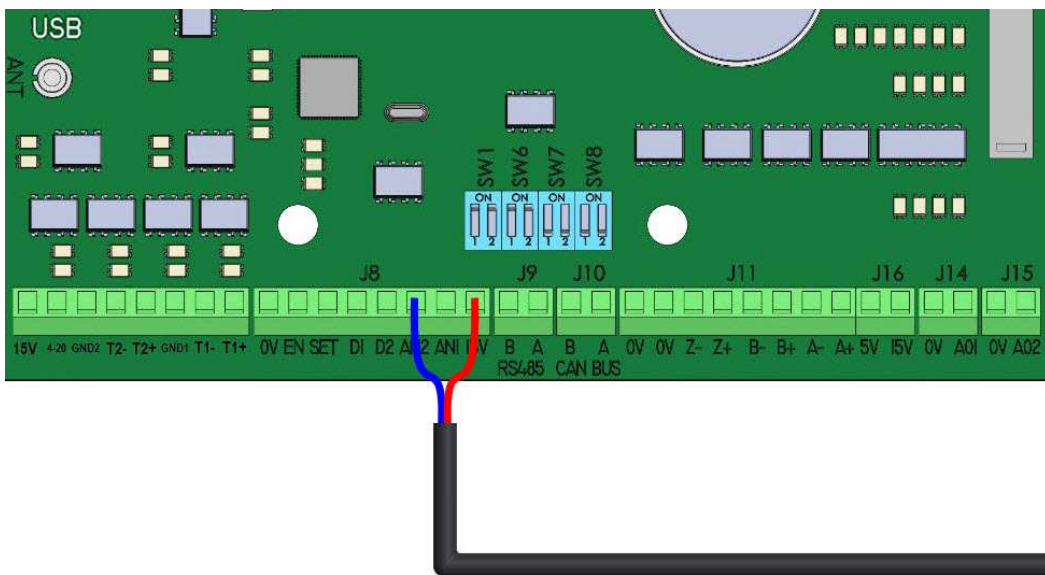

- Bluetooth module connection for smartphone and tablet control (optional code BLUE).



Functioning

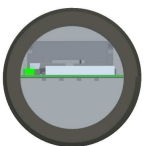

Steady green light: BLUE is powered correctly, waiting for connection to your device



Flashing green light: BLUE is connected to your device

Program the modbus communication parameter as follows:
 ADVANCED FUNCTIONS→MODBUS→MB COMM.→ON (=Program and control only by modbus).

NEO-WiFi-3 - NEO-WiFi-4 - NEO-WiFi-5.5

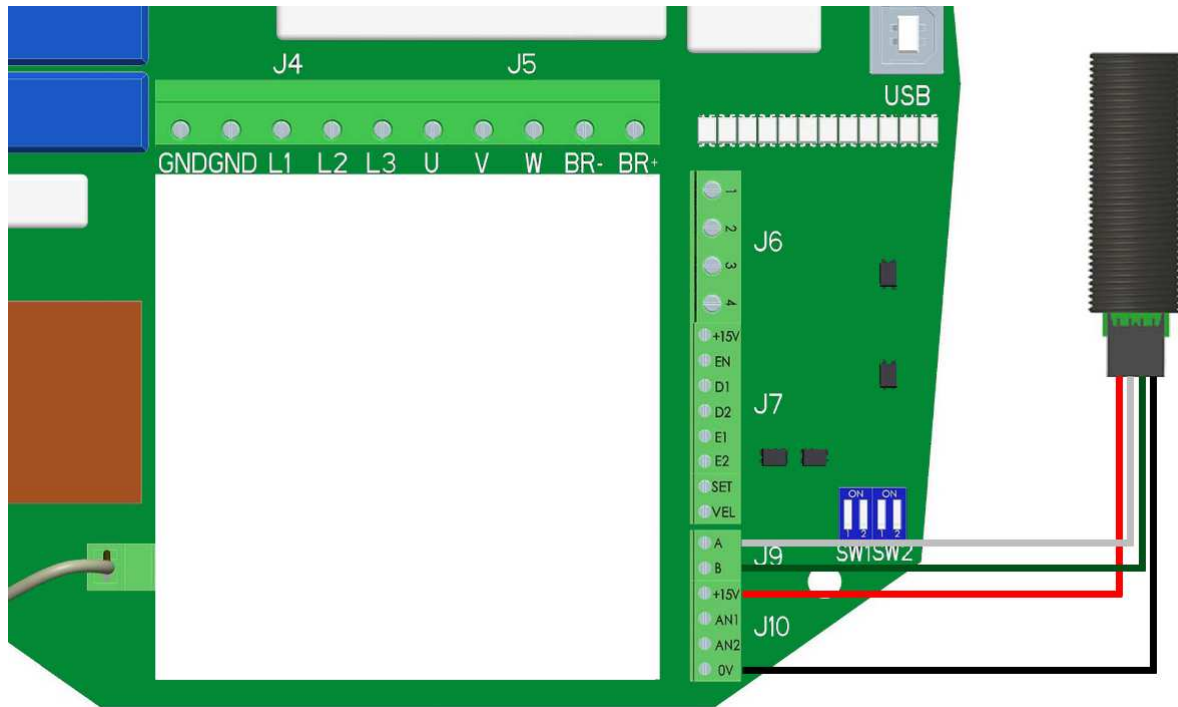

NEO-WiFi-11 - NEO-WiFi-22

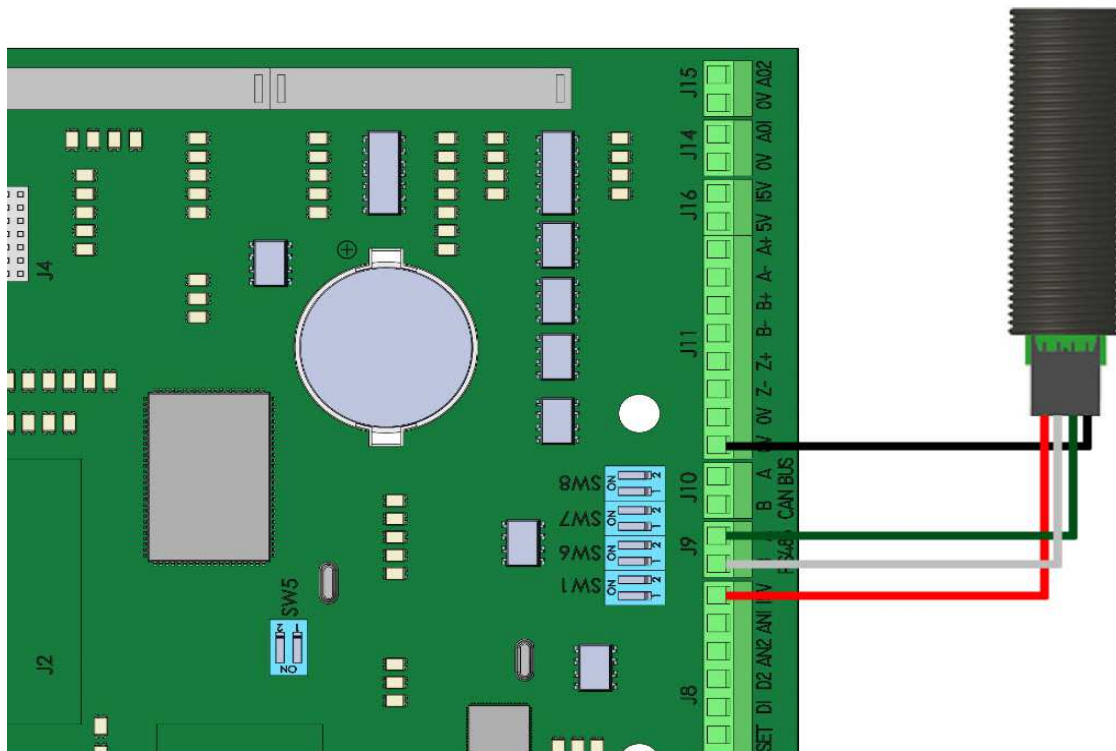

5d.2. Bluetooth module mounting (optional code BLUE)

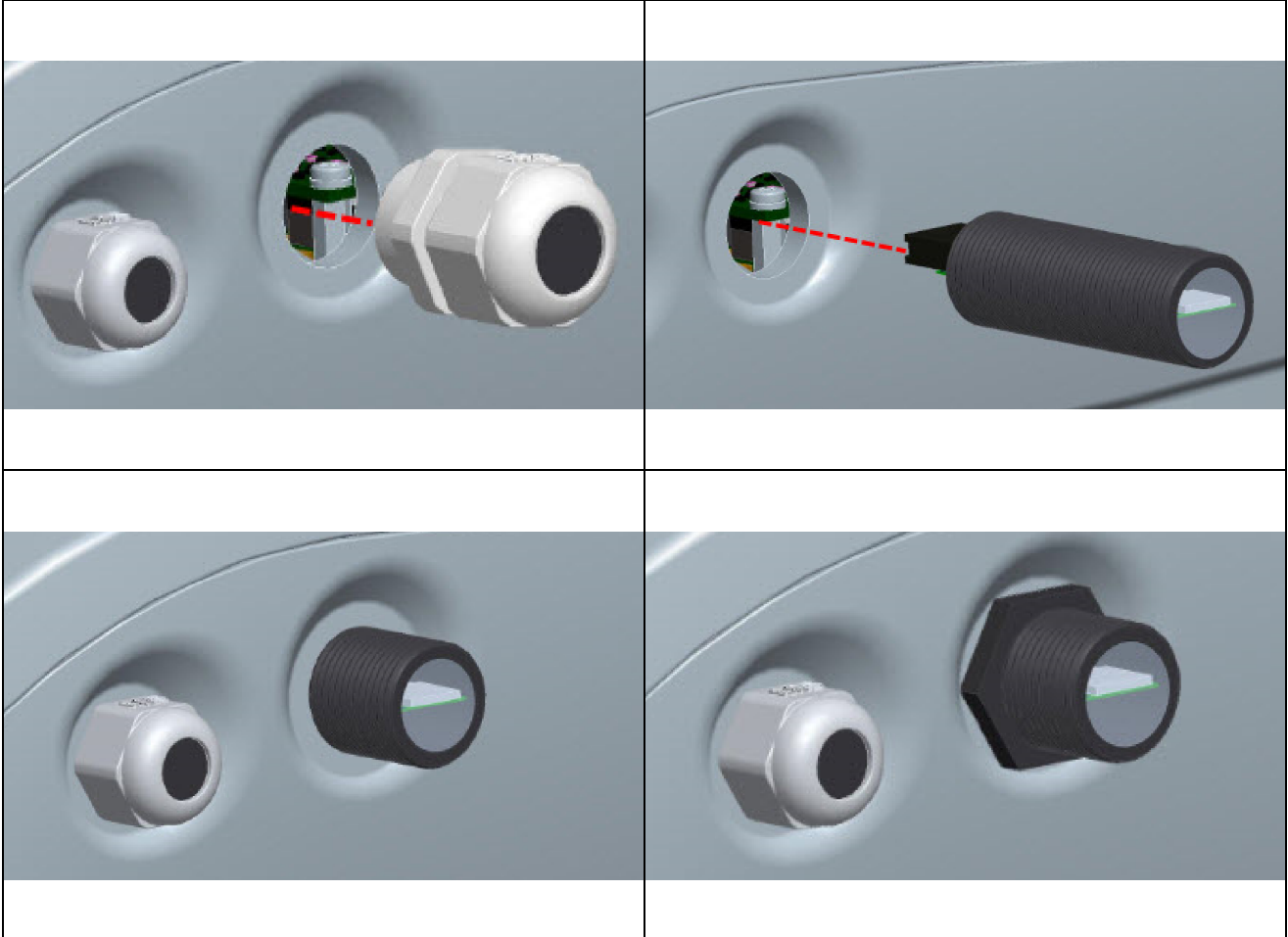

5d.3. 3PH Power switch mounting (optional)

INTEM3X32A + NEO-WiFi-3

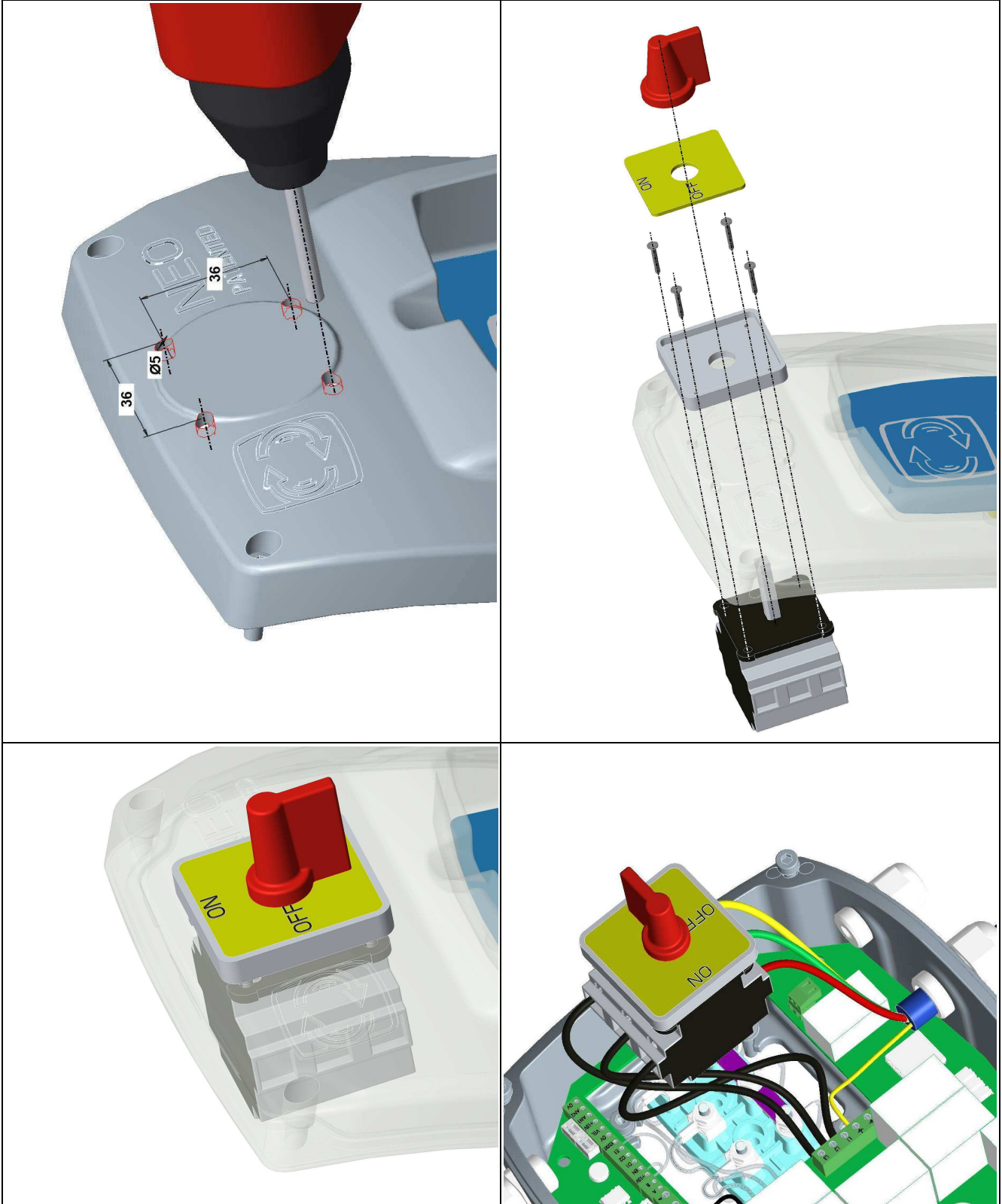

INTEM3X32A + NEO-WiFi-4 - NEO-WiFi-5.5 - NEO-WiFi-11

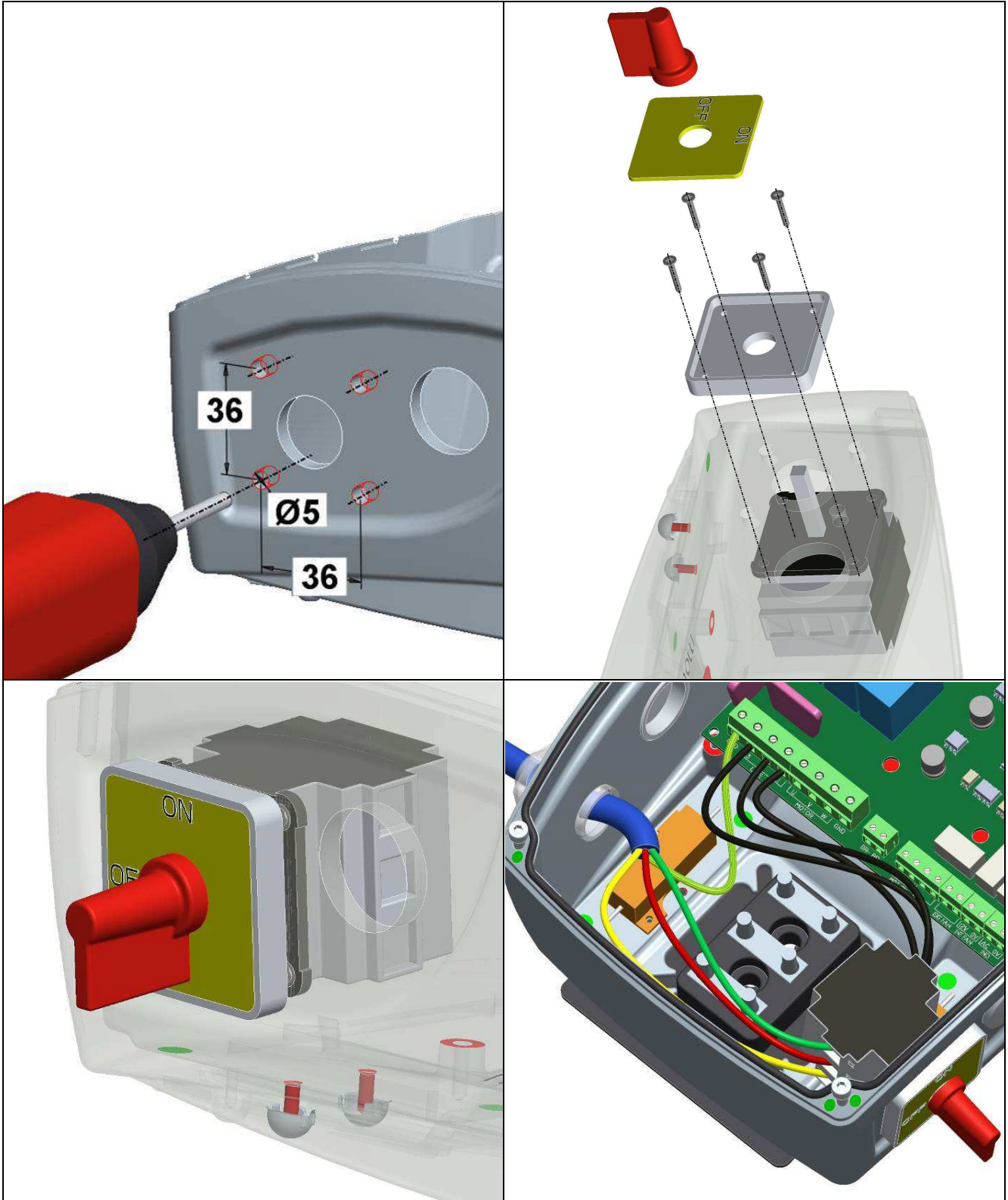

INTEM3X63A + NEO-WiFi-22

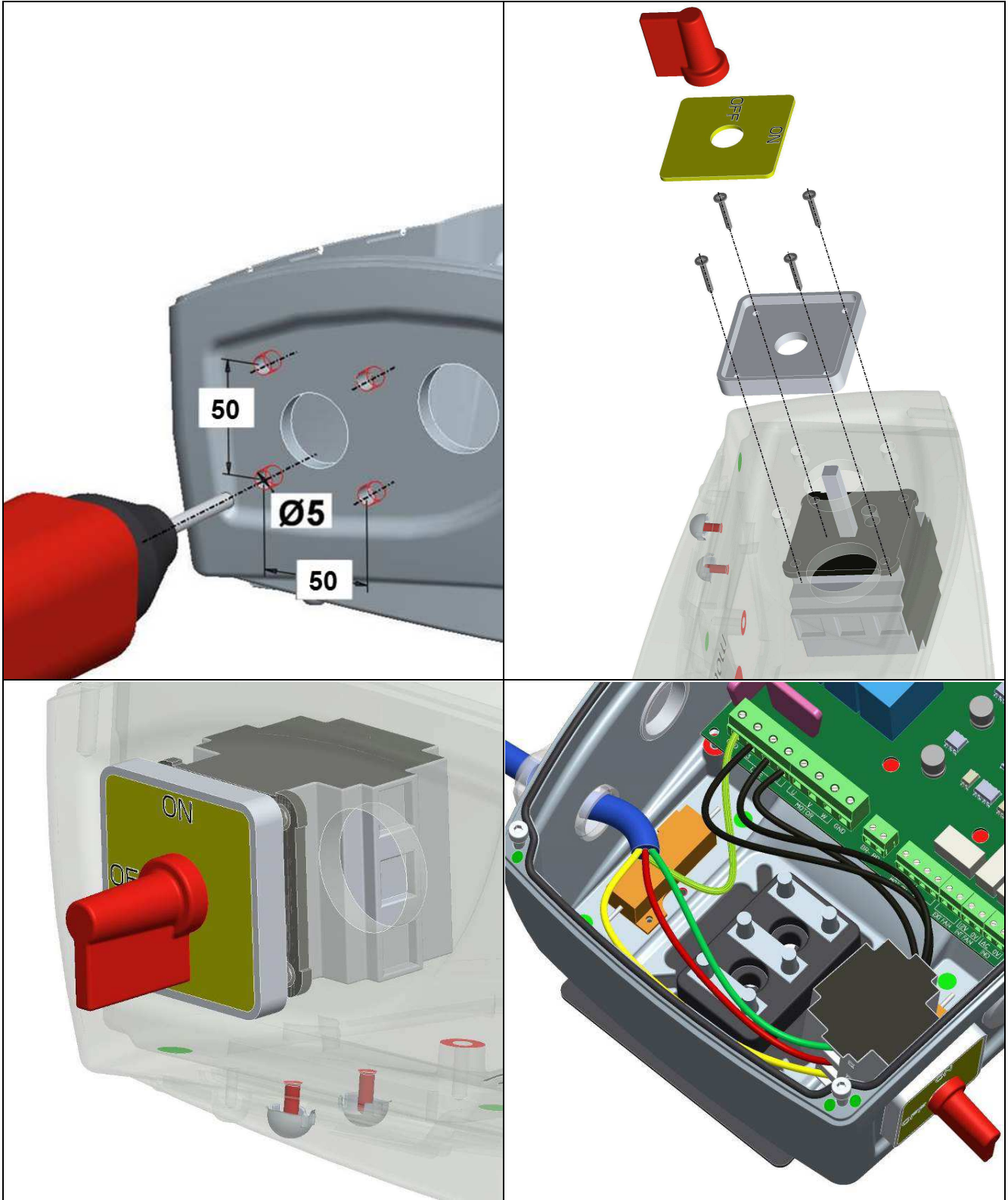

6. PROGRAMMING



The activation and programming operations must be carried out exclusively by experienced and qualified personnel. Use the appropriate equipment and protections. The powering of the inverter can be done only with box closed, after having carefully followed all the installation instructions of the electrical connections shown above. Follow the accident prevention regulations.

6a. First installation

After having made the connections described in chapter 4 of this manual proceed in the following manner, with remote controlled keypad in hand:

1. Power NEO-WiFi



2. Press  to enter into the menu →see functions menu

3. Set the motor data in the Data Motor menu, in particular by selecting values that can be taken from the plate of the motor for Rated power, rated Voltage and rated Current;

4. Press three times in rapid succession  to exit the main menu with automatic saving of the set parameters.
The confirmation text DATA SAVED must appear;

6a.1. Adjustment of the Keypad-Inverter communication

FOLLOWING POINTS TO BE READ ONLY IF YOU NEED TO MODIFY THE WIFI KEYPAD COMMUNICATION CHANNEL OR FREQUENCY (to be done in case that more than one NEO-WiFi are in the same place):

Close the contact to +15V- SET (NEO-3/4/5.5) / 0V-SET (NEO-11/22) terminals (III.X) to enable the selection of the communication channel (1-15) or the communication frequency 860..879 MHz

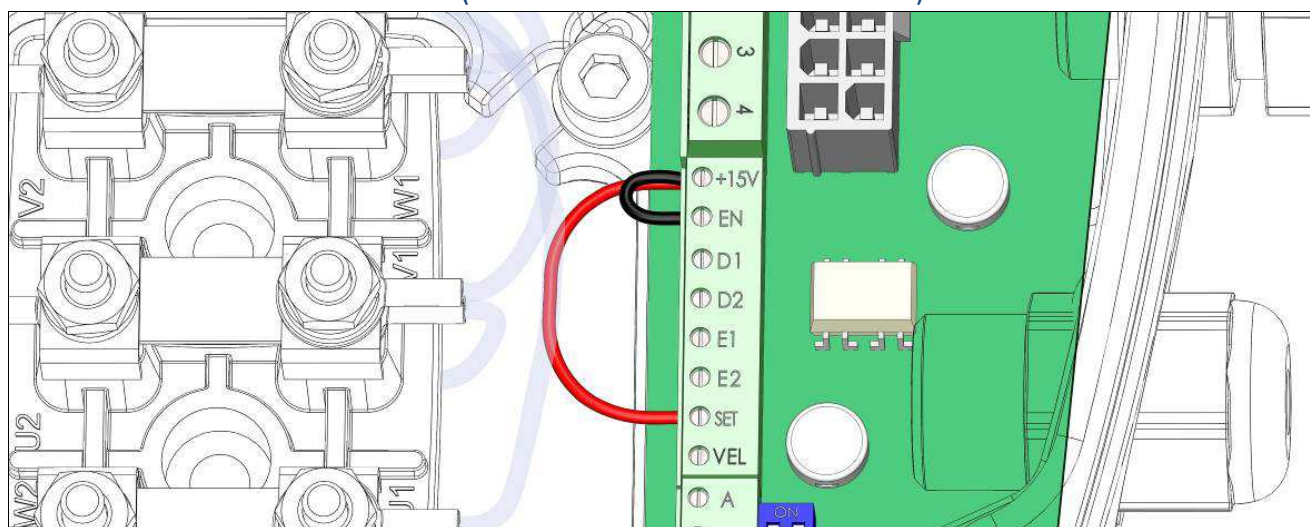

III. X (NEO-WiFi-3 - NEO-WiFi-4 - NEO-WiFi-5.5)



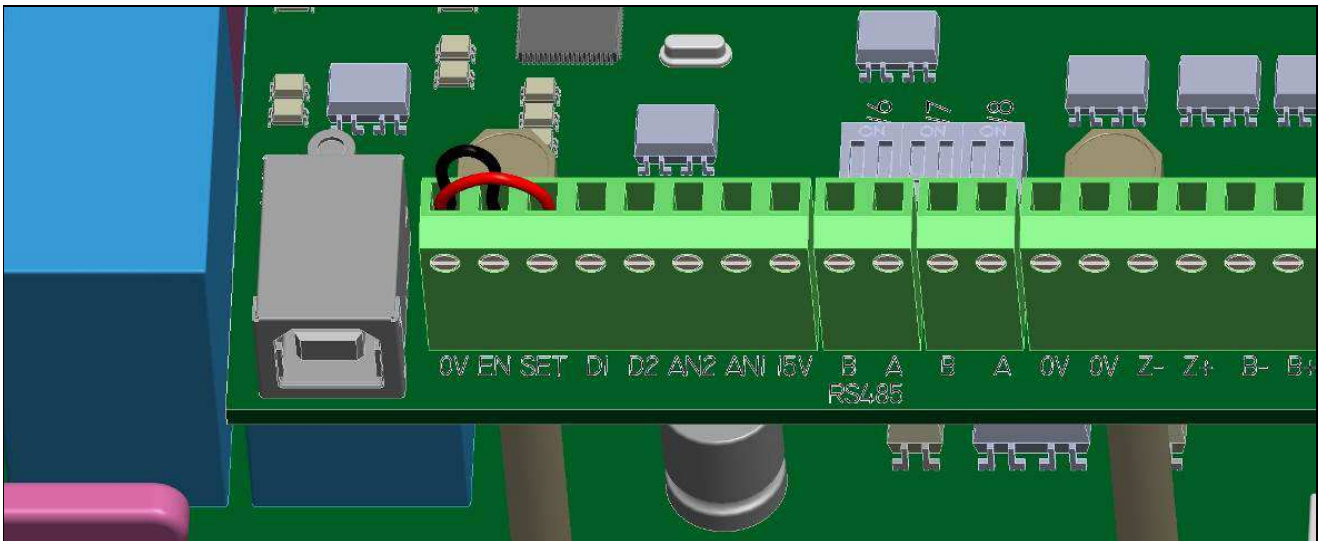

III. X (NEO-WiFi-11 - NEO-WiFi-22)



5. To modify the communication channel, press  and go to *Communication > Auto tuning (set)*. Automatically it will scan the MHz frequency and then shows the channel *Code Motor:1 Radio MHz:870* set by default by Motive.

Once established the communication, the POWER led on the keypad will light on. Select with   the wanted new



channel between 1 and 15 and the radio frequency between 860 and 879MHz (ex.), then press ENTER  to confirm and 3 times in rapid sequence the ESC button  to exit and save the data that will be confirmed by the display of the keypad (DATA SAVED).

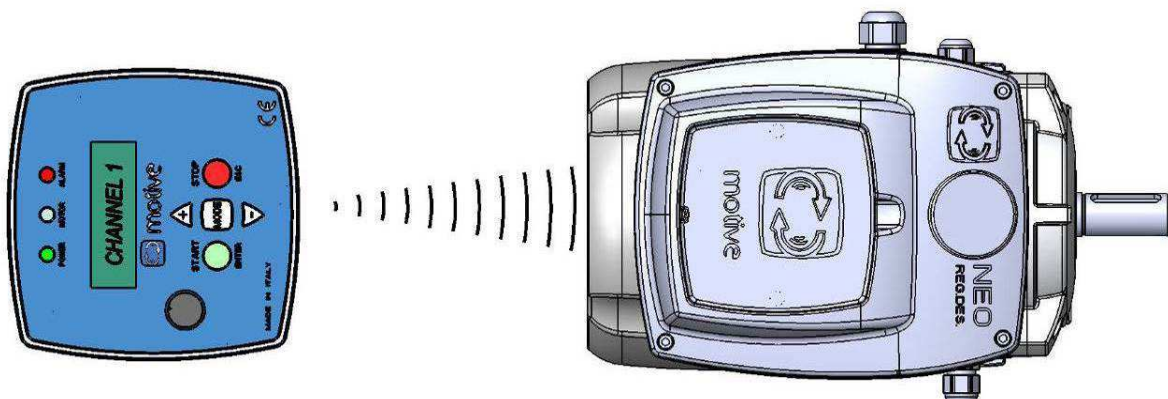

6. Only after that you modified the communication channel or frequency, remove jumper
 +15V- SET (NEO-3/4/5.5) / 0V-SET (NEO-11/22) (III.Y)

III. Y (NEO-WiFi-3 - NEO-WiFi-4 - NEO-WiFi-5.5)

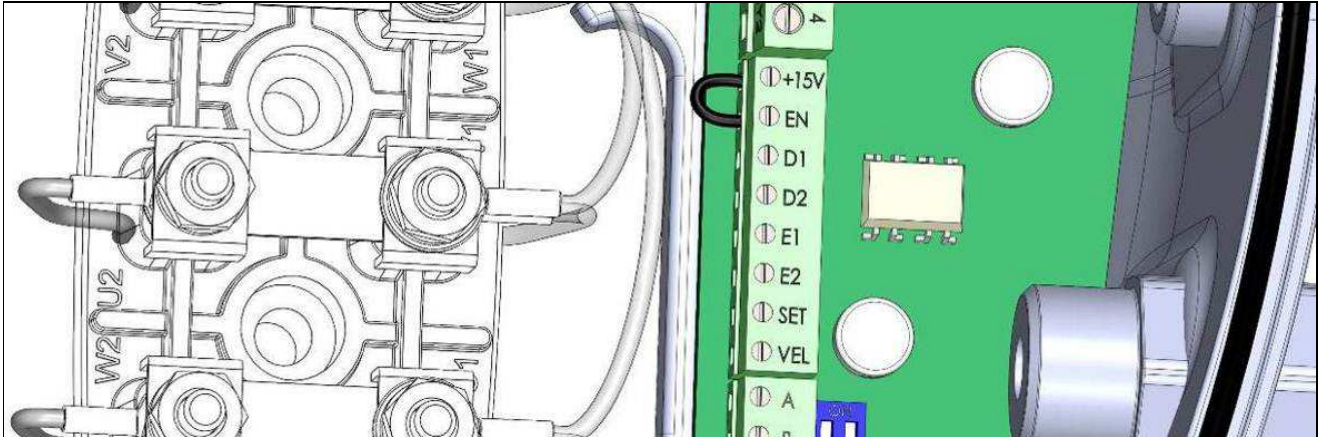

III. Y (NEO-WiFi-11 - NEO-WiFi-22)

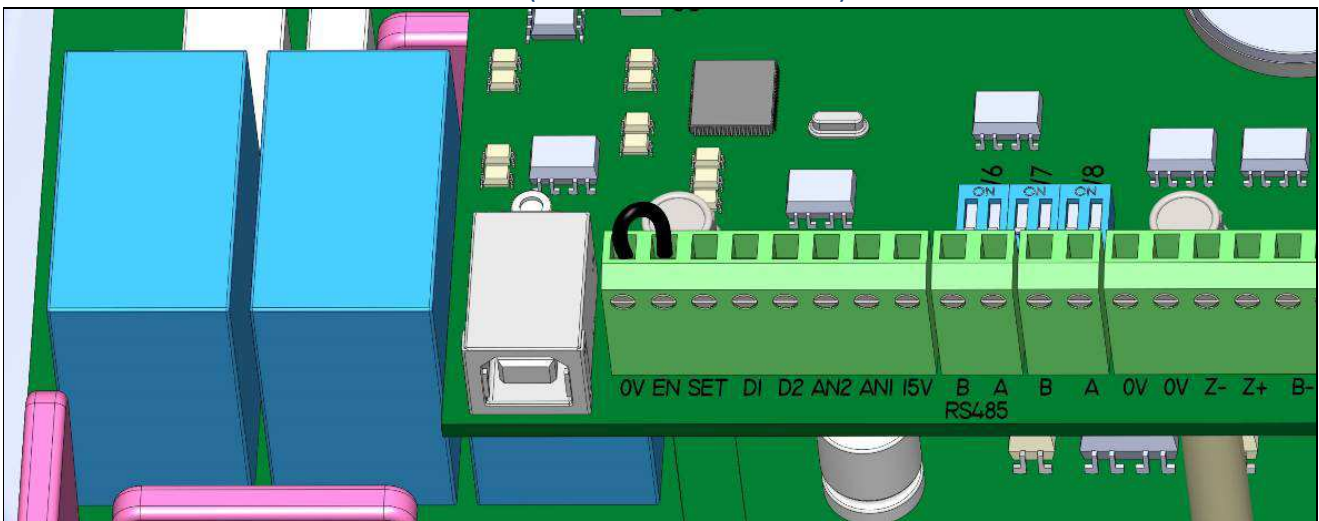

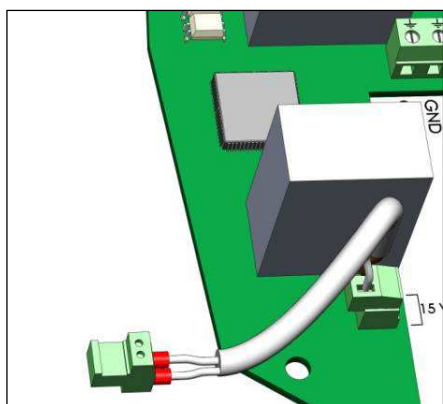

7. Close the lid, carefully repositioning the connections of inductive power supply and antenna.



COAXIAL CABLE CONNECTOR ON THE POWER BOARD: When connecting the coaxial cable to the power board, do not use metal tools that may damage the surrounding SMD electrical components that are extremely delicate.

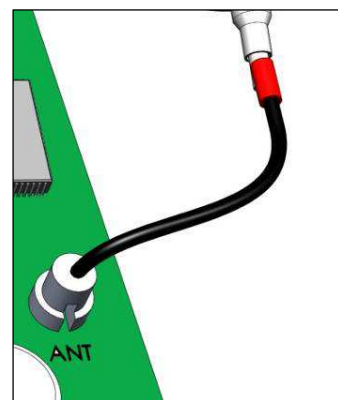

- The remote control of multiple motors from a single keypad is not possible, with a single communication channel



In fact, there is a continuous communication between the keypad and the inverters, communication that is not only a return of data to the display, but is also a synchronization of the behaviour of the inverter compared to what is pre-set and controlled from the keypad.

- It is instead possible to obtain a synchronous behaviour of 1÷8 NEO-WiFi with one keypad, connected them in master-slave mode. Slaves work without keypad, once they have been configured in the RS485 connection (Note: during the configuration with jumper +15V- SET (NEO-3/4/5.5) / 0V-SET (NEO-11/22) they must be switched on one by one, without 2 NEOs on at the same time)



- Separate control of multiple motors with multiple keypads with separate channels from 1 to 15 (for each frequency)

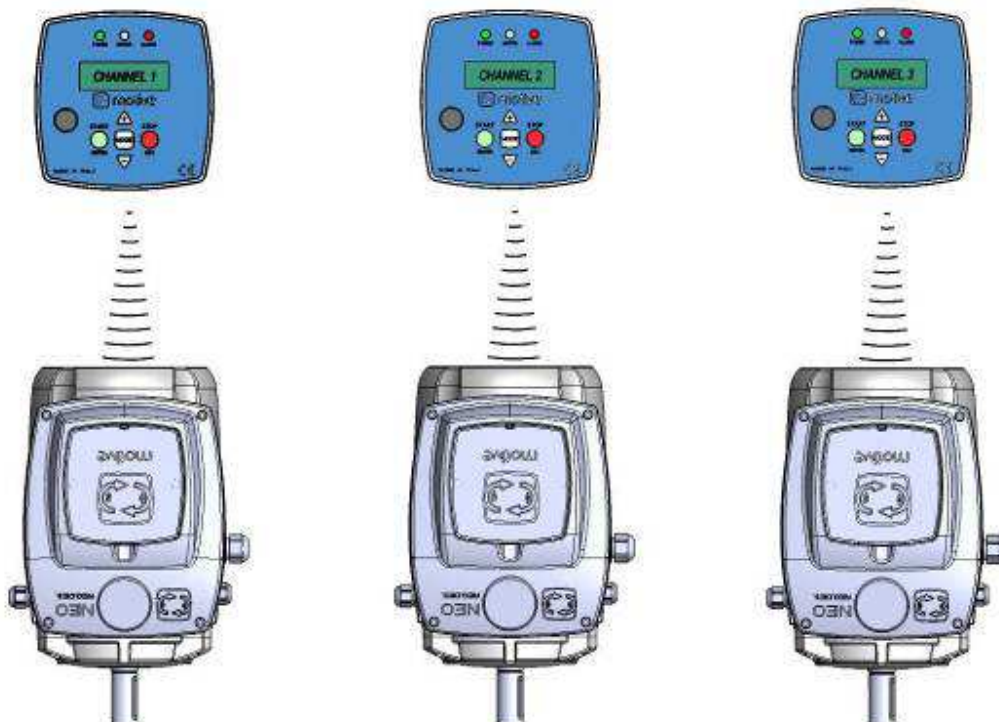

When there are multiple NEO-WIFI inverters in the same place, at distances of less than 80 mt:

- To change code and frequency close the +15V- SET (NEO-3/4/5.5) / 0V-SET (NEO-11/22) contact that simultaneously prevents the motor from running when closed ;
- When there are two or more motors with NEO-WIFI inverters, for those that come after the first one (default at Code:1, MHz: 870) set frequency and code values that are different from the first one and from each other to be sure that no inverter keypad interferes with the power of another inverter;

- Once the frequency has been changed, in order for the inverter and the relative keypad to tune in to the new frequency, switch them both off (by disconnecting the supply to the inverter power and pressing the STOP button on the keypad for 5 seconds) and then switch them back on (by reconnecting the power and pressing MODE on the keypad);
 - If, for any reason, the inverter and related keypad should lose communication, by constantly signalling "WAITING COMMUNICATION" on the display, switch both of them off and back on; if the communication is not restored, close the +15V- SET (NEO-3/4/5.5) / 0V-SET (NEO-11/22) bridge, supply power, turn on the keypad and enter the "COMMUNICATION" function that will display the active code and frequency status (the # symbols must disappear); if needed, modify then exit by pressing ESC twice in rapid sequence, which automatically saves the data
- It is not possible to have more than one keypad that controls a single inverter. They would conflict



In fact, there is a continuous communication keypad-NEO, in 2 directions. The communication from NEO to keypad is to monitor NEO-WiFi data on the keypad display, and also taking to a continuous synchronization of NEO-WiFi working compared to what it was set in the keypad.

6b. Keypad buttons







Button	Description
	To enter the function menu
START  ENTER	To start the engine / to access the sub-menu or to enter the function and change its values
	<p>Allows you to scrolls up through the menu items or change in positive the values of the variables; at the end of the change press ENTER.</p> <p>During operation also allows to increase the speed of the motor (if set speed signal = internal speed), which is saved automatically after 10 seconds from the change</p>
	<p>Allows you to scroll down through the menu items or change in negative the values of the variables; at the end of the change press ENTER.</p> <p>During operation also allows to increase the speed of the motor (if set speed signal = internal speed), which is saved automatically after 10 seconds from the change</p>
STOP  ESC	To stop the engine / to exit from the sub-menu (by entering the main menu); to exit from the main menu enabling the motor controls and automatically saving the set data if pressed in a rapid sequence (at the end it must show the writing "DATA SAVED").

Table 3: Buttons

6c. Keypad leds





Led	Description
Power ON	 Green - signals the presence of mains voltage on the feed
Motor ON	 Green - Motor functioning
Alarm	 Red – signals an anomaly (see list of Alarms) when turned on

Table 4: Led description

6d. Functions menu (from version SW 4.04NEO3 5.02NEO4 5.02NEO5.5 3.05NEO11 3.02NEO22 – 06/2019)



Menu	Sub-menu	Description
Language		Italian / English / German / French / Spanish
Communication 	Auto tuning (set)	 Automatic Motor code and radio frequency tuning. This function is enabled only if pins +15V and SET (for NEO-3/4/5.5) / 0V and SET (for NEO11/22) are connected by a cable bridge.
	Manual tuning	 <ol style="list-style-type: none"> 1. Motor Code (from 1 to 15) 2. Radio frequency (da 860 a 879 MHz) In manual tuning, it's not necessary connect +15V and SET (NEO-3) / 0V and SET (NEO-11/22)
Motor data (see motor nameplate)	1. Rated power P2 [kW]	1. 0.09 ÷ 3.0 (NEO-3); 0.09 ÷ 4.0 (NEO-4); 0.09 ÷ 5.5 (NEO-5.5); 0.09 ÷ 11.0 (NEO-11); 0.09 ÷ 22.0 (NEO-22)
	2. Rated voltage [V]	2. from 180 to 460
	3. Rated current [A] (set 107% of rated value of motor nameplate)	3. 0.6 ÷ 7A (NEO-3); 0.6 ÷ 10A (NEO-4); 0.6 ÷ 14A (NEO-5.5); 0.6 ÷ 22.0A (NEO-11); 0.6 ÷ 45.0A (NEO-22)
	4. Rated frequency [Hz]	4. 50 / 60
	5. Rated RPM	5. 350 ÷ 6000
	6. Power factor cosφ	6. 0.50 ÷ 0.90
	7. Rotation	7. 0=clockwise, 1=countdown clockwise
Advanced Functions	Access to the advanced functions menu	To access enter numeric access Password (number pre-assigned by Motive: 1).
Saving/Reset	Yes save: the changes made are saved Not save: returns to the values preceding the changes	Save the changed data, or restore the default values NOTE: auto-saves every time you exit the from function menu.
	Factory data: 1. Standard (Speed mode) 2. Ventilator 3. Air compressor 4. HP pump	CAUTION: Reset is enabled without the presence of the bridge +15V-SET (NEO-3) / 0V-SET (NEO-11/22) (Ill. X)

Table 5: Main menu

6e. Advanced functions menu (from version SW 4.04NEO3 5.02NEO4 5.02NEO5.5 3.05NEO11 3.02NEO22 – 06/2019)

Advanced Function Menu	Sub-menu	Description
Motor limits	1. Maximum speed [% of rpm]	1. from 50 to 200% of motor synchronous speed
	2. Minimum speed [% of rpm]	2. from 2 to 100% (NEO-3/4/5.5) of motor synchronous speed from 2 to 50% (NEO-11/22) of motor synchronous speed
	3. Acceleration [s]	3. from 0.1 to 999.9
	4. Deceleration [s]	4. from 0.1 to 999.9
	5. Maximum inrush current [%]	5. 80 ÷ 150 (NEO-3/4/5.5) (default 150)
		80 ÷ 160 (NEO-11) (default 160) 80 ÷ 150 (NEO-22) (default 150)
	6. Magnetization [%]	6. from 70 to 120. Default 100%. Increasing this %, at the same frequency, you increase the Volts to the motor (up to the max value of the power net voltage minus the circuit falls), thus increasing the magnetic flux in the motor. This raises the no-load current and enhances the torque up to the motor saturation. In case of electric vibration of the motor, you can make it disappear by reducing this % value. Do it at 2% steps till you get the required result.
7. Braking Joules	7. from 100 to 12700 [Joule]; default 300 (NEO-3) / 1000 (NEO-11/22). To be increased if external resistances are used NOTE: Energy loss [Joules] = Power dissipation [W] x Braking time [seconds].	
Control type	1. Enable restart	1. Enables the restart after a crash caused by lack of mains voltage or alarm (ENABLED / DISABLED). Default is DISABLED
	2. Dead Time after alarm [s]	2. Waiting time before the reboot, follows a stop caused by an alarm condition;
	3. Start/Stop Source	3.
		· from keypad button only
		· from keypad button and keypad selector · external remote wired control
	4. Input Signal	4.
		· Internal speed
		· keypad potentiometer · AN2 external potentiometer 15V(NEO3) / 5V (NEO11/22)
		· signal 0-10V on AN1 · signal 4-20mA on AN1
	5. Mode	5.
		· Open loop speed
		· Speed+encoder
		· Ventilator
		· Air compressor · HP pump

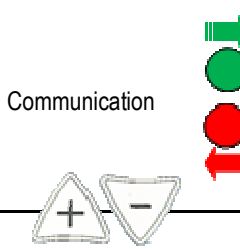
	6. RS485 Master Slave	6. Motor number / Total n. of motors in group (1/1 default for single motor; 1/2 for master motor of total 2 motors group, 2/2 for the slave motor of 2 motors group, etc- n. of slave motors max=8). This function is enabled only in Open loop Speed or Speed+encoder mode with Modbus=OFF.
	7. T/R fault stop (ON/OFF) (this function is there only from keypad version V.201 and NEO-WiFi-3 version V.2.01)	7. When this function is ON, it switches off the motor if the T/R radio communication between keypad and NEO is missing for more than 5 seconds. Default is set on OFF.
	8. Preheating temperature in stand-by [°C]	8. In case of wide thermal excursions, in order to avoid the condensation of water drops inside enclosure which could take to oxidation and/or to short circuit, the internal braking resistors are used to keep a minimum internal temperature (0+50°C, default 25°C). NEO-WIFI shall remain powered and the internal resistors must remain connected.
Feedback	1 Open loop speed:	
	1.1 Internal speed	1.1 From 17 to 6000 RPM. Default 280
	2 Speed with Encoder:	
	2.1 Encoder pulses/rotation integer	2.1 Integer part of pulses/rotation encoder (es. 256).
	2.2 Encoder pulses/rotation decimal	2.2 Decimal part of pulses/rotation encoder (es. 0).
	3. Pressure:	
	3.1 Pressure measure unit	3.1 bar / psi [Conversion: 1psi =0.0689bar]
	3.2 Min out P. (AN2)	3.2 From 0 to 10 mA
	3.3 Max out P. (AN2)	3.3 From 10 to 30 mA
	3.4 Sensor range	3.4 0.010 ÷ 16 bar / 0.14 ÷ 232 psi (Ventilator) 1 ÷ 160 bar / 14 ÷ 2325 psi (Air compressor) 1 ÷ 1600 bar / 14 ÷ 23250 psi (HP pump)
3.5 Pressure reference	3.5 0.005 ÷ 16 bar / 0.07 ÷ 232 psi (Ventilator) 0.5 ÷ 160 bar / 7 ÷ 2325 psi (Air compressor) 0.5 ÷ 1600 bar / 7 ÷ 23250 psi (HP pump)	
3.6 Pressure Hysteresis	3.6 0.001 ÷ 0.2 bar / 0.01 ÷ 2.90 psi (Ventilator) 0.1 ÷ 20 bar / 1 ÷ 290 psi (Air compressor) 0.1 ÷ 20 bar / 1 ÷ 290 psi (HP pump)	
3.7 Time stop at pressure reference (P min)	3.7 5 ÷ 300 Sec	
3.8 Stop power with no load	3.8 From 0 to 100% Pn	
Electromagnetic brake	Enabling this function, the electromagnetic brake is energized when the motor starts and is de-energized at the end of the deceleration ramp of the motor.	
	1. Enable Electromagnetic brake: ON/OFF	1. Brake enabling (1=ON is enabled, 0 is disabled), with terminations to be connected to BR+ and BR- of the power board; ATTENTION: always disconnect the braking resistances;
	2. Voltage [V] feed of the brake coil	2. Supply voltage of the brake coil, selectable between two values: 104Vdc or 180Vdc (download the DELPHI motor manual from www.motive.it).

P.I.D. factors (it's like a cruise control: NEO compares the rpm set by the keypad to a measured feedback)	For speed control in feedback	
	1. K Proportional factor	1. $K_{proportional}$: 1-100. Multiplies the error of the reference quantity
	2. K Integral factor	2. $K_{integral}$: 1-100. Multiplies the integral of the error
Clock setting (function based on the battery clock, which is there only on NEO-11 and NEO-22; not there on NEO-3)	Date and hour setting: to unlock the clock, modify the SECONDS value. The estimated duration of the clock battery type CR2430 is 6-8 years. After its replacement you must reset the clock and modify the seconds to unlock it.	Year: XX Month: XX Day: XX Hour: XX Minute: XX Second: XX
Starts Timer (function based on the battery clock, which is there only on NEO-11 and NEO-22; not there on NEO-3)	Timer ON/OFF	When the Timer is ON, you can set up to 5 programs (consecutive starts/stops) inside 24 hours, which will be repeated every day. Every day of the week will be the same, and you cannot set different programs for different week days.: · P1: XX (Start HOUR 1), YY (Start MIN 1); A1: ZZ (Stop HOUR 1); WW (Stop MIN 1); · P2: XX (Start HOUR 2), YY (Start MIN 2); A1: ZZ (Stop HOUR 2); WW (Stop MIN 2); · P3: XX (Start HOUR 3), YY (Start MIN 3); A1: ZZ (Stop HOUR 3); WW (Stop MIN 3); · P4: XX (Start HOUR 4), YY (Start MIN 4); A1: ZZ (Stop HOUR 4); WW (Stop MIN 4); · P5: XX (Start HOUR 5), YY (Start MIN 5); A1: ZZ (Stop HOUR 5); WW (Stop MIN 5).
RS485/MODBUS (see par. 6h)	1. MB comm.	1. OFF= modbus disabled; ON= programming and working only by MODBUS ON+KEY = Prgramming by MODBUS and working by keypad (including further remote wired commands and speed signals)
	2. Baude Rate;	2. 4800 – 9600 (default) – 14400 – 19200. It shows the bits speed transmission in bits/second. The transmitted bits include start bits, data bits and parity bits (if used), and stop bits. However, only data bits are memorized.
	3. Modbus Code;	3. From 1 to 127 (default = 1)





Alarm history	List of alarms recorded	View in chronological order (from first to last) all the last 99 Alarm events (chap. 6g) recorded during the life of the inverter. The same data is saved in the memory and is made available for analysis from the PC by means of a USB connection for the technical support and repair service (ATTENTION: only with inverter not powered).
---------------	-------------------------	---

Table 6: Advanced functions menu

NOTE: The keypad automatically recognizes if it's connected to a NEO-WiFi-3, a NEO-WiFi-4, a NEO-WiFi-5.5, a NEO-WiFi-11 or a NEO-WiFi-22, and changes the enabled limits and functions of the menu according to that.

6f. Use

Start the motor by pressing the START button  (or the remote switch in case of remote controls with wired connection) – and adjust the speed using the commands   .. and/or, if present, with the potentiometer with wheel present on the keypad and possibly changing the direction of rotation with the software and/or, if present, by acting on the 1-0-2 selector

The keypad during the functioning of the motor shows, alternating them, the following two sets of data:

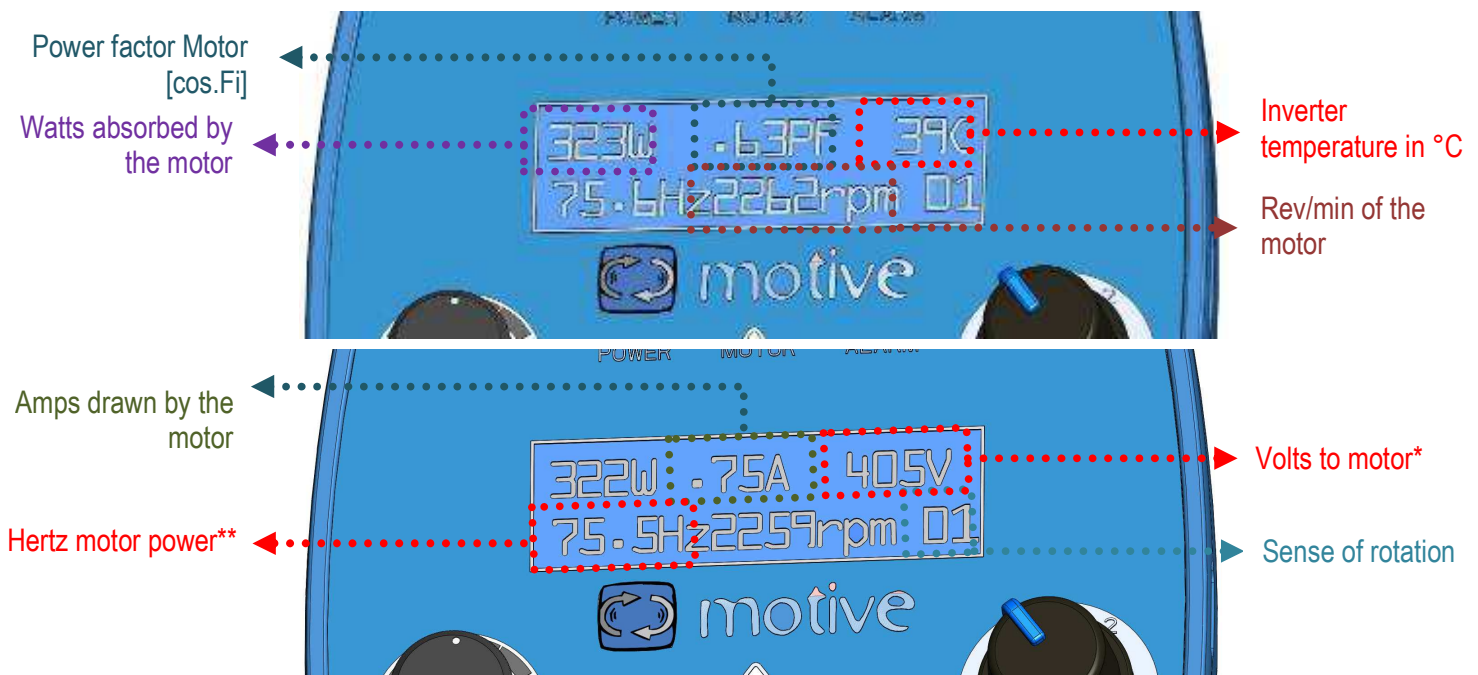

*The **Volts** to the motor are never as much as the Volts into the inverter from the net. The first stage in which any inverter rectifies the input voltage from ac to dc reduces about 8% the Volts. At a frequency lower than 100% of the net, such 8% effect disappears gradually, but it remains the following further falls of voltage. In fact, any inverter has further internal voltage falls of about 5-6V for diodes, IGBT bridge, and the inductance filter. So, with an input of 400V into an inverter, the voltage to the motor is about 362V at 100% frequency. The motor works anyway without any trouble because the inverter sets the magnetic flux according to such real voltage.

****Hertz**: In speed control NEO-WiFi chases the RPM speed not the frequency Hz. If for example the motor torque increases, NEO-WiFi tends to compensate such higher resistance by increasing the Hz to the motor in order to maintain constant RPM. This is true both with and without encoder encoder (in the latter case less accurately calculated).

Since keypad version V1.12 (you can see it for 2 seconds when you switch the keypad on) it is possible to see the battery charge.



For that, keep MODE  pressed for min 1 second (16 squares = fully charged);

Let's say that you used NEO-WiFi in a demo single phase power supply for which it isn't designed. In such a version, the T/R communication of the keypad may waste more batteries power than the power supplied by the NEO embedded recharger, which is in fact designed for a three-phase connection. So, now the keypad batteries are down, you cannot give a proper three-phase connection to NEO-WiFi and you don't have BLOCK. But you need to recharge the batteries anyway. The solution is the SLEEP MODE. Lay the keypad inside NEO-Wifi



recharging seat, then keep the keypad stop button  pressed for 5 seconds. The keypad microprocessor will then shift to SLEEP MODE, which means that the microprocessor stops its functions, including T/R radio communication. In this way, even if in demo single phase power connection, the batteries will recharge. The display will show such a status. To go out from the sleep mode, you just have to take out of the recharging seat the keypad and put it back into it.



6g. Alarms (from Version 1.10)

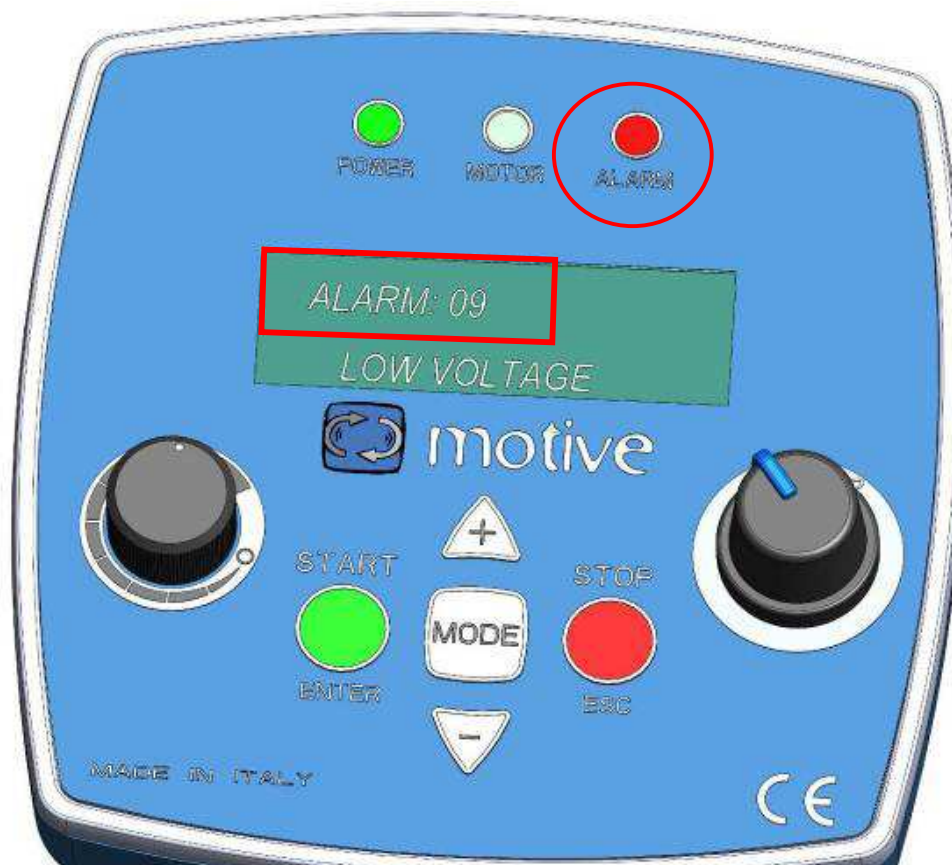

			NEO 3	NEO 4	NEO 5.5	NEO 11	NEO 22
1	Current peak	Immediate intervention for short circuit	✓	✓	✓	✓	✓
2	Overvoltage	Overvoltage due to the generator functioning during deceleration or undervoltage	✓	✓	✓	✓	✓
3	Inverter temperature	Exceeding the temperature limit on the electronic board (86°C)	✓	✓	✓	✓	✓
4	Motor heating	Motor thermal protection (it works on the same principle of thermal magnetic circuit breakers: the current)	✓	✓	✓	✓	✓
5	Encoder problem	Alarm due to a problem with the encoder with speed control in feedback	✓	✓	✓	✓	✓
6	Enable Off	Enable contact +15V- EN(NEO-3/4/5.5) / 0V-EN (NEO-11/22) open; motor cannot work when this contact is open.	✓	✓	✓	✓	✓
7	Overcurrent/Locked rotor	Working only with speed control feedback via encoder, if locked for more than 10 seconds. In NEO-WiFi-11 and NEO-WiFi-22, It also shows the eventual inversion of A+ and A- encoder wires.	✓	✓	✓	✓	✓
8	IN-OUT inversion	Possible inversion error of the input and output cables of motor and line	✓	✓	✓	✓	✓
9	Undervoltage	Voltage value insufficient to keep the engine running at a given load condition	✓	✓	✓	✓	✓
10	Communication error	Radio communication error between keypad and inverter – possible interference on the transmitted signal or incompatibility of keypad and inverter software versions.	✓	✓	✓	✓	✓



11	Overcurrent	Intervention for current overload on NEO-WiFi output to/by the motor	✓	✓	✓	✓	✓
12	microprocessor temperature	Intervention for microprocessor overheat	✗	✗	✗	✓	✓
13	phase U overcurrent	current overload on NEO-WiFi output to/by the motor on phase U	✗	✗	✗	✓	✓
14	phase V overcurrent	current overload on NEO-WiFi output to/by the motor on phase V	✗	✗	✗	✓	✓
15	phase W overcurrent	current overload on NEO-WiFi output to/by the motor on phase W	✗	✗	✗	✓	✓
16	Braking peak	Overcurrent into the terminals BR+/BR-	✗	✗	✗	✓	✓
17	Read error I1	current I1 read error, on phase U	✗	✗	✗	✓	✓
18	Read error I2	current I2 read error, on phase V	✗	✗	✗	✓	✓
19	Read error I3	current I3 read error, on phase W	✗	✗	✗	✓	✓
20	Current imbalance	protection from high imbalance between the currents in the three phases (when imbalance > 5A)	✗	✗	✗	✓	✓
21	phase U current peak	Short circuit protection localized on phase U	✗	✗	✗	✓	✓
22	phase V current peak	Short circuit protection localized on phase V	✗	✗	✗	✓	✓
23	phase W current peak	Short circuit protection localized on phase W	✗	✗	✗	✓	✓
24	current leakage	protection in case of a high earth leakage current (> 5A)	✗	✗	✗	✓	✓
25	Fan 2 current peak	short circuit on NEO-22 output line 2 for single-phase fan	✗	✗	✗	✗	✓
26	Fan 1 current peak	short circuit on NEO-22 output line 1 for single-phase auxiliary fan	✗	✗	✗	✗	✓
27	Fan overcurrent	Overcurrent protection on NEO-22 output for single-phase auxiliary fan	✗	✗	✗	✗	✓
28	AN1 out of limit	signal <3mA when set on 4-20mA	✓	✓	✓	✓	✓
29	AN2 out of limit	signal <3mA when set on 4-20mA	✓	✓	✓	✓	✓
31	Minimum power	Alarm signal for power absorbed by the motor below the minimum percentage value set	✗	✗	✗	✓	✓

Table 7: Alarm Menu

✓ = activated alarm

✗ = not activated alarm

The restart after alarm must be preceded by a verification of the system, in order to find the reason of the alarm. Unconditioned restarts can lead to the product destruction and to a risk for the safety of the connected machines and the users.

The alarm can be reset by using the button STOP. If it returns, contact the technical service.



Compatibility table chart SW versions between Inverter and Keypad

		SW VERSION NEO-WiFi 3KW														
		2.03	2.04	2.05	2.06	2.07	3.01	3.02	3.03	3.04	3.05	3.06	4.02	4.04	4.08	4.11
SW VERSION KEYPAD NEO-WiFi	2.06	compatible	compatible	compatible	compatible	compatible										
	2.07	compatible	compatible	compatible	compatible	compatible										
	2.08	compatible	compatible	compatible	compatible	compatible										
	2.09	compatible	compatible	compatible	compatible	compatible										
	2.10	compatible	compatible	compatible	compatible	compatible										
	3.01						compatible	compatible	compatible	compatible	compatible	compatible				
	3.02						compatible	compatible	compatible	compatible	compatible	compatible				
	3.03						compatible	compatible	compatible	compatible	compatible	compatible				
	3.04						compatible	compatible	compatible	compatible	compatible	compatible				
	3.05						compatible	compatible	compatible	compatible	compatible	compatible				
	3.06						compatible	compatible	compatible	compatible	compatible	compatible				
	4.02												compatible			
	4.05													compatible		
	4.07													compatible		
4.08													compatible	compatible		
4.11													compatible	compatible		
4.12															compatible	

		SW VERSION NEO-WiFi 4KW			
		5.02	5.03		
SW VERSION KEYPAD NEO-WiFi	5.02	compatible			
	5.03		compatible		

		SW VERSION NEO-WiFi 5.5KW			
		5.02	5.03		
SW VERSION KEYPAD NEO-WiFi	5.02	compatible			
	5.03		compatible		

		SW VERSION NEO-WiFi 11KW																
		1.07	1.08	1.09	1.10	2.01	2.02	2.03	2.04	2.05	2.06	2.07	2.08	3.01	3.05	3.07	3.08	3.10
SW VERSION KEYPAD NEO-WIFI	2.06	compatible	compatible	compatible	compatible													
	2.07	compatible	compatible	compatible	compatible													
	2.08	compatible	compatible	compatible	compatible													
	2.09	compatible	compatible	compatible	compatible													
	2.10	compatible	compatible	compatible	compatible													
	3.01					compatible	compatible	compatible	compatible	compatible								
	3.02					compatible	compatible	compatible	compatible	compatible								
	3.03					compatible	compatible	compatible	compatible	compatible								
	3.04					compatible	compatible	compatible	compatible	compatible								
	3.05					compatible	compatible	compatible	compatible	compatible								
	3.06					compatible	compatible	compatible	compatible	compatible	compatible	compatible	compatible					
	4.02													compatible				
	4.05													compatible				
	4.07														compatible	compatible	compatible	
	4.08														compatible	compatible	compatible	
4.11														compatible	compatible	compatible	compatible	
4.12																compatible	compatible	

		SW VERSION NEO-WiFi 22KW			
		3.02	3.03		
SW VERSION KEYPAD NEO-WIFI	4.11	compatible	compatible		
	4.12	compatible	compatible		



To know the SW version of your keypad, press the button , the SW version will appear on the upper right of the display (in the example in the picture the SW version of the keypad would be 4.11). Do this operation **with the inverter switched off**.



To know the SW version of your NEO-WiFi, switch on the inverter and then the keypad by pressing the button . Wait a few seconds to allow the keypad to communicate with the inverter, when the inverter goes in communication with the keypad, the POWER led lights up. The SW version of the inverter will appear on the upper right of the display (in the example shown in the picture, the SW version of the NEO-WiFi-3 would be 4.08).



6h. MODBUS

MODBUS works from
 NEO-WiFi-3 version 3.01
 NEO-WiFi-11 version 2.01
 NEO-WiFi-22 version 3.02
 KEYPAD version 3.01



MODBUS protocol is connected to NEO-WiFi by using the RS-485 port:

NEO-WiFi-3 at pins A and B of terminal J9

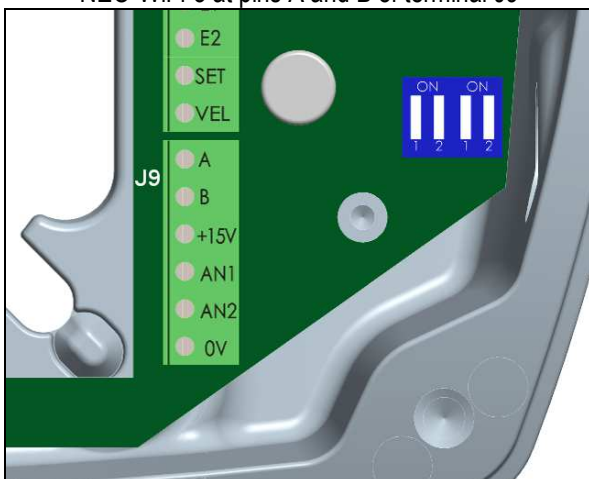

NEO-WiFi-11/22 at pins A and B of terminal J9

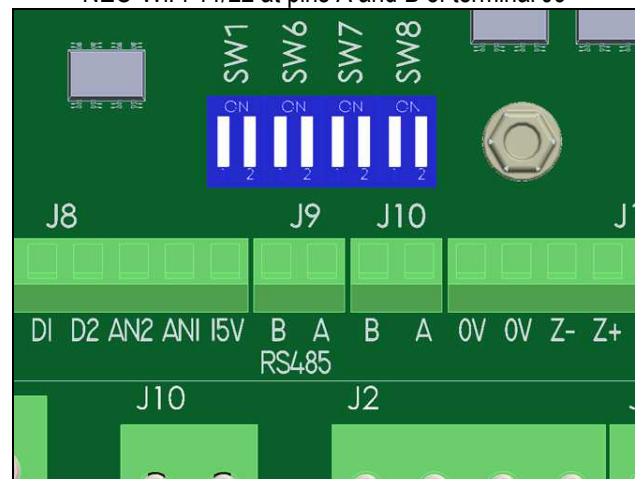

MODBUS communication can be controlled by:



A. SMARTPHONE/TABLET

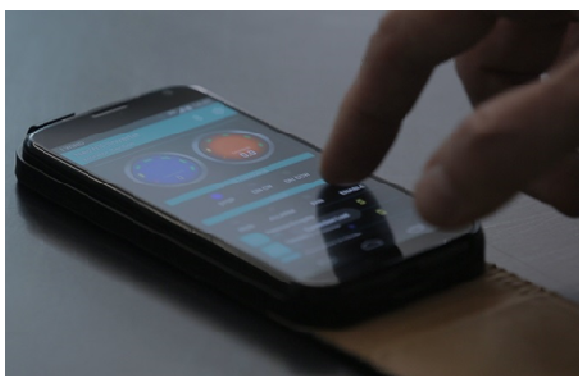

BLUE



It's necessary to connect Motive Bluetooth module at NEO modbus terminals
(see par. 5d.2 Bluetooth module mounting)



1. Go to "App Store" or "Play Store"
2. Digit "Motive Inverter NEO"





3. Click on "NEO" icon
4. Start to use it

Motive NEO APP is automatically set in Italian or English (for all non-Italian users) depending by the settings of your smartphone/tablet.

You can now set the modbus communication (Modbus Section), program it (Parameters Section), set automatic start/stop (Timer Section, only for NEO-WiFi-11 and NEO-WiFi-22), command it (Commands Section) and monitor the functioning (Monitor Section).

NEO 1- Monitor Section

Rotation Direction

STOP
 ON CW
 ON CCW

Inverter Status

MOTOR
 ALARM
 FAN
 POWER

81	Power Output [W]	R	118
83	Output Voltage [V]	R	165
87	Output Frequency [Hz]	R	40.3
84	Power Module Temperature [°C]	R	26
85	Power Factor cos(φ)	R	0.47
32	Last Recorded Alarm	R	80

NEO 2- Commands Section

Rotation



106	Speed [RPM]	R/W	1180
107	Position [n.pulses]	R/W	0
109	Acceleration [seconds]	R/W	0.5
110	Deceleration [seconds]	R/W	0.5

NEO

3- Parameters Section

Commands Origin

Keypad Btn+Select
 Keypad
 Remote

Speed Signal Origin

Internal Speed
 Keypad Potentiometer
 AN2 External Potentiometer
 AN1 0-10V
 AN1 4-20mA

Various Settings

Enable Electromagnetic Brake
 Enable Automatic Restart
 Enable Encoder Feedback
 T_R_Fault Stop

Motor Data

6	Rated Power [kW]	R/W	0.37
7	Rated Voltage [V]	R/W	230
8	Rated Current [A]	R/W	2
9	Rated Frequency [Hz]	R/W	50
10	Rated RPM [rpm]	R/W	1366
11	Rated Power Factor cos(φ)	R/W	0.72
38	Magnetization [%]	R/W	100

Application Data

13	Maximum Speed [%of motor synchronous speed]	R/W	200
14	Minimum Speed [%of motor synchronous speed]	R/W	2
15	Acceleration [seconds]	R/W	0.5
16	Deceleration [seconds]	R/W	0.5
17	Maximum Inrush Current [%in]	R/W	150
18	Rotation Direction from Keypad	R/W	1
19	Internal Speed [rpm]	R/W	2732
21	Voltage Feed of the Brake Coil [0=104V 1=180V]	R/W	0
24	Dead Time after Alarm [seconds]	R/W	5
27	Encoder pulses/revolution integer [pulses/revolution]	R/W	1024
28	Encoder pulses/revolution decimal [pulses/revolution/1000]	R/W	0
30	Proportional Factor	R/W	25
31	Integral Factor	R/W	25

NEO 4- Timer Section

Inveter Date and Time

25-Gen-2000 08:47:25

Enable Timer Function

36	Time Setting [seconds]	R/W	
44	Start Instant[0] [minutes]	R/W	
45	Stop Instant[0] [minutes]	R/W	
46	Start Instant[1] [minutes]	R/W	
47	Stop Instant[1] [minutes]	R/W	
48	Start Instant[2] [minutes]	R/W	
49	Stop Instant[2] [minutes]	R/W	
50	Start Instant[3] [minutes]	R/W	
51	Stop Instant[3] [minutes]	R/W	
52	Start Instant[4] [minutes]	R/W	
53	Stop Instant[4] [minutes]	R/W	

NEO 5- Modbus Section

Modbus Communication

OFF ON + Key ON

BaudRate [bit/s]

4800 9600 14400 19200

Device BaudRate [bit/s]

9600 19200

BLE Device Name

BLUE

22	Modbus Machine Code	R/W	
56	Factory Reset	R/W	

B. PLC, using parameters reported in “NEO Modbus Parameters” chart.

C. PC, downloading the "Motive Motor Manager" (Chapter 7) interface with Motive USB-RS485 converter:

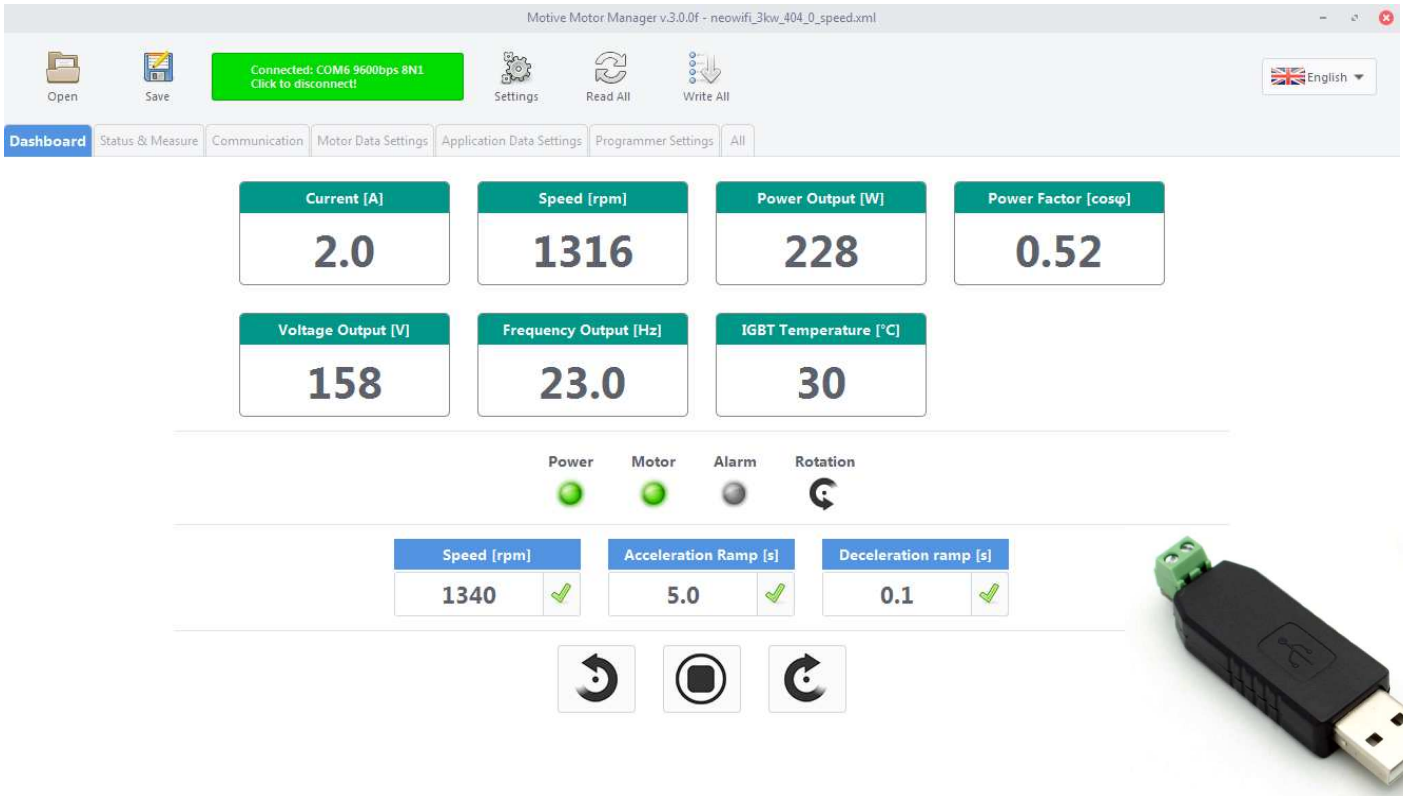

Connection USB-RS485 converter to the inverter (do this operation with not powered inverter!):

NEO-WiFi-3 at pins A and B of terminal J9

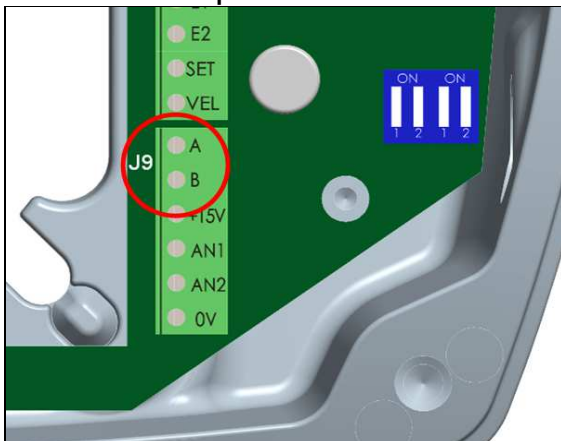

NEO-WiFi-11/22 at pins A and B of terminal J9

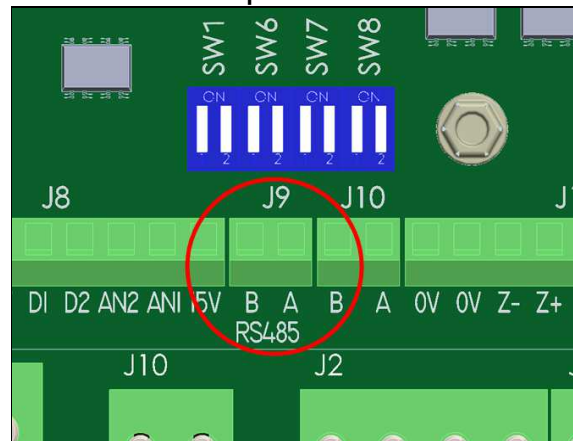

USB-RS485 converter is automatically installed on PC. If this doesn't happen, download the driver at the following link:
https://www.motive.it/upload/documenti/software/USB-RS485_Driver.zip

7. MOTIVE MOTOR MANAGER

7a. Download and installation



Download PC interface “Motive Motor Manager” at following link:
<https://www.motive.it/upload/documenti/software/MotiveMotorManager.zip>

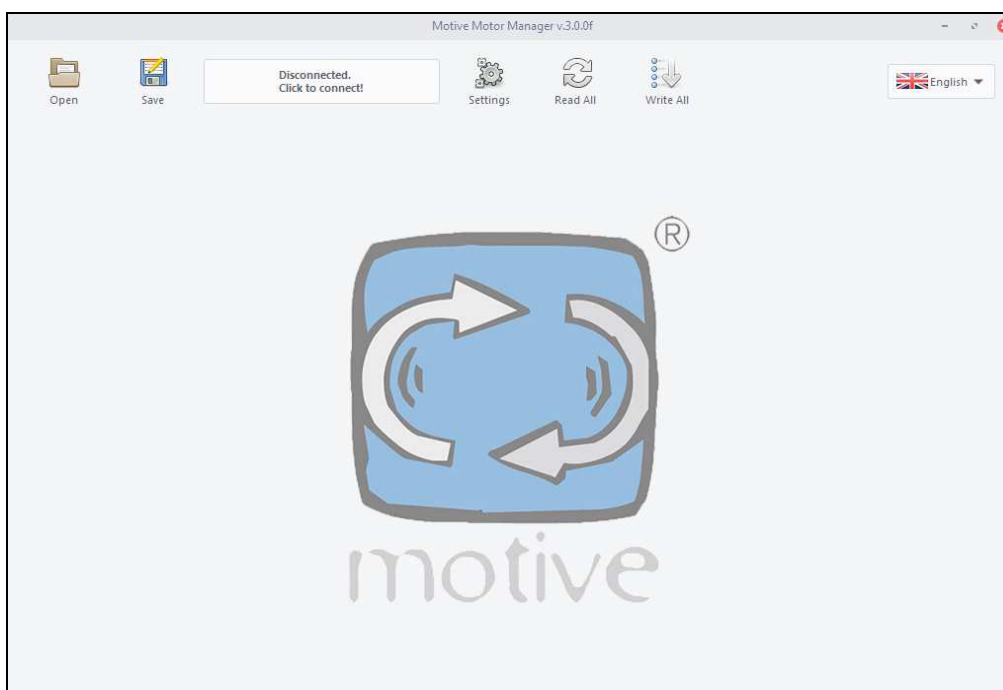

System requirements:

Windows 7-8-10, Windows Server 2003-2008-2016
USB port
NET Framework 3.5 or next

Software installation:

Download the SW. Save the zip file on the desktop
Please install the program using the executable file “installer.exe”. To run the program is recommended to log as administrator.

Please follow the instructions till the end of this procedure.

At the end of the installation you will find a new icon  on your desktop.
Click on the icon to run the program.

Switch on the inverter.

Choose the language in the drop-down menu at the top right.



7b. USB-RS485 Converter connection settings



Click on the icon **Settings** to set the correct USB port to which the inverter is connected. At the end, click “Apply”.

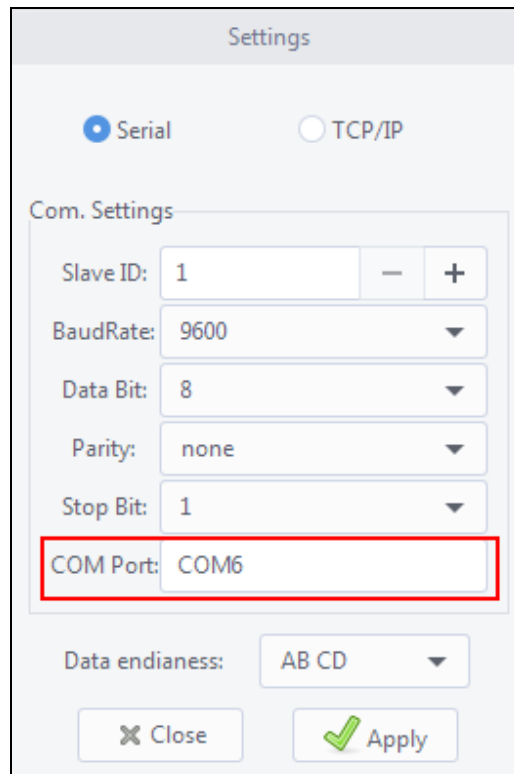

The image shows a 'Settings' dialog box with two radio buttons: 'Serial' (selected) and 'TCP/IP'. Under 'Com. Settings', there are several fields: 'Slave ID' (1), 'BaudRate' (9600), 'Data Bit' (8), 'Parity' (none), and 'Stop Bit' (1). The 'COM Port' field is highlighted with a red box and contains 'COM6'. Below these fields is a 'Data endianness' dropdown set to 'AB CD'. At the bottom are 'Close' and 'Apply' buttons.

Then click on “Click to connect!” to communicate with NEO.
If the USB port has been correctly set, the bar will turn green (the device is connected to the PC).

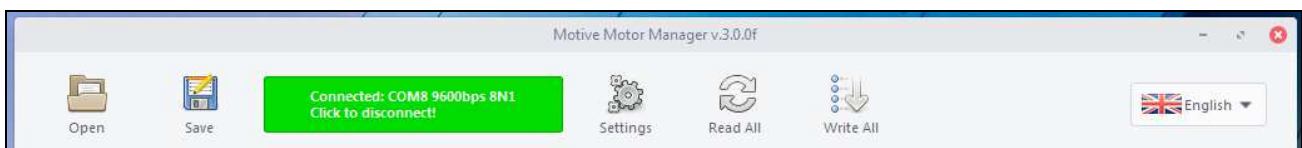

If not, the bar will turn red (the device is not connected to the PC).

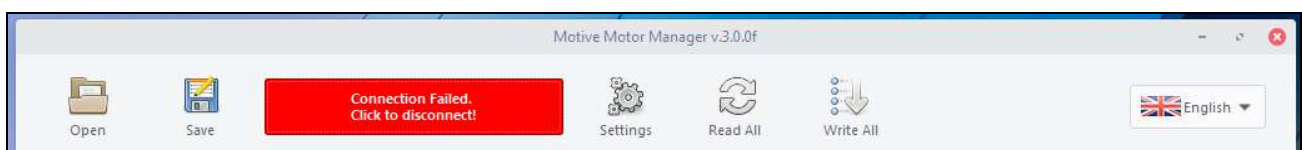

Once the device is connected to the PC, Motive Motor Manager recognizes the inverter and automatically loads the default parameter list.

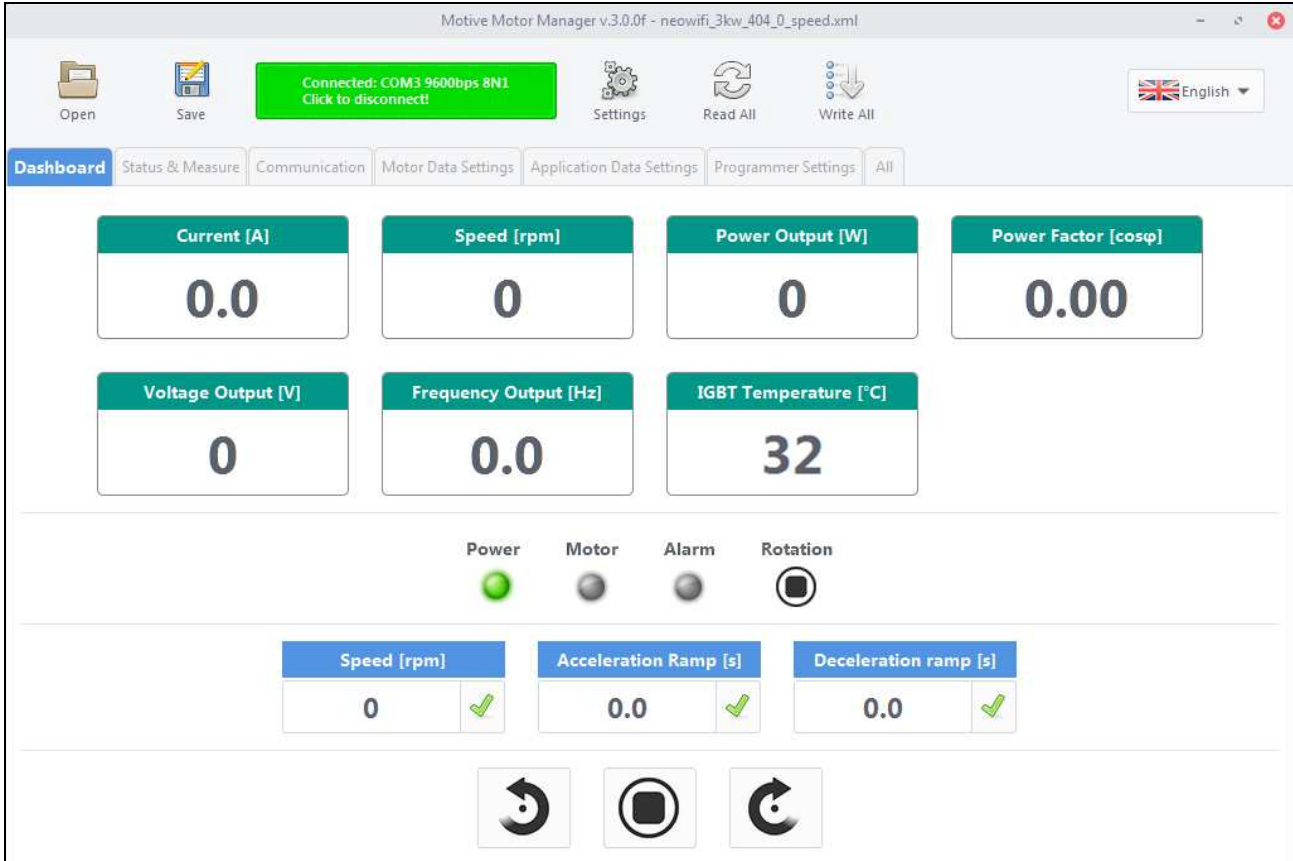

7c. Main functions

The program consists of 7 sheets:

- **Dashboard**, where you can control the main measured values, change the speed, the rotation and start/stop the motor manually;

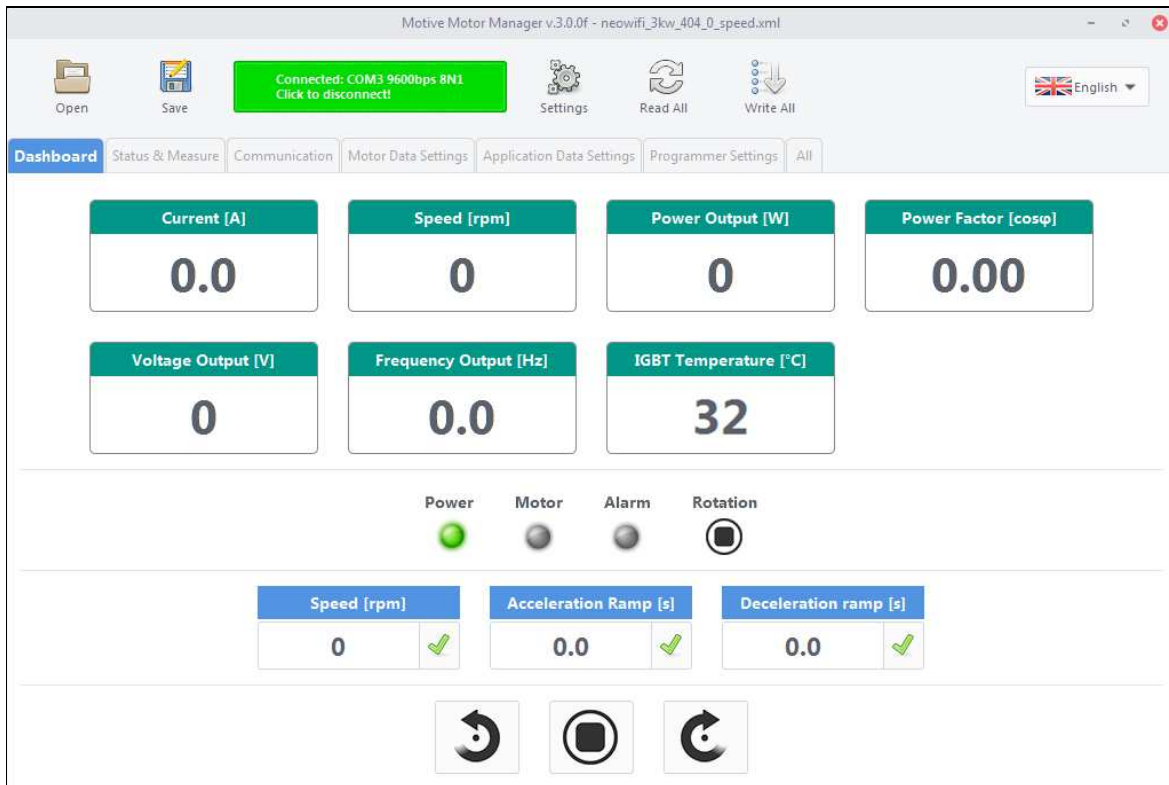

- **Status&Measure**, where you can see all the measured values;

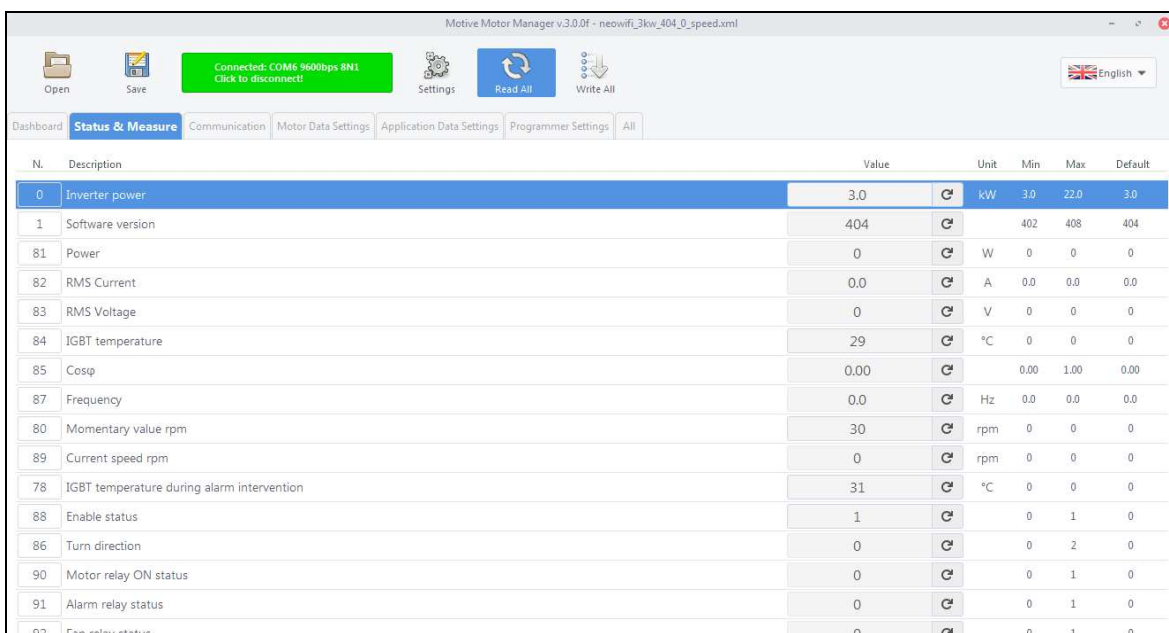

N.	Description	Value	Unit	Min	Max	Default
0	Inverter power	3.0	kW	3.0	22.0	3.0
1	Software version	404		402	408	404
81	Power	0	W	0	0	0
82	RMS Current	0.0	A	0.0	0.0	0.0
83	RMS Voltage	0	V	0	0	0
84	IGBT temperature	29	°C	0	0	0
85	Cosφ	0.00		0.00	1.00	0.00
87	Frequency	0.0	Hz	0.0	0.0	0.0
80	Momentary value rpm	30	rpm	0	0	0
89	Current speed rpm	0	rpm	0	0	0
78	IGBT temperature during alarm intervention	31	°C	0	0	0
88	Enable status	1		0	1	0
86	Turn direction	0		0	2	0
90	Motor relay ON status	0		0	1	0
91	Alarm relay status	0		0	1	0
92	Fan relay status	0		0	1	0

- **Communication**, where you can enable/disable the Modbus communication and control (for programming and controlling inverter by Modbus, set parameter 40 "Modbus communication" =2);

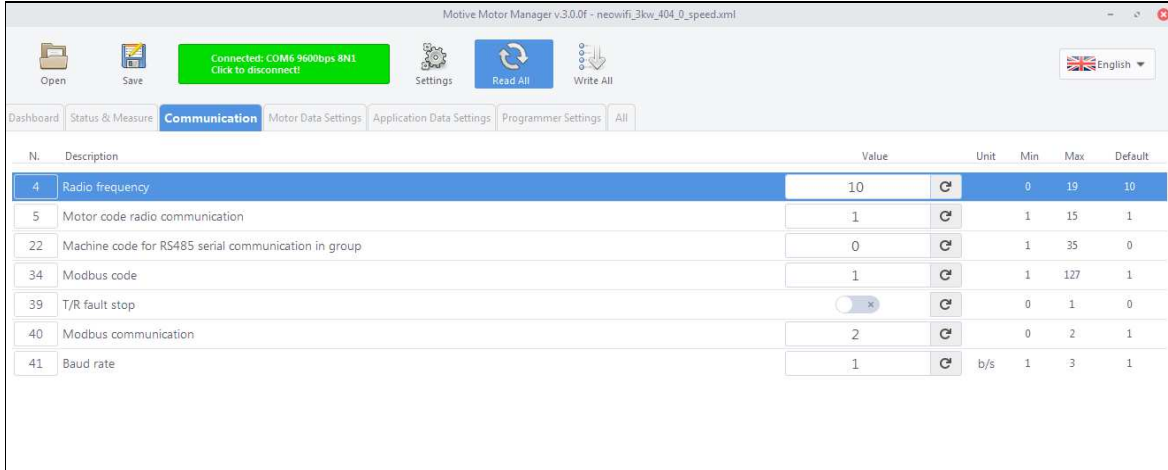

N.	Description	Value	Unit	Min	Max	Default
4	Radio frequency	10		0	19	10
5	Motor code radio communication	1		1	15	1
22	Machine code for RS485 serial communication in group	0		1	35	0
34	Modbus code	1		1	127	1
39	T/R fault stop	<input checked="" type="checkbox"/>		0	1	0
40	Modbus communication	2		0	2	1
41	Baud rate	1	b/s	1	3	1

- **Motor Data Settings**, where you can insert the data from the data plate and set the motor performances;

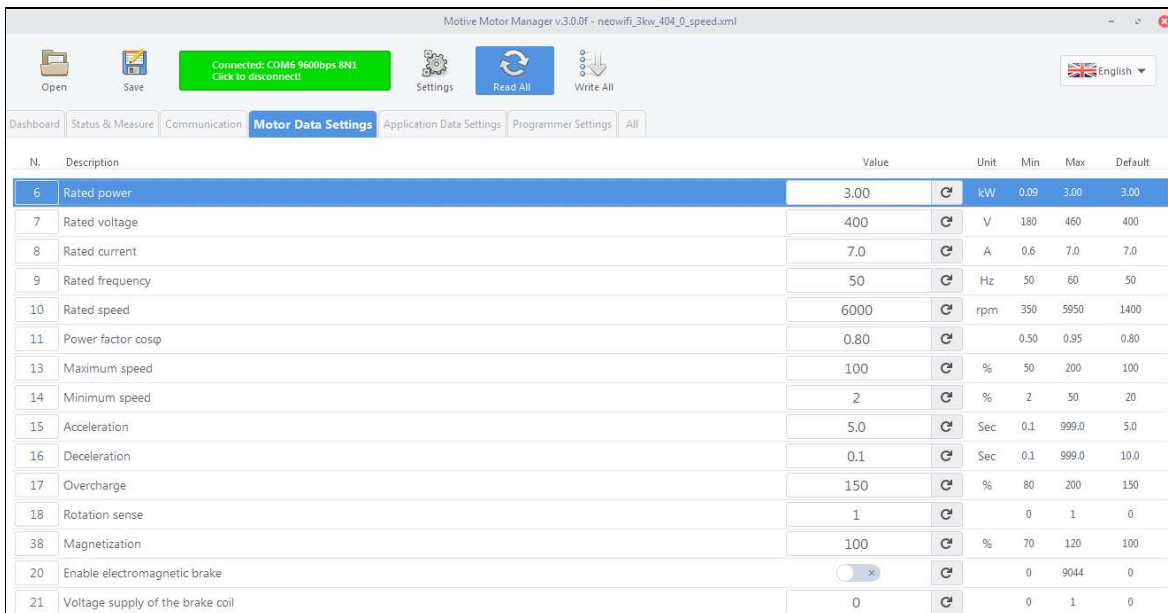

N.	Description	Value	Unit	Min	Max	Default
6	Rated power	3.00	kW	0.09	3.00	3.00
7	Rated voltage	400	V	180	460	400
8	Rated current	7.0	A	0.6	7.0	7.0
9	Rated frequency	50	Hz	50	60	50
10	Rated speed	6000	rpm	350	5950	1400
11	Power factor cosφ	0.80		0.50	0.95	0.80
13	Maximum speed	100	%	50	200	100
14	Minimum speed	2	%	2	50	20
15	Acceleration	5.0	Sec	0.1	999.0	5.0
16	Deceleration	0.1	Sec	0.1	999.0	10.0
17	Overcharge	150	%	80	200	150
18	Rotation sense	1		0	1	0
38	Magnetization	100	%	70	120	100
20	Enable electromagnetic brake	<input checked="" type="checkbox"/>		0	9044	0
21	Voltage supply of the brake coil	0		0	1	0

- **Application Data Settings**, where it is possible to configure the control mode, the I/ O module and other functions;

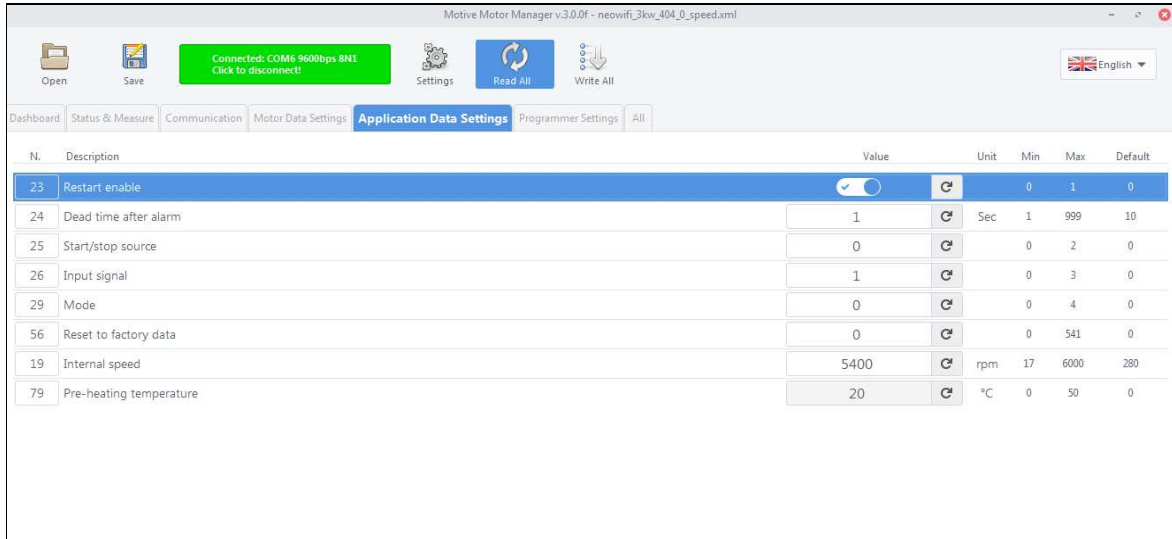

N.	Description	Value	Unit	Min	Max	Default
23	Restart enable	<input checked="" type="checkbox"/>		0	1	0
24	Dead time after alarm	1	Sec	1	999	10
25	Start/stop source	0		0	2	0
26	Input signal	1		0	3	0
29	Mode	0		0	4	0
56	Reset to factory data	0		0	541	0
19	Internal speed	5400	rpm	17	6000	280
79	Pre-heating temperature	20	°C	0	50	0

- **Programmer Settings**, where it's possible to set up to four inverter programmed switching on and off (function available only for NEO11 and NEO22);

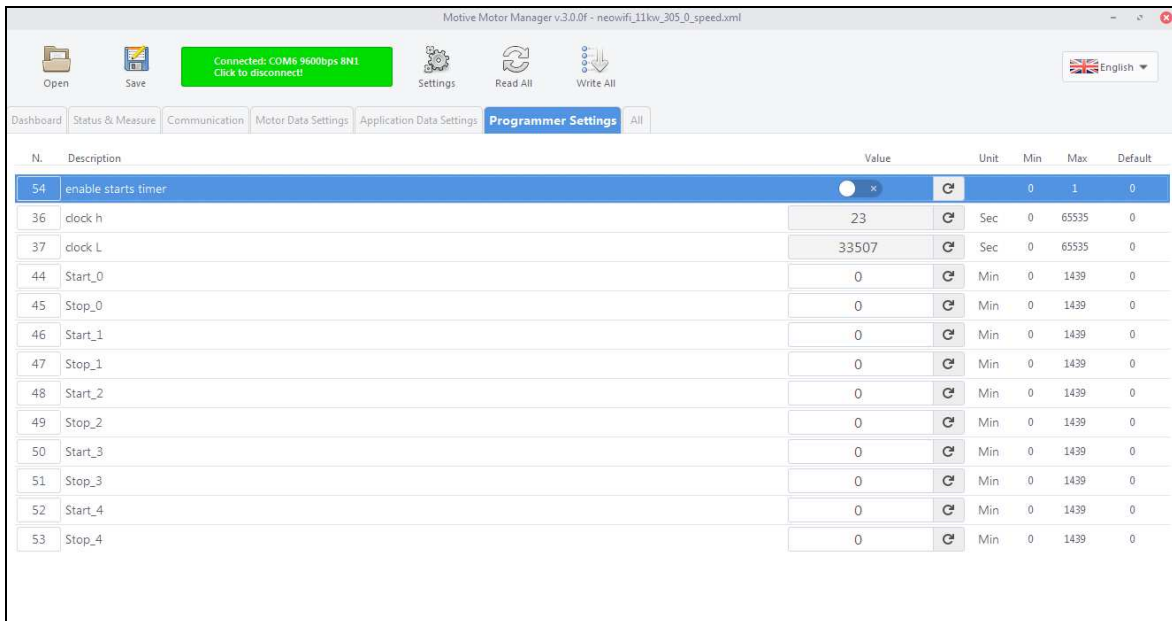

N.	Description	Value	Unit	Min	Max	Default
54	enable starts timer	<input type="checkbox"/>		0	1	0
36	clock h	23	Sec	0	65535	0
37	clock L	33507	Sec	0	65535	0
44	Start_0	0	Min	0	1439	0
45	Stop_0	0	Min	0	1439	0
46	Start_1	0	Min	0	1439	0
47	Stop_1	0	Min	0	1439	0
48	Start_2	0	Min	0	1439	0
49	Stop_2	0	Min	0	1439	0
50	Start_3	0	Min	0	1439	0
51	Stop_3	0	Min	0	1439	0
52	Start_4	0	Min	0	1439	0
53	Stop_4	0	Min	0	1439	0

- **All**, where you can find the complete list of parameters in numerical order.

Motive Motor Manager v.3.0.0f - neowifi_3kw_404_0_speed.xml

Open Save **Connected: COM5 9600bps #N1** Click to disconnect! Settings Read All Write All English

Dashboard Status & Measure Communication Motor Data Settings Application Data Settings Programmer Settings **All**



N.	Description	Value	Unit	Min	Max	Default
0	Inverter power	3.0	kW	3.0	22.0	3.0
1	Software version	404		402	408	404
4	Radio frequency	10		0	19	10
5	Motor code radio communication	1		1	15	1
6	Rated power	3.00	kW	0.09	3.00	3.00
7	Rated voltage	400	V	180	460	400
8	Rated current	7.0	A	0.6	7.0	7.0
9	Rated frequency	50	Hz	50	60	50
10	Rated speed	6000	rpm	350	5950	1400
11	Power factor cosφ	0.80		0.50	0.95	0.80
13	Maximum speed	100	%	50	200	100
14	Minimum speed	2	%	2	50	20
15	Acceleration	5.0	Sec	0.1	999.0	5.0
16	Deceleration	0.1	Sec	0.1	999.0	10.0
17	Overcharge	150	%	80	200	150
18	Rotation sense	1		0	1	0

7d. Reading and writing parameters

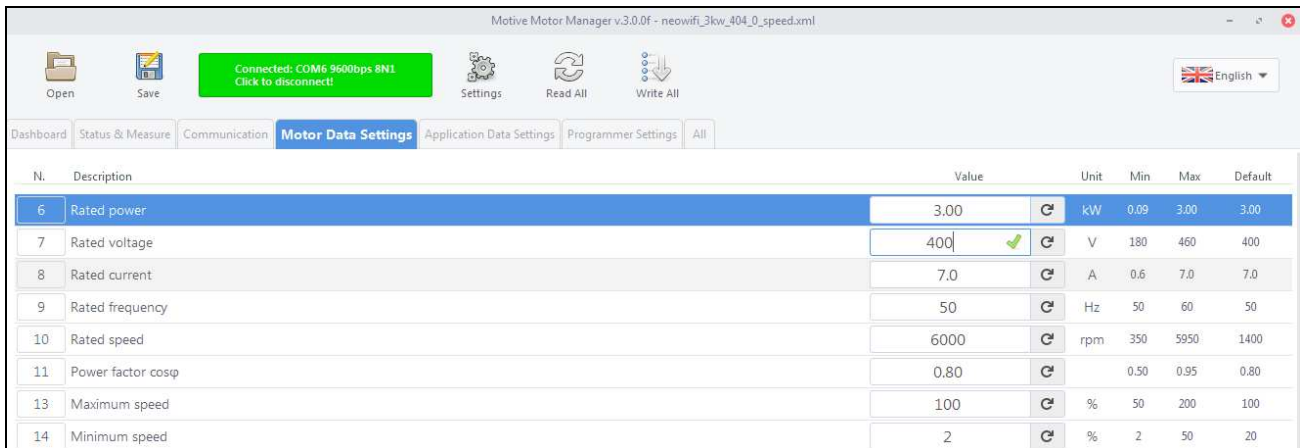
To change or write a new parameter value, write to the data bar and click  .



N.	Description	Value	Unit	Min	Max	Default
6	Rated power	3.00	kW	0.09	3.00	3.00
7	Rated voltage	400 	V	180	460	400
8	Rated current	7.0	A	0.6	7.0	7.0
9	Rated frequency	50	Hz	50	60	50
10	Rated speed	6000	rpm	350	5950	1400
11	Power factor cosp	0.80		0.50	0.95	0.80
13	Maximum speed	100	%	50	200	100
14	Minimum speed	2	%	2	50	20

If the value written is correct (it means that the value is between the minimum and maximum limits set), the data bar will turn green for a short moment  ; if not, it will turn red  .

With the icons  **Read All** and  **Write All** all parameters can be read and written at once.

With the icon  **Save** you can save a copy of the parameter list customized by the user, which can be uploaded later using

the icon  **Open** .

Modbus Variables table chart

NEO-WiFi Modbus Variables (Rev. 16/12/2016)

This modbus table chart is installed in the following inverter SW versions:

NEO3 → 4.02 – 4.04 – 4.08

NEO11 → 3.01 – 3.05

NOTE: Not all the variables can be modified. In the column "Type" the letter R means "read only" and R/W means "Read and Write"

N°	Type	Variable Definition	UOM	Lower Limit	Upper Limit	Note
0	R	inverter power	KW*10	30	220	
1	R	software version				
2	R	last revision (day+month*32+year*32*13)	days	0	0xffff	
3						
4	R/W	radio frequency-860	Mhz-860	0	19	connect SET with +15V (NEO3) / 0V (NEO11-22)
5	R/W	motor code radio communication		1	15	connect SET with +15V (NEO3) / 0V (NEO11-22)
6	R/W	rated power	KW*100	9	2200	the value range, depends on the inverter type
7	R/W	rated voltage	V	180	460	
8	R/W	rated current	A*10	6	450	the value range, depends on the inverter type
9	R/W	rated frequency	Hz	50	60	
10	R/W	rated rpm	rpm	350	5950	
11	R/W	power factor cosφ	*100	50	95	
12						
13	R/W	maximum speed	% of motor speed	50	200	
14	R/W	minimum speed	% of motor speed	2	50	
15	R/W	acceleration	seconds*10	1	999	
16	R/W	deceleration	seconds*10	1	999	
17	R/W	maximum inrush current	%In	80	200	NEO 3 KW: 150% NEO 11 KW: 200% (7,5kW) 160% (11kW) Max NEO 22 KW: 150%
18	R/W	rotation sense (valid with start/stop commands)		0	1	valid only when the start/stop source, is from keypad without selector
19	R/W	internal speed	rpm	minimum speed	maximum speed	
20	R/W	enable electromagnetic brake		0	9044	0=OFF, 9044=ON Before connecting the wires of the external braking resistances to the BR + and BR- terminals, disconnect from the same terminals the wires of the internal resistances and insulate them.
21	R/W	voltage feed of the brake coil	V	(104V) 0	(180V) 1	
22	R/W	machine code for RS485 serial communication in group		1	35	See following tablechart***
23	R/W	enable restart		0	1	0=OFF, 1=ON
24	R/W	dead time after alarm	seconds	1	999	restart after alarm
25	R/W	start/stop source		0	2	0 = keypad button and keypad selector 1 = keypad button only 2 = External remote wired control
26	R/W	speed reference		0	4	0=internal speed 1=keypad potentiometer 2=AN1 signal 0-10V 3=AN1 signal 4-20mA 4=AN2 signal 0-5V (only in speed control)
27	R/W	encoder pulses/revolution integer	pulses/revolution	0	9999	
28	R/W	encoder pulses/revolution decimal	pulses/revolution/1000	0	999	



29	R/W	Control mode		0	4	0 = Speed; 1 = Speed+Encoder; 2 = Ventilation; 3 = Compressor; 4 = HP Pump.
30	R/W	proportional factor		0	100	
31	R/W	integral factor		0	100	
32	R	last alarm recorded		0	6539	
33	R/W	Braking Joules	J/100	1	127	
34	R/W	Modbus code		1	127	Inverter code in Modbus communication
35	R/W	Stop power for dry operation stop	%Pn	20	100	
36	R/W	clock h	seconds*0x10000	0	0xffff	To calculate follow this calculation: minutes * 60= result result + (Hour * 60 * 60)= result 1 result 1 + (Day * 60 * 60 * 24)= result 2 result 2 + (Month * 60 * 60 * 24 * 32) =result 3 result 3 + (Year * 60 * 60 * 24 * 32 * 13) =result 4 For the year write only the last two digits, for example 2014 must be 14 result 4 /65536= clock h without decimals If there are problems during calculation, please download the spreadsheet automatically from www.motive.it
37	R/W	clock l	seconds	0	0xffff	To calculate follow this calculation: minutes * 60= result result + (Hour * 60 * 60)= result 1 result 1 + (Day * 60 * 60 * 24)= result 2 result 2 + (Month * 60 * 60 * 24 * 32) =result 3 result 3 + (Year * 60 * 60 * 24 * 32 * 13) =result 4 For the year write only the last two digits, for example 2014 must be 14 result 4 / 65536 = clock h without decimals result 4 – (clock h*65536) = clock l without decimals If there are problems during calculation, please download the spreadsheet automatically from www.motive.it
38	R/W	magnetization	%	80	120	
39	R/W	T R fault stop		0	1	0=OFF, 1=ON; When this function is ON, it switches off the motor if: -The T/R radio communication between keypad and NEO is missing for more than 5 seconds; -The modbus communication (Variable 40=2) loses the signal from serial port RS485;
40	R/W	modbus communication		1	2	0 =OFF, 1=ON+KEY, 2=ON OFF = programming and operation only from keypad ON+KEY = programming from modbus and operation from keypad (External remote wired control/speed signal are included), ON=motor is commanded by Modbus ON = programming and operation only from modbus
41	R/W	baud rate	bit/s	0	3	0 = 4800 1 = 9600 (Default) 2 = 14400 3 =19200 bit/s
42	R	status rotation		0	2	It's the position set on selector, received from the keyboard 0=OFF 1=direction 1 2=direction 2
43						

44	R/W	start [0]	minutes	0	1439	to calculate the value: hours*60+minutes (if there are problems during calculation, please download the spreadsheet automatically from www.motive.it)
45	R/W	stop [0]	minutes	0	1439	to calculate the value: hours*60+minutes (if there are problems during calculation, please download the spreadsheet automatically from www.motive.it)
46	R/W	start [1]	minutes	0	1439	to calculate the value: hours*60+minutes (if there are problems during calculation, please download the spreadsheet automatically from www.motive.it)
47	R/W	stop [1]	minutes	0	1439	to calculate the value: hours*60+minutes (if there are problems during calculation, please download the spreadsheet automatically from www.motive.it)
48	R/W	start [2]	minutes	0	1439	to calculate the value: hours*60+minutes (if there are problems during calculation, please download the spreadsheet automatically from www.motive.it)
49	R/W	stop [2]	minutes	0	1439	to calculate the value: hours*60+minutes (if there are problems during calculation, please download the spreadsheet automatically from www.motive.it)
50	R/W	start [3]	minutes	0	1439	to calculate the value: hours*60+minutes (if there are problems during calculation, please download the spreadsheet automatically from www.motive.it)
51	R/W	stop [3]	minutes	0	1439	to calculate the value: hours*60+minutes (if there are problems during calculation, please download the spreadsheet automatically from www.motive.it)
52	R/W	start [4]	minutes	0	1439	to calculate the value: hours*60+minutes (if there are problems during calculation, please download the spreadsheet automatically from www.motive.it)
53	R/W	stop [4]	minutes	0	1439	to calculate the value: hours*60+minutes (if there are problems during calculation, please download the spreadsheet automatically from www.motive.it)
54	R/W	enable starts timer		0	1	0=OFF 1=ON
55	R/W	save parameter		0	65535	to save the parameter, write 1 and next 541 (wait until it returns to 0 to confirm receipt)
56	R/W	reset factory data		0	65535	to reset the factory data write 1 (Standard) or 2 (Ventilation) or 3 (Compressors) or 4 (HP pumps), and then 541 (wait until it returns to 0 to confirm receipt)
57	R/W	sensor min setting	mA*10	10	120	
58	R/W	sensor max setting	mA*10	50	300	
59	R/W	pressure read range	bar*1000 (Ventilation) bar*100 (Compressor) bar*10 (HP Pump)	69	16000	
60	R/W	pressure internal reference	bar*1000 (Ventilation) bar*100 (Compressor) bar*10 (HP Pump)	69	PAR.59	
61	R/W	pressure hysteresis	bar*1000 (Ventilation) bar*100 (Compressor) bar*10 (HP Pump)	1	200	
62	R/W	Time for stop when pressure is reached	s	1	300	

63	R/W	alarm saved		0	6539	show the last alarm saved, or the alarm corresponding to the number written
64	R	alarm type		1	29	
65	R	time intervention alarm h	s*0x10000	0	0xffff	
66	R	time intervention alarm l	s	0	0xffff	
67	R	voltage during alarm intervention[V12]	V	-	-	
68	R	voltage during alarm intervention[V13]	V	-	-	
69	R	voltage during alarm intervention[V23]	V	-	-	
70	R	current during alarm intervention[I1]	A*10	-	-	
71	R	current during alarm intervention[I2]	A*10	-	-	
72	R	current during alarm intervention[I3]	A*10	-	-	
73	R	power during alarm intervention	W	-	-	
74	R	voltage capacitors during alarm intervention	Vdc	-	-	
75	R	frequency during alarm intervention	Hz	-	-	
76	R	power factor during alarm intervention	*100	-	-	
77	R	rpm during alarm intervention	rpm	-	-	
78	R	IGBT temperature during alarm intervention	°C	-	-	
79	R	pre-heating temperature	°C	0	50	
80	R	momentary value RPM/bar	RPM (speed) bar*1000 (Ventilation) bar*100 (Compressor) bar*10 (HP Pump)	-	-	average value measured in about 0,5s
81	R	power	W	-	-	average value, measured in about 0.5s
82	R	I rms	A*10	-	-	average value, measured in about 0.5s
83	R	V rms	V	-	-	average value, measured in about 0.5s
84	R	IGBT temperature	°C	-	-	average value, measured in about 0.5s
85	R	cosfi	*100	-	-	average value, measured in about 0.5s
86	R	current turn direction		0	2	0 = OFF 1 = direction 1 2 = direction 2 with or without keypad selector
87	R	frequency Hz	Hz*10	-	-	
88	R	enable status		0	1	0 = OFF 1 = ON
89	R	current speed RPM/bar	RPM (speed) bar*1000 (Ventilation) bar*100 (Compressor) bar*10 (HP Pump)	-	-	reference value from keypad potentiometer or AN2 potentiometer or AN1 signal. (it depends on control mode 29 and machine code mode 56).
90	R	motor relay ON status		0	1	0 = OFF 1 = ON
91	R	alarm relay status		0	1	0 = OFF 1 = ON
92	R	fan relay status		0	1	0 = OFF 1 = ON
93	R	diagnostics inverter		0		16-bit register with all status bits (download the table from www.motive.it)
94	R	communication events		0	65535	
95	R/W	error counter CRC		0	0xffff	
96	R/W	error counter exception		0	0xffff	
97	R/W	counter messages received		0	0xffff	
98	R/W	counter messages received without reply		0	0xffff	
99	R/W	counter messages NAK		0	0xffff	
100	R/W	counter messages with slave occupied		0	0xffff	
101	R/W	counter messages overrun		0	0xffff	



102	R	Pressure reference received	bar*1000	0	16000	from keypad or external remote wired controls
103	R/W	Pressure max limit	bar*1000	10	16000	
104						
105	R/W	modbus command rotation		0	2	0 = OFF 1 = ON Direction 2 = ON Direction 2
106	R/W	command_modbus_RPM/bar*1000	RPM (speed) bar*1000 (Ventilation) bar*100 (Compressor) bar*10 (HP Pump)	0 (Speed) 69 (Pressure)	6000 (Speed) 16000 (Pressure)	
107	R/W	modbus command position h	n.pulses*0x10000	0	0xffff	encoder pulses/revolution integer
108	R/W	modbus command position l	n.pulses	0	0xffff	encoder pulses/revolution decimal
109	R/W	modbus command acceleration	second*10	1	999	
110	R/W	modbus command deceleration	second*10	1	999	
111	R/W	enable new modbus command		0	1	with the value 1 the variable from 105 to 110 are enabled (R/W)

***Register table chart 22 - machine code for RS485 serial communication in group:

		N° inverters quantity							
		1	2	3	4	5	6	7	8
N° inverter	1	0	1	2	3	4	5	6	7
	2		8	9	10	11	12	13	14
	3			15	16	17	18	19	20
	4				21	22	23	24	25
	5					26	27	28	29
	6						30	31	32
	7							33	34
	8								35



NEO-WiFi Modbus Variables (Rev. 07/11/2017)

This modbus table chart is installed in the following inverter SW versions:

NEO3 → 4.11

NEO11 → 3.07 – 3.08 – 3.10

NEO22 → 3.02 – 3.03

NOTE: Not all the variables can be modified. In the column "Type" the letter R means "read only" and R/W means "Read and Write"

N°	Type	Variable definition	u.o.m	Min. Limit	Max. Limit	Notes
0	R	inverter power	KW*10	30	220	
1	R	software version				
2	R	last revision(day+month*32+year*32*13)	days	0	0xffff	
3						
4	R/W	radio frequency-860	Mhz-860	0	19	Connect SET to +15V (NEO3) / 0V (NEO11-22)
5	R/W	code motor radio communication		1	127	
6	R/W	rated power	KW*100	9	2200	the value range depends on the inverter type
7	R/W	rated voltage	V	180	460	
8	R/W	rated current	A*10	6	450	the value range depends on the inverter type
9	R/W	rated frequency	Hz	50	60	
10	R/W	rated rpm	rpm	350	5950	
11	R/W	power factor cosφ	*100	50	95	
12						
13	R/W	maximum speed	% of rated speed	2	200	
14	R/W	minimum speed	% of rated speed	2	120	the value range depends on the inverter type
15	R/W	acceleration	seconds*10	1	999	
16	R/W	deceleration	seconds*10	1	999	
17	R/W	maximum inrush current	%In	100	200	the value range depends on the inverter type
18	R/W	rotation sense		0	1	enabled only when the start/stop source is from keypad without selector
19	R/W	internal speed	rpm	min speed	max speed	
20	R/W	enable electromagnetic brake		0	65535	0=OFF, 9044=ON (safety code) Before connecting the wires of the external braking resistances to the BR + and BR- terminals, disconnect from the same terminals the wires of the internal resistances and insulate them.
21	R/W	braking voltage	V	(104Vdc) 0	(180Vdc) 1	
22	R/W	machine code for RS485 serial communication group		1	35	***See following label chart
23	R/W	enable restart		0	1	0=OFF, 1=ON
24	R/W	dead time after alarm	seconds	1	999	restarting time after alarm
25	R/W	start/stop source		0	2	0=keypad button and keypad selector 1=keypad button 2=external remote wired control
26	R/W	speed reference		0	4	0=internal speed 1=keypad potentiometer 2=AN1 signal 0-10V 3=AN1 signal 4-20mA 4=AN2 signal 0-5V (only in speed control)
27	R/W	encoder pulses/revolution integer part	pulses/revolution	0	9999	
28	R/W	encoder pulses/revolution decimal part	pulses/revolution/1000	0	999	
29	R/W	control mode		0	2	0=Open loop speed 1=Speed+Encoder 2= Ventilation 3=Air compressor 4=HP pump
30	R/W	proportional factor		0	100	



31	R/W	integral factor		1	100	
32	R	last alarm recorded		0	6539	
33	R/W	braking joules	J/100	1	127	
34	R/W	modbus code		1	127	
35	R/W	stop power for dry operation	%Pn	20	100	
36	R	clock_h	seconds*0x10000	0	0xffff	To calculate follow this calculation: minutes * 60= result result + (Hour * 60 * 60)= result 1 result 1 + (Day * 60 * 60 * 24)= result 2 result 2 + (Month * 60 * 60 * 24 * 32) =result 3 result 3 + (Year * 60 * 60 * 24 * 32 * 13) =result 4 For the year write only the last two digits, for example 2014 must be 14 result 4 /65536= clock h without decimals If there are problems during calculation, please download the spreadsheet automatically from www.motive.it
37	R	clock_l	seconds	0	0xffff	To calculate follow this calculation: minutes * 60= result result + (Hour * 60 * 60)= result 1 result 1 + (Day * 60 * 60 * 24)= result 2 result 2 + (Month * 60 * 60 * 24 * 32) =result 3 result 3 + (Year * 60 * 60 * 24 * 32 * 13) =result 4 For the year write only the last two digits, for example 2014 must be 14 result 4 /65536= clock h without decimals If there are problems during calculation, please download the spreadsheet automatically from www.motive.it
38	R/W	magnetization	%	70	120	
39	R/W	T_R_fault_stop		0	1	0=OFF, 1=ON; When this function is ON, it switches off the motor if: -The T/R radio communication between keypad and NEO is missing for more than 5 seconds; -The modbus communication (Variable 40=2) loses the signal from serial port RS485;
40	R/W	modbus communication		0	2	0=OFF = programming and operation only from keypad 1=ON+KEY = programming from modbus and operation from keypad (External remote wired control/speed signal are included) 2=ON = programming and operation only from modubs
41	R/W	baud rate	bit/s	0	3	0=4800 1=9600 (default) 2=14400 3=19200
42						
43						
44	R/W	start[0]	minuti	0	1439	to calculate the value: hours*60+minutes (if there are problems during calculation, please download the spreadsheet automatically from www.motive.it)
45	R/W	stop[0]	minuti	0	1439	to calculate the value: hours*60+minutes (if there are problems during calculation, please download the spreadsheet automatically from www.motive.it)
46	R/W	start[1]	minuti	0	1439	to calculate the value: hours*60+minutes (if there are problems during calculation, please download the spreadsheet automatically from www.motive.it)
47	R/W	stop[1]	minuti	0	1439	to calculate the value: hours*60+minutes (if there are problems during calculation, please download the spreadsheet automatically from www.motive.it)
48	R/W	start[2]	minuti	0	1439	to calculate the value: hours*60+minutes (if there are problems during calculation, please download the spreadsheet automatically from www.motive.it)
49	R/W	stop[2]	minuti	0	1439	to calculate the value: hours*60+minutes (if there are problems during calculation, please download the spreadsheet automatically from www.motive.it)



50	R/W	start[3]	minuti	0	1439	to calculate the value: hours*60+minutes (if there are problems during calculation, please download the spreadsheet automatically from www.motive.it)
51	R/W	stop[3]	minuti	0	1439	to calculate the value: hours*60+minutes (if there are problems during calculation, please download the spreadsheet automatically from www.motive.it)
52	R/W	start[4]	minuti	0	1439	to calculate the value: hours*60+minutes (if there are problems during calculation, please download the spreadsheet automatically from www.motive.it)
53	R/W	stop[4]	minuti	0	1439	to calculate the value: hours*60+minutes (if there are problems during calculation, please download the spreadsheet automatically from www.motive.it)
54	R/W	enable starts timer		0	1	0=OFF, 1=ON
55	R/W	save parameters		0	541	to save the parameter, write 1 and next 541 (wait until it returns to 0 to confirm receipt)
56	R/W	reset factory data		0	541	to reset the factory data write 1 (Standard) or 2 (Ventilation) or 3 (Air Compressor) or 4 (HP pumps), and then 541 (wait until it returns to 0 to confirm receipt)
57	R/W	sensor minimum value	mA*10	0	100	
58	R/W	sensor maximum value	mA*10	100	300	
59	R/W	pressure range	bar*1000 (Ventilation) bar*100 (Air Compressor) bar*10 (HP pump)	69	16000	
60	R/W	pressure reference	bar*1000 (Ventilation) bar*100 (Air Compressor) bar*10 (HP pump)	69	Par.103	
61	R/W	pressure hysteresis	bar*1000 (Ventilation) bar*100 (Air Compressor) bar*10 (HP pump)	1	200	
62	R/W	delay time to stop when pressure is reached	seconds	1	99	
63	R/W	alarm saved		0	6539	it shows the last alarm saved, or the alarm corresponding to the number written
64	R	alarm type		1	29	type of last alarm recorded
65	R	time intervention alarm h	seconds*0x10000	0	0xffff	
66	R	time intervention alarm l	seconds	0	0xffff	
67	R	voltage during alarm intervention [V12]	V	-	-	
68	R	voltage during alarm intervention [V13]	V	-	-	
69	R	voltage during alarm intervention [V23]	V	-	-	
70	R	current during alarm intervention [I1]	A*10	-	-	
71	R	current during alarm intervention [I2]	A*10	-	-	
72	R	current during alarm intervention [I3]	A*10	-	-	
73	R	power during alarm intervention	W	-	-	
74	R	voltage capacitors during alarm intervention	Vdc	-	-	
75	R	frequency during alarm intervention	Hz	-	-	
76	R	power factor cosφ during alarm intervention	*100	-	-	
77	R	rpm during alarm intervention	rpm	-	-	
78	R	IGBT temperature during alarm intervention	°C	-	-	
79	R/W	pre-heating temperature	°C	0	50	
80	R	momentary value rpm/bar	rpm (speed) bar*1000 (Ventilation) bar*100 (Air Compressor) bar*10 (HP pump)	-	-	average value, measured in about 0,5 seconds
81	R	power	W	-	-	average value, measured in about 0,5 seconds
82	R	current	A*10	-	-	average value, measured in about 0,5 seconds
83	R	voltage	V	-	-	average value, measured in about 0,5 seconds
84	R	IGBT temperature	°C	-	-	average value, measured in about 0,5 seconds
85	R	power factor cosφ	*100	-	-	average value, measured in about 0,5 seconds



86	R	actual turn direction		0	2	0=OFF 1=direction 1 2=direction 2
87	R	frequenza_Hz	Hz*10	-	-	
88	R	stato_abilitazione		0	1	0=OFF, 1=ON
89	R	current speed/pressure reference	rpm (speed) bar*1000 (Ventilation) bar*100 (Air Compressor) bar*10 (HP pump)	-	-	reference value from keypad potentiometer or AN2 potentiometer or AN1 signal. (it depends on control mode 29 and machine code mode 56).
90	R	relay MOTOR ON status		0	1	0=OFF, 1=ON
91	R	relay ALARM status		0	1	0=OFF, 1=ON
92	R	relay FAN status		0	1	0=OFF, 1=ON
93	R	diagnostic inverter				16 bit register with all status bits (download the table chart from www.motive.it)
94	R	communication events		0	65535	
95	R/W	error counter CRC		0	0xffff	
96	R/W	error counter exception		0	0xffff	
97	R/W	counter messages received		0	0xffff	
98	R/W	counter messages received without any reply		0	0xffff	
99	R/W	counter messages NAK		0	0xffff	
100	R/W	counter messages with slave occupied		0	0xffff	
101	R/W	counter messages over-run		0	0xffff	
102						
103	R/W	maximum pressure limit	bar*1000 (Ventilation) bar*100 (Air Compressor) bar*10 (HP pump)	10	16000	the value range depends on the inverter type
104						
105	R/W	modbus command rotation		0	2	0=OFF 1=ON Direction 1 2=ON Direction 2
106						
107						
108						
109						
110						
111						

***Register table chart 22 - machine code for RS485 serial communication in group:

		N° inverters quantity							
		1	2	3	4	5	6	7	8
N° inverter	1	0	1	2	3	4	5	6	7
	2		8	9	10	11	12	13	14
	3			15	16	17	18	19	20
	4				21	22	23	24	25
	5					26	27	28	29
	6						30	31	32
	7							33	34
	8								35

8. WARNINGS AND RISKS



These instructions must be read and strictly adhered to by who is doing the final installation and by the user, and they must also be made available to all the personnel that sees to the installation, calibration and maintenance of the device.

Qualification of personnel

The installation, commissioning and maintenance of the device must be carried out only by technically qualified personnel who is aware of the risks that the use of this device involves.

Dangers from non-compliance with safety regulations

Failure to comply with safety requirements, beyond endangering people and damaging the equipment, will void all warranty. The consequences of non-observance of safety requirements can be

- Activation failure of some system functions.
- Danger to people resulting from electrical and mechanical events.

Safety requirements for the user

All the accident prevention regulations must be implemented and complied with. The keypad must be in a position from which the functioning of the system is visible.

Safety requirements for assembly and inspection

The customer must make sure that the assembly, inspection and maintenance operations are carried out by authorized and qualified personnel who has carefully read these instructions. Work on the equipment and machinery must be performed on a non-operating machine.

Spare parts

The original parts and the accessories authorized by the manufacturer are an integral part of the safety of the equipment and of the machines. The use of components or accessories that are not original may compromise safety and will void the warranty.

LABELS have been affixed on the boards, on the microprocessors, that are used to trace the inverter model and the production serial number + production date code (Month/Year). Removing this label and/or deleting the writing on them will render the warranty of the inverter or keypad null and void.

Loads with high inertia

The faster the motor slows down, the more the engine is operating under regenerative conditions and returns energy to the inverter. The voltage on the intermediate circuit of the drive can rise to a value beyond which the excess energy must be transferred to an external braking system. The external braking resistances are designed to absorb the energy in excess and to convert it into heat that is dissipated into the environment. The use of external braking resistances (terminals BR+ and BR-) allows for work cycles characterized by long or hard braking, or by very frequent braking. CAUTION: use additional external braking resistors with a value of 300 ohm $\pm 10\%$ (NEO-WiFi-3); 110 ohm $\pm 10\%$ (NEO-WiFi-11 / NEO-WiFi-22) and power suitable for the application, in the event of braking of motors with loads with high inertia

Before connecting the wires of the external braking resistances to the BR + and BR- terminals, disconnect from the same terminals the wires of the internal resistances and isolate them.

NEO-WiFi-3 - NEO-WiFi-4 - NEO-WiFi-5.5

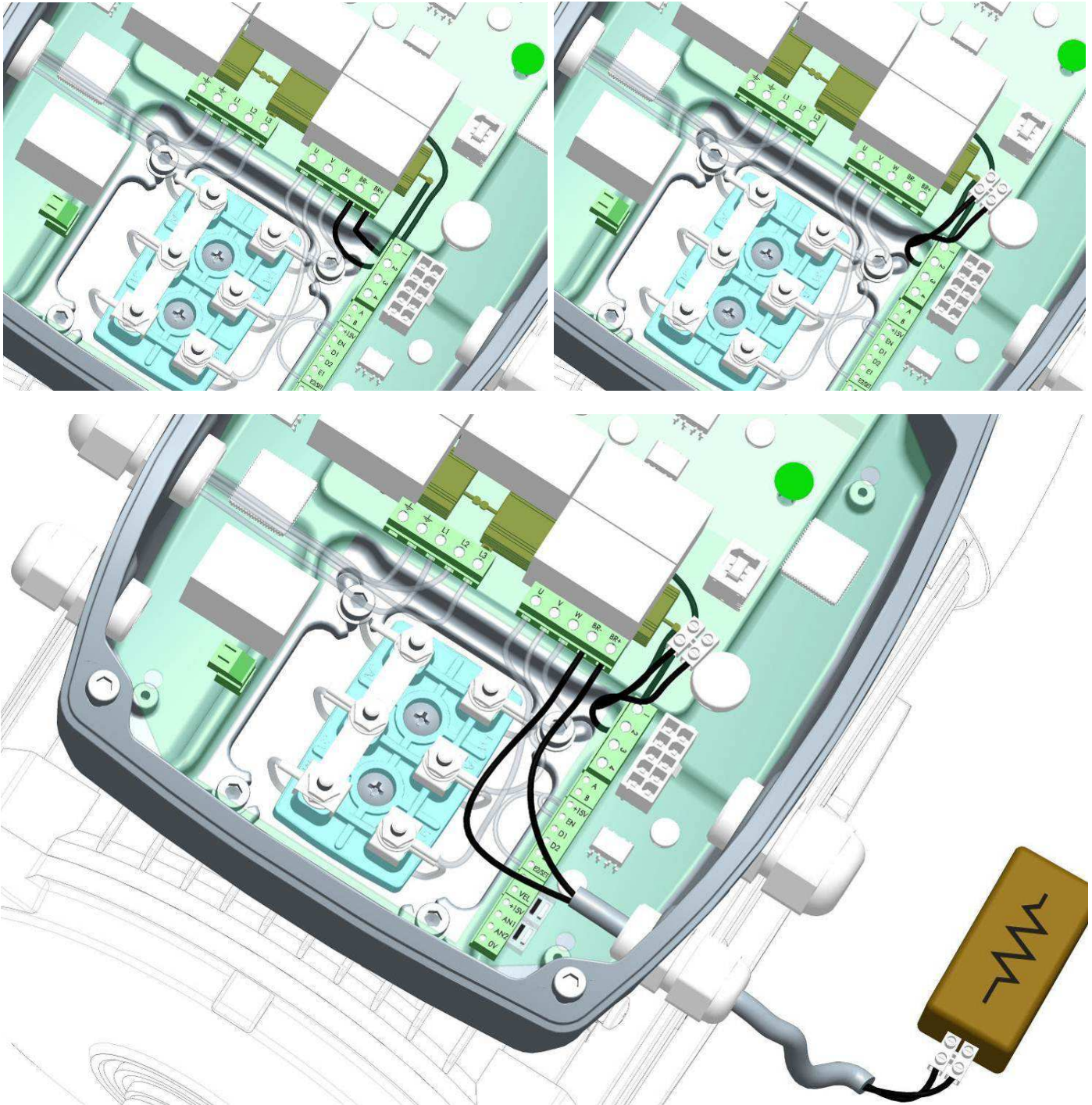

NEO-WiFi-11 - NEO-WiFi-22

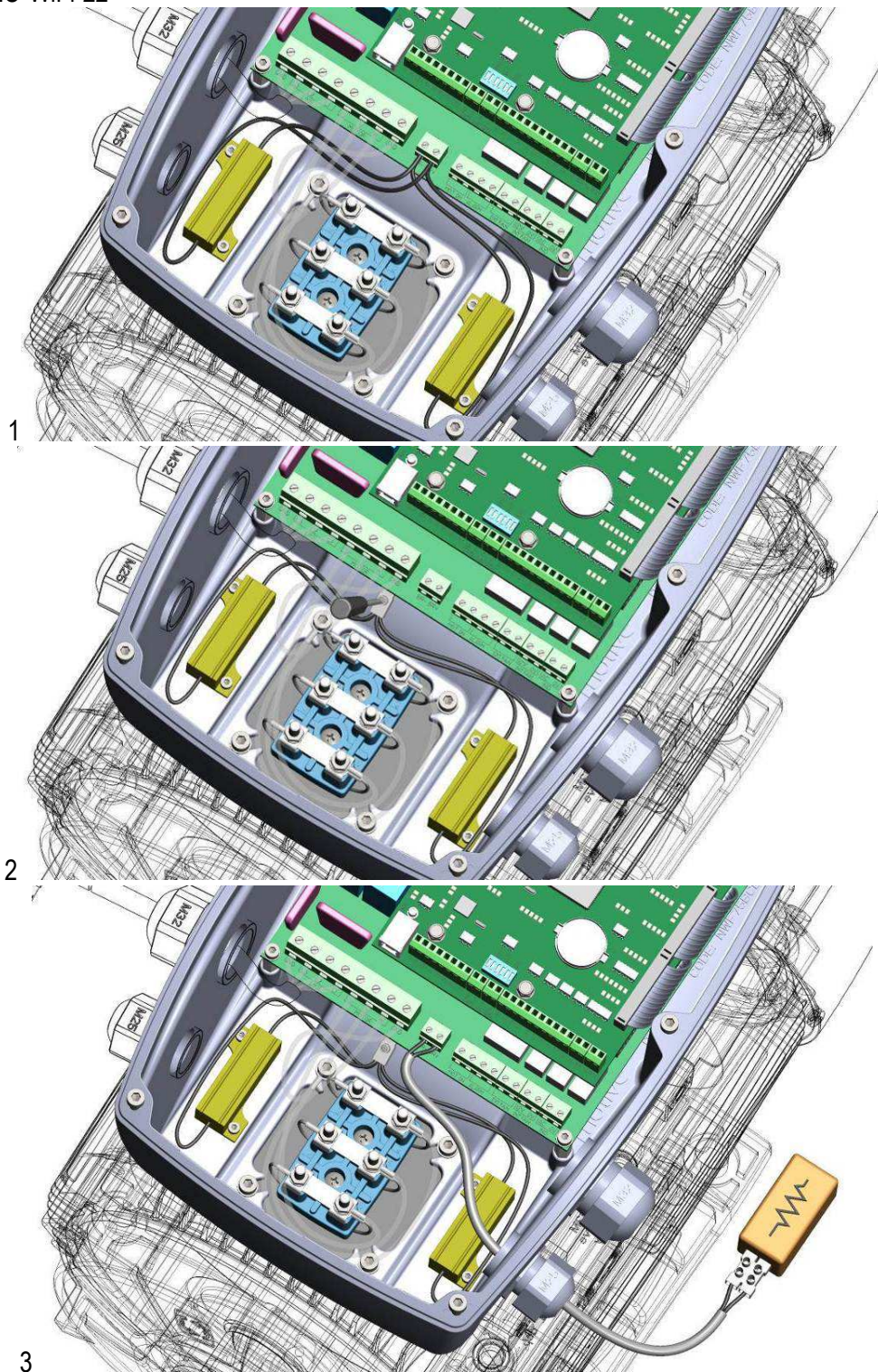

Caution! The instructions in this manual do not replace, but supplement the current law provisions on safety standards.

NEODYMIUM magnets

Warning

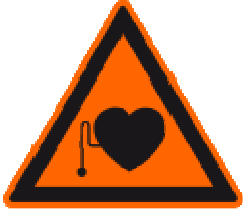

Pacemaker

Magnets could affect the functioning of pacemakers and implanted heart defibrillators.

- A pacemaker could switch into test mode and cause illness.
 - A heart defibrillator may stop working.
- If you wear these devices keep sufficient distance to magnets.
 - Warn others who wear these devices from getting too close to magnets.

Caution



Magnetic field

Magnets produce a far-reaching, strong magnetic field. They could damage TVs and laptops, computer hard drives, credit and ATM cards, data storage media, mechanical watches, hearing aids and speakers.

- Keep magnets away from devices and objects that could be damaged by strong magnetic fields.



It's forbidden to wash with water high pressure

Declaration of conformity

Motive srl based in Castenedolo (BS) – Italy

declares, under its exclusive responsibility, that its range of “NEO-WiFi” inverters and motor-inverters

is constructed in accordance with the following international regulations (latest edition)

- **EN 60034-1.** Rotating electrical machines: rating and performance
- **EN IEC 60034-5.** Rotating machines: definition of degrees of protection
- **EN 60034-30.** Rotating electrical machines: efficiency classes of single-speed, three-phase, cage-induction motors
- **EN 55014-2.** Electromagnetic compatibility. Requirements for household appliances, electric tools and similar apparatus. Part 2: Immunity
- **EN 61000-3-2.** Limits for harmonic current emissions (equipment input current ≤ 16 A per phase).
- **EN 61000-3-3.** Limitation of voltage fluctuations and flicker in low-voltage supply systems, for equipment with rated current ≤ 16 A
- **EN 61000-3-12.** Limits for harmonic currents produced by equipment connected to public low-voltage systems with rated input current greater than 16 A and ≤ 75 A per phase
- **EN 61000-6-3.** Electromagnetic compatibility (EMC): Part 6-3: Generic standards - Emission standard for residential, commercial and light-industrial environments
- **EN 61000-6-4.** Electromagnetic compatibility (EMC): Part 6-4: Generic standards - Emission standard for industrial environments
- **EN 50178.** Electronic equipment for use in power installations
- **ETSI 301 489-3.** Electromagnetic compatibility standard for radio equipment. Part 3: Specific conditions for Short-Range Devices (SRD) operating on frequencies between 9 kHz and 40 GHz

	NEO-WiFi-3 NEO-WiFi-4 NEO-WiFi-5.5 Cat. C1	NEO-WiFi-11 NEO-WiFi-22 Cat. C2
EMC for DOMESTIC, COMMERCIAL AND LIGHT INDUSTRIAL ENVIRONMENT	YES	Optional
EMC for INDUSTRIAL ENVIRONMENT	YES	YES

as required by the Directives

- Low Voltage Directive (LVD) **2014/35/EEC**
- Electromagnetic Compatibility Directive (EMC) **2014/30/EEC**
- Ecodesign Directive for energy related products (ErP) **2019/1781/EEC**

The Legal Representative

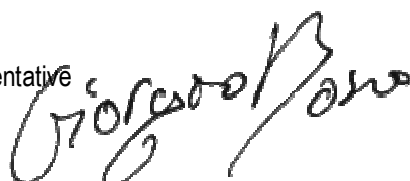

Declaration of conformity UKCA

Motive srl based in Castenedolo (BS) – Italy

declares, under its exclusive responsibility, that its range of “**NEO-WiFi**” inverters and motor-inverters

is constructed in accordance with the following international regulations (latest edition)

- **BS EN 60034-1.** Rotating electrical machines: rating and performance
- **BS EN IEC 60034-5.** Rotating machines: definition of degrees of protection
- **BS EN 60034-30.** Rotating electrical machines: efficiency classes of single-speed, three-phase, cage-induction motors
- **BS EN 55014-2.** Electromagnetic compatibility. Requirements for household appliances, electric tools and similar apparatus. Part 2: Immunity
- **BS EN 61000-3-2.** Limits for harmonic current emissions (equipment input current ≤ 16 A per phase)
- **BS EN 61000-3-3.** Limitation of voltage fluctuations and flicker in low-voltage supply systems, for equipment with rated current ≤ 16 A
- **BS EN 61000-3-12.** Limits for harmonic currents produced by equipment connected to public low-voltage systems with rated input current greater than 16 A and ≤ 75 A per phase
- **BS EN 61000-6-3.** Electromagnetic compatibility (EMC): Part 6-3: Generic standards - Emission standard for residential, commercial and light-industrial environments
- **BS EN 61000-6-4.** Electromagnetic compatibility (EMC): Part 6-4: Generic standards - Emission standard for industrial environments
- **BS EN 50178.** Electronic equipment for use in power installations
- **ETSI 301 489-3.** Electromagnetic compatibility standard for radio equipment. Part 3: Specific conditions for Short-Range Devices (SRD) operating on frequencies between 9 kHz and 40 GHz

	NEO-WiFi-3 NEO-WiFi-4 NEO-WiFi-5.5 Cat. C1	NEO-WiFi-11 NEO-WiFi-22 Cat. C2
EMC for DOMESTIC, COMMERCIAL AND LIGHT INDUSTRIAL ENVIRONMENT	YES	Optional
EMC for INDUSTRIAL ENVIRONMENT	YES	YES

as required by the Directives

Low Voltage (LVD) **2014/35/EEC**,
UK Electrical Equipment (Safety) **Regulations 2016**

EMC Electromagnetic Compatibility (EMC) **2014/30/EEC**
UK EMC Electromagnetic Compatibility **Regulations 2016**

Eco-design Directive for Energy-related Products (ErP) **2019/1781/EEC**
UK The Ecodesign for Energy-Related Products and Energy Information (Amendment) (EU Exit) **Regulations 2019**

The Legal Representative

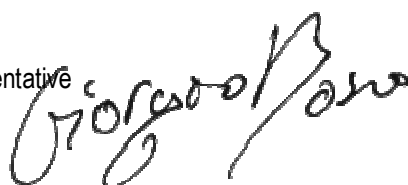

ЕВРАЗИЙСКИЙ ЭКОНОМИЧЕСКИЙ СОЮЗ ДЕКЛАРАЦИЯ О СООТВЕТСТВИИ



Заявитель Общество с ограниченной ответственностью "ПРИВОД ГРАНД РЕДУКТОР"

Место нахождения и адрес места осуществления деятельности: Российская Федерация, Смоленская область, 214004, город Смоленск, улица Багратиона, дом 4, офис 46, основной государственный регистрационный номер: 1166733076608, номер телефона: +79203158381, адрес электронной почты: privodgrand@gmail.com

в лице Директора Шелеста Александра Иосифовича

заявляет, что Оборудование электротехническое промышленного назначения: Частотные преобразователи (инверторы), модели: NEO-WiFi, NEO-PUMP, NEO-SOLAR, NEO-OLEO, NEO-COMP, NEO-VENT, NANO

изготовитель «Motive Srl». Место нахождения и адрес места осуществления деятельности по изготовлению продукции: Via Le Ghiselle, 20, 25014 Castenedolo BS, Италия.

Продукция изготовлена в соответствии с Директивами 2014/30/EU "О электромагнитной совместимости", 2014/35/EU "По низковольтному оборудованию и системам".

Код ТН ВЭД ЕАЭС 8504409000. Серийный выпуск

соответствует требованиям

Технический регламент Таможенного союза «О безопасности низковольтного оборудования» (ТР ТС 004/2011), Технический регламент Таможенного союза «Электромагнитная совместимость технических средств» (ТР ТС 020/2011)

Декларация о соответствии принята на основании

Протокола испытаний № 32320.301120 от 30.11.2020 года, выданного Испытательной лабораторией «ОНИКС», аттестат аккредитации ОНПС RU.04ОПС0.ИЛ02.

Схема декларирования 1д

Дополнительная информация

ГОСТ 12.2.007.0-75 «Система стандартов безопасности труда. Изделия электротехнические. Общие требования безопасности»; ГОСТ 30804.6.2-2013 «Совместимость технических средств электромагнитная. Устойчивость к электромагнитным помехам технических средств, применяемых в промышленных зонах. Требования и методы испытаний», (раздел 8); ГОСТ 30804.6.4-2013 «Совместимость технических средств электромагнитная. Электромагнитные помехи от технических средств, применяемых в промышленных зонах. Нормы и методы испытаний», (раздел 7). Условия хранения продукции в соответствии с ГОСТ 15150-69 "Машины, приборы и другие технические изделия. Исполнения для различных климатических районов. Категории, условия эксплуатации, хранения и транспортирования в части воздействия климатических факторов внешней среды", срок хранения (службы, годности) указан в прилагаемой к продукции товаросопроводительной и/или эксплуатационной документации.

Декларация о соответствии действительна с даты регистрации по 06.12.2025 включительно

(подпись)



Шелест Александр Иосифович

(Ф.И.О. заявителя)

Регистрационный номер декларации о соответствии: ЕАЭС N RU Д-ИТ.НВ54.В.04614/20

Дата регистрации декларации о соответствии: 07.12.2020

ALL THE DATA WAS COMPILED AND CHECKED WITH THE UTMOST CARE.
WE DO NOT HOWEVER ASSUME ANY RESPONSIBILITY FOR ANY ERRORS OR OMISSIONS.
MOTIVE srl MAY AT ITS SOLE DISCRETION CHANGE AT ANY TIME THE CHARACTERISTICS OF THE PRODUCTS SOLD.



FOR ATEX VARIABLE SPEED DRIVES, THE “ATEX ADDENDUM” FILE INTEGRATES THIS MANUAL



Motive srl
www.motive.it
motive@e-motive.it
Tel: +39 030 2677087
Fax: +39 030 2677125

